

---

**LIMITED WARRANTY • 1**  
**LIMITED WARRANTY - MAGNUM CHASSIS • 5**  
**WARRANTY INFORMATION FILE • 8**

---

**SAFARI MOTORHOME LIMITED WARRANTY**

**LIMITED  
WARRANTY  
- 2002 Sahara**

**What the Period of Coverage Is:**

If you use your Safari motorhome only for recreational travel and family camping purposes, the Limited Warranty provided by Safari ("Warrantor") covers your new motorhome when sold by an authorized dealer, for twelve (12) months from the original retail purchase date or the first 24,000 miles of use, whichever occurs first. However, the Limited Warranty provided by Warrantor covers the steel or aluminum frame structure of the sidewalls (excluding slide outs), roof, and rear and front walls for sixty (60) months from the original retail purchase date or the first 50,000 miles of use, whichever occurs first.

If you use your motorhome for any rental, commercial or business purposes whatsoever, the Limited Warranty provided by Warrantor covers your new motorhome when sold by an authorized dealer for ninety (90) days from the original retail purchase date or the first 24,000 miles of use, whichever occurs first. In addition, the Limited Warranty provided by Warrantor covers the steel or aluminum frame structure of the sidewalls (excluding slide outs), roof, and rear and front walls for twelve (12) months from the original retail purchase date or the first 24,000 miles of use, whichever occurs first. A conclusive presumption that your motorhome has been used for commercial and/or business purposes arises if you have filed a federal or state tax form claiming any business tax benefit related to your ownership of the motorhome.

The above Limited Warranty coverage applies to all owners, including subsequent owners, of the motorhome. However, a subsequent owner must submit a warranty transfer form by filing the form through an authorized Safari dealer. A subsequent owner's warranty coverage period is the remaining balance of the warranty coverage period the prior owner was entitled to under this Limited Warranty. Warranty transfer forms can be obtained by contacting the Consumer Affairs Department. There is no charge for the transfer.

**Limitations of Implied Warranties**

**ANY IMPLIED WARRANTIES ARISING BY WAY OF STATE LAW, INCLUDING ANY IMPLIED WARRANTY OF MERCHANTABILITY AND ANY IMPLIED WARRANTY OF FITNESS FOR A PARTICULAR PURPOSE, ARE LIMITED IN DURATION TO THE TERM OF THIS LIMITED WARRANTY AND ARE LIMITED IN SCOPE OF COVERAGE TO THOSE PORTIONS OF THE MOTORHOME COVERED BY THIS LIMITED WARRANTY.** There is no warranty of any nature made by Warrantor beyond that contained in this Limited Warranty. No person has authority to enlarge, amend or modify this Limited Warranty. The dealer is not the Warrantor's agent but is an independent entity. Warrantor is not responsible for any undertaking, representation or warranty made by any dealer or other person beyond those expressly set forth in this Limited Warranty. Some states do not allow limitations on how long an implied warranty lasts, so the above limitation may not apply to you.

---

**What the Warranty Covers**

Warrantor's Limited Warranty covers defects in the manufacture of your motorhome and defects in materials used to manufacture your motorhome. Also see the section "What the Warranty Does Not Cover" set out below.

---

**What We Will Do to Correct Problems**

Warrantor will repair and/or replace, at its option, any covered defect if: (1) you notify Warrantor or one of its authorized servicing dealers of the defect within the warranty coverage period and within five (5) days of discovering the defect; and (2) you deliver your Motorhome to Warrantor or Warrantor's authorized servicing dealer at your cost and expense. It is reasonable to expect some service items to occur during the warranty period.

Warrantor may use new and/or remanufactured parts and/or components of substantially equal quality to complete any repair.

Defects and/or damage to interior and exterior surfaces, trim, upholstery and other appearance items may occur at the factory during manufacture, during delivery of the motorhome to the selling dealer or on the selling dealer's lot. Normally, any such defect or damage is detected and corrected at the factory or by the selling dealer during the inspection process performed by the Warrantor and the selling dealer. If, however, you discover any such defect or damage when you take delivery of the motorhome, you must notify your dealer or Warrantor within five days of the date of purchase to have repairs performed to the defect at no cost to you as provided by this Limited Warranty.

If two or more unsuccessful repair attempts have been made to correct any covered defect that you believe substantially impairs the value, use or safety of your motorhome, you must, to the extent permitted by law, notify Warrantor directly in writing of the failure to successfully repair the defect so that Warrantor can become directly involved in performing a successful repair to the identified defect.

## **How to Get Service**

The Warranty Registration form must be returned to Warrantor promptly upon purchase to assure proper part replacement and repair of your motorhome. Failure to return the warranty registration form will not affect your rights under the Limited Warranty so long as you can furnish proof of purchase. For warranty service simply contact one of Warrantor's authorized service centers for an appointment, then deliver your motorhome (at your expense) to the service center. If you need assistance in locating an authorized warranty service facility, contact **Warrantor's Warranty Department (1-800-344-6332)**. The mailing address is:

**Warrantor's Warranty Department  
91320 Coburg Industrial Way  
Coburg, Oregon 97408**

In the event the motorhome is inoperative due to malfunction of a warranted part, Warrantor will pay the cost of having the motorhome towed to the nearest authorized repair facility provided you notify Warrantor prior to incurring the towing charges to receive directions to the nearest repair facility.

Because Warrantor does not control the scheduling of service work by its authorized servicing dealers, you may encounter some delay in scheduling and/or in the completion of the repairs.

This Limited Warranty does not cover: any motorhome sold or registered outside of the United States or Canada; items which are added or changed after the motorhome leaves Warrantor's possession; items that are working as designed but which you are unhappy with because of the design; normal wear and usage, such as fading or discoloration of fabrics, or the effects of condensation inside the motorhome; defacing, scratching, dents and chips on any surface or fabric of the motorhome, not caused by Warrantor; routine maintenance, including by way of example wheel alignments; the automotive chassis and power train, including, by way of example the engine, drivetrain, steering and handling, braking, wheel balance, muffler, tires, tubes, batteries and gauges; appliances and components covered by their own manufacturer's warranty including, by way of example the microwave, refrigerator, ice maker, stove, oven, generator, roof air conditioners, hydraulic jacks, VCR, television(s), water heater, furnace, stereo, radio, compact disc player, washer, dryer, inverter and cellular phone; or flaking, peeling and chips or other defects or damage in or to the exterior or finish caused by rocks or other road hazards, the environment including airborne pollutants, salt, tree sap and hail.

## **What the Warranty Does Not Cover**

**Events Discharging Warrantor from Obligation Under Warranty**

Misuse or neglect, accidents, unauthorized alteration, failure to provide reasonable and necessary maintenance (See Owner's Manual), damage caused by off road use, collision, fire, theft, vandalism, explosions, overloading, and odometer tampering shall discharge Warrantor from any express or implied warranty obligation to repair any resulting defect.

---

**Disclaimer of Consequential & Incidental Damages**

**THE ORIGINAL PURCHASER OF THE MOTORHOME AND ANY PERSON TO WHOM THE MOTORHOME IS TRANSFERRED, AND ANY PERSON WHO IS AN INTENDED OR UNINTENDED USER OR BENEFICIARY OF THE MOTORHOME , SHALL NOT BE ENTITLED TO RECOVER FROM WARRANTOR ANY CONSEQUENTIAL OR INCIDENTAL DAMAGES RESULTING FROM ANY DEFECT IN THE MOTORHOME. THE EXCLUSION OF CONSEQUENTIAL AND INCIDENTAL DAMAGES SHALL BE DEEMED INDEPENDENT OF, AND SHALL SURVIVE, ANY FAILURE OF THE ESSENTIAL PURPOSE OF ANY LIMITED REMEDY.** Some states do not allow the exclusion or limitation of consequential or incidental damages, so the above exclusions may not apply to you.

---

**Legal Remedies**

**ANY ACTION TO ENFORCE THIS EXPRESS OR ANY IMPLIED WARRANTY SHALL NOT BE COMMENCED MORE THAN ONE (1) YEAR AFTER THE EXPIRATION OF THIS WARRANTY.** Some states do not allow the reduction in the statute of limitations, so the above reduction may not apply to you.

**THIS WARRANTY GIVES YOU SPECIFIC LEGAL RIGHTS, AND YOU MAY ALSO HAVE OTHER RIGHTS, WHICH VARY FROM STATE TO STATE.**

00089

---

**MAGNUM CHASSIS LIMITED WARRANTY**

**LIMITED  
WARRANTY  
- MAGNUM  
CHASSIS**

**What the Period of Coverage Is:**

If you use the Magnum Chassis that your motorhome is mounted upon for only recreational travel and family camping purposes, the Limited Warranty provided by Magnum ("Warrantor") covers your Magnum Chassis for twenty-four (24) months from the original retail purchase date or the first 24,000 miles of use, whichever occurs first.

If you use the Magnum Chassis that your motorhome is mounted upon for any rental, commercial or business purposes whatsoever, the Limited Warranty provided by Warrantor covers your new Magnum Chassis for Ninety (90) days from the original retail purchase date of the motorhome or the first 24,000 miles of use, whichever occurs first. A conclusive presumption that the Magnum Chassis has been used for commercial and/or business purposes arises if you have filed a federal or state tax form claiming any business tax benefit related to your ownership of the motorhome.

---

**ANY IMPLIED WARRANTIES ARISING BY WAY OF STATE LAW, INCLUDING ANY IMPLIED WARRANTY OF MERCHANTABILITY AND ANY IMPLIED WARRANTY OF FITNESS FOR A PARTICULAR PURPOSE, ARE LIMITED IN DURATION TO THE TERM OF THIS LIMITED WARRANTY AND ARE LIMITED IN SCOPE OF COVERAGE TO THOSE PORTIONS OF THE MAGNUM CHASSIS COVERED BY THIS LIMITED WARRANTY.** There is no warranty of any nature made by Warrantor beyond that contained in this Limited Warranty. No person has authority to enlarge, amend or modify this Limited Warranty. Any dealer selling a motorhome assembled upon a Magnum Chassis is not the Warrantor's agent but is an independent entity. Warrantor is not responsible for any undertaking, representation or warranty made by any dealer or other person beyond those expressly set forth in this Limited Warranty. Some states do not allow limitations on how long an implied warranty lasts, so the above limitation may not apply to you.

***Limitations of  
Implied Warranties***

---

Warrantor's Limited Warranty covers defects in the manufacture of the Magnum Chassis (as defined herein) and defects in materials used to manufacture the Magnum Chassis. The term "Magnum Chassis" as used herein means only the frame; frame cross members; steering axle, including the axle king pins and bushings; hubs and bearings; brake calipers; rotors, brake backing plates and related parts of the axle; tie rods; drag links; drive shafts, including the U-joints; carrier bearings; and, the axle housing and its internal parts. Also see the section "What the Warranty Does Not Cover" set out below.

***What the Warranty  
Covers***

**What We Will Do to Correct Problems**

Warrantor will repair and/or replace, at its option, any covered defect if: (1) you notify Warrantor or one of its authorized servicing dealers of the defect within the warranty coverage period and within five (5) days of discovering any such defect; and (2) you deliver the Magnum Chassis to Warrantor or Warrantor's authorized servicing dealer at your cost and expense. It is reasonable to expect some service items to occur during the warranty period.

Warrantor may use new and/or remanufactured parts and/or components of substantially equal quality to complete any repairs.

Defect and/or damage to the Magnum Chassis may occur during manufacture at the factory, during delivery of the motorhome to the selling dealer or on the selling dealer's lot. Normally, any factory defect or damage is detected and corrected at the factory or by the selling dealer during the inspection process performed by the Warrantor and the selling dealer. If, however, you discover any such defect or damage when you take delivery of the Magnum Chassis, you must notify your dealer or Warrantor within five days of the date of purchase to have repairs performed to any such defect at no cost to you as provided by this Limited Warranty.

If two or more unsuccessful repair attempts have been made to correct any covered defect that you believe substantially impairs the value, use or safety of your motorhome, you must, to the extent permitted by law, notify Warrantor directly in writing of the failure to successfully repair the defect so that Warrantor can become directly involved in performing a successful repair to the identified defect.

---

**How to Get Service**

For warranty service simply contact one of Warrantor's authorized service centers for an appointment, then deliver your Magnum Chassis (at your expense) to the service center. If you need assistance in locating an authorized warranty service facility, contact **Warrantor's Warranty Department (1-800-344-6332)**. The mailing address is:

**Warrantor's Warranty Department  
93120 Coburg Industrial Way  
Coburg, Oregon 97408**

In the event the Magnum Chassis is inoperative due to malfunction of a warranted part, Warrantor shall pay the cost of having the Magnum Chassis that the motorhome is mounted upon towed to the nearest authorized repair facility provided you notify Warrantor prior to incurring the towing charges to receive directions to the nearest repair facility.

Because Warrantor does not control the scheduling of service work by its authorized servicing dealers, you may encounter some delay in scheduling and/or in the completion of the repairs.

---

This Limited Warranty does not cover: modifications and alterations to the Magnum Chassis by others; the motorhome that is mounted upon the Magnum Chassis, including by way of example the motorhome manufacturer's design, manufacture, assembly and/or installation of the side walls, roof, windows, flooring, electrical system, plumbing system, LP-Gas system, appliances and slide-outs; items that are working as designed but which you are unhappy with because of the design; normal wear and usage; routine maintenance including by way of example wheel alignments; component parts covered by their own manufacturer's warranty, including by way of example the engine, transmission, tires, tubes, batteries, exhaust system and the emission control systems; and, flaking, peeling rusting and chips or other defects or damage in or to the frame and frame cross members caused by rocks or other road hazards and the environment including airborne pollutants and salt.

***What the Warranty Does Not Cover***

---

Misuse or neglect, accidents, unauthorized alteration, failure to provide reasonable and necessary maintenance (See Owner's Manual), damage caused by off road use, collision, fire, theft, vandalism, explosions, overloading, and odometer tampering shall discharge Warrantor from any express or implied warranty obligation to repair any resulting defect.

***Events Discharging Warrantor from Obligation Under Warranty***

---

**THE ORIGINAL RETAIL PURCHASER OF THE MAGNUM CHASSIS AND ANY PERSON TO WHOM THE MAGNUM CHASSIS IS TRANSFERRED, AND ANY PERSON WHO IS AN INTENDED OR UNINTENDED USER OR BENEFICIARY OF THE MAGNUM CHASSIS, SHALL NOT BE ENTITLED TO RECOVER FROM WARRANTOR ANY CONSEQUENTIAL OR INCIDENTAL DAMAGES RESULTING FROM ANY DEFECT IN THE MOTORHOME. THE EXCLUSION OF CONSEQUENTIAL AND INCIDENTAL DAMAGES SHALL BE DEEMED INDEPENDENT OF, AND SHALL SURVIVE, ANY FAILURE OF THE ESSENTIAL PURPOSE OF ANY LIMITED REMEDY.** Some states do not allow the exclusion or limitation of consequential or incidental damages, so the above exclusions may not apply to you.

***Disclaimer of Consequential & Incidental Damages***

---

**ANY ACTION TO ENFORCE THIS EXPRESS OR ANY IMPLIED WARRANTY SHALL NOT BE COMMENCED MORE THAN ONE (1) YEAR AFTER THE EXPIRATION OF THIS WARRANTY.** Some states do not allow the reduction in the statute of limitations, so the above reduction may not apply to you.

***Legal Remedies***

**THIS WARRANTY GIVES YOU SPECIFIC LEGAL RIGHTS, AND YOU MAY ALSO HAVE OTHER RIGHTS WHICH VARY FROM STATE TO STATE.**

**MAGNUM CHASSIS  
MONACO COACH CORPORATION  
91320 COBURG INDUSTRIAL WAY  
COBURG, OREGON 97408**

---

**WARRANTY  
INFORMATION  
FILE**

In addition to this Owner's Manual you will find a Warranty Information File in your unit. This file contains valuable documents about your motorhome's systems and equipment. Many of the component manufacturer's warranty registration cards can be found in the box. They will need to be filled out and mailed. Be sure you read and understand all the information in this file to help you safely operate, maintain and troubleshoot those items.

**WOOD FINISH**

Because no two trees look alike, authentic woods vary in color and character markings such as streaks, knots and grain patterns. Since the stains may attach differently to these grain patterns, some natural light and dark areas may result. The beauty lies in these natural variations of color and grain that give each cabinet its own individual charm.

The beauty of these products is protected with a furniture-quality exterior finish. After a period of time, there may be minimal changes in the finish color as it ages in its surrounding conditions. This is an inherent characteristic of this particular finish, and the natural aging process adds to the unique appearance of the cabinetry. Due to the minor differences in tone, it may not be possible to match the finish color of existing cabinets exactly when replacing doors or adding additional cabinets at a later date.

The foregoing is not a warning. See the Limited Warranty or call (877) 466-6226 for warranty information and limitations.



# SAHARA

SECTIONS

1

GENERAL INFORMATION

2

DRIVING & SAFETY

3

CARE & MAINTENANCE

4

APPLIANCES

5

EQUIPMENT

6

WATER SYSTEMS

7

LP-GAS SYSTEMS

8

ELECTRICAL SYSTEMS - HOUSE

9

ELECTRICAL SYSTEMS - CHASSIS

10

CHASSIS INFORMATION

## **SIGNS**

---



This sign indicates a **NOTE**.



This sign indicates a **WARNING** or a **CAUTION** with additional information attached.



This sign indicates **INSPECTION** is required.



This sign indicates **ASSEMBLY/INSTALLATION** or **DISASSEMBLY/REMOVAL** is necessary.



This sign indicates the specified part requires **OIL/LUBRICATION**.



This sign indicates a reference to the **Warranty INFORMATION FILE** located within the Warranty Information box inside the motorhome.

The information contained in this document is intended to reflect standard and optional equipment included in a typically equipped model at the time of delivery to the initial retail owner. Your actual unit may vary from this document as a result of optional equipment that is not generally offered on this model. In the case that you are not the initial retail owner of this unit, this document will not reflect modifications that may have been performed by previous owners.

Product information and specifications are shown herein as of the time of printing. Safari reserves the right to change product specifications, designs and standard equipment without notice and without incurring obligation.

©Copyright Monaco Coach Corporation. All rights reserved. The Sahara is a trademark of Monaco Coach. All other trademarks or registered trademarks are property of their respective holders. Brand name products of other companies mentioned in this manual are not endorsed by Monaco Coach Corporation.

# SAHARA

## SECTION 1 GENERAL INFORMATION

<b>INTRODUCTION</b>	<b>• 13</b>
<b>CUSTOMER RELATIONS</b>	<b>• 13</b>
<b>REPORTING SAFETY DEFECTS</b>	<b>• 14</b>
<b>TAKING DELIVERY</b>	<b>• 14</b>
<i>Safari Responsibilities</i>	<i>• 14</i>
<i>Dealer Responsibilities</i>	<i>• 14</i>
<i>Customer Responsibilities</i>	<i>• 15</i>
<b>SERVICE SUGGESTIONS</b>	<b>• 15</b>
<i>Prepare for the Appointment</i>	<i>• 15</i>
<i>Prepare a List</i>	<i>• 15</i>
<i>Be Reasonable With Your Requests</i>	<i>• 15</i>
<i>No Looking Over the Technician's Shoulder</i>	<i>• 16</i>
<i>Inspect the Work Properly</i>	<i>• 16</i>
<b>OWNER'S RECORD - SERIAL NUMBERS</b>	<b>• 17</b>
<b>OWNER'S RECORD - PERSONAL PROPERTY</b>	<b>• 18</b>
<b>OWNER'S RECORD - INSURANCE</b>	<b>• 19</b>
<b>GLOSSARY OF TERMS</b>	<b>• 20</b>
<b>VENDOR LIST</b>	<b>• 24</b>
<b>SURVEY</b>	<b>• 27</b>





## INTRODUCTION

This section contains warranty information and knowledge for the operation and care of the motorhome. Not all information may be applicable to your model of motorhome. More detailed information with **CAUTION** or **WARNING** instructions, other than what is found in this chapter, can be found in the manufacturer's owner manuals located in the owner information box.

In time you will develop a knack for spotting wonderful little roadside locations by turning off the main highway and exploring. There are many modern recreational vehicle parks (including state, county and federal parks) with good facilities where you can obtain hook-ups for electrical, water and sewage connections. Directories are published which describe these parks and the availability of services and hook-ups. On overnight or weekend trips, chances are you will probably not fill up the sewage holding tanks, deplete the water or LP-Gas supply, or run down the batteries which supply the living area with 12 Volt DC current. On longer trips, when you have stayed where sewer connections and utility hook-ups were not available, it will be necessary to occasionally empty the holding tanks and replenish the water and LP-Gas supply.

Many gas stations have installed sanitary dumping stations. Publications are available which list these dumping stations. When stopped for the night, the motorhome is built to be safely parked in any spot that is relatively level and where the ground is firm. Try to pick as level a parking spot as possible. Your facilities are with you and the motorhome is fully self-contained.

The safety alert symbols of **CAUTION** or **WARNING** are "Personal Safety Instructions." It is important to thoroughly read and understand these safety instructions where the symbols are displayed throughout the manual. Failure to comply with specific instructions may result in personal injury or death. Many instructions are required by National Safety Associations.

Only by ensuring your confidence and satisfaction with our products and services can we have continued success as a manufacturer of motorhomes. We believe a good relationship with our customers is just as important as improving the technical excellence of our products. Your authorized dealer is pleased to help you with instructions about your motorhome and to offer service when you need it. If problems remain after you have consulted your dealer you are invited to contact our Consumer Affairs Department. Please have all pertinent information (serial numbers, model number, etc.) when calling. We will work with the dealer and see that every attempt to resolve the matter is made.

## CUSTOMER RELATIONS

**Customer Service Department  
91320 Coburg Industrial Way  
Coburg, Oregon 97408  
877-466-6226**

## **REPORTING SAFETY DEFECTS**

If you believe that your motorhome has a defect which could cause a crash or could cause injury or death, you should immediately inform the National Highway Traffic Safety Administration (NHTSA) in addition to notifying Safari. If NHTSA receives similar complaints, it may open an investigation, and if it finds that a safety defect exists in a group of motorhomes, it may order a recall or remedy campaign. However, NHTSA cannot become involved in individual problems between you, your dealer or Safari. To contact NHTSA you may either call the Auto Safety Hot line toll-free at 1-800-424-9393 (or 1-202-366-0123 in the Washington D.C. area) or write to:

**NHTSA  
U.S. Department of Transportation  
400 Seventh Street  
Washington, DC 20590**

---

## **TAKING DELIVERY Safari Responsibilities**

Your motorhome has been manufactured to the highest quality and standards by factory trained personnel. Quality inspections are performed throughout the manufacturing process of your motorhome. The motorhome has been carefully and almost completely hand assembled in our factory. Prior to the motorhome arriving at the dealership, all systems have been carefully tested and inspected to ensure optimum performance. The necessary forms and required manuals have been placed in the motorhome at the time of shipment to the dealership.

---

## **Dealer Responsibilities**

The dealer must perform additional pre-delivery inspections and system checks, assist in the customer's understanding of the Limited Warranty and assist in completing any necessary forms. They must do a customer orientation to the motorhome, its systems, components and their operation.

The dealer should also ensure the customer receives a complete Owner's Packet with warranty cards and registrations for the motorhome and for separately warranted products, including detailed operating and maintenance instructions. The dealer is responsible for performing a review of the Limited Warranty provisions with the customer, while stressing the importance of mailing warranty cards and registrations to the manufacturers within the prescribed time limit to avoid loss of warranty coverage. They must assist the customer in completing these forms and locating serial numbers. They should request that the customer reads all warranty information when possible and explain any provision not clearly understood.

The dealer should instruct the customer on how to obtain local and out-of-town service on the motorhome and its various individual warranted components, whether the service is warrantable or out of warranty.

**Customer  
Responsibilities**

As a new motorhome owner you are responsible for regular and proper maintenance. This will help you prevent conditions arising from neglect that are not covered by your Safari Limited Warranty. Maintenance services should be performed in accordance with this Owner's Manual, and any other applicable manuals. As the owner, it is your responsibility and obligation to return the motorhome to an authorized dealer for repairs and service (See the Limited Warranty). Since the authorized dealer where you purchased your new motorhome is responsible for its proper servicing before delivery, and has an interest in your continued satisfaction, we recommend that Inspection, Warranty and Maintenance Services be performed by the dealership. We suggest that you take your new motorhome on a weekend shakedown before leaving on an extended trip.

---

**SERVICE  
SUGGESTIONS**

Know when to take your motorhome in for service. Give some thought to the appointment time. There are several things to consider when selecting a time for service. Location of the service center and the time of year can be a major issue. Monday and Friday are busy days for most dealers. Therefore, it makes sense to make a mid-week appointment whenever possible. Ask your dealer if additional time is needed for check in and completion of paperwork.

---

**Prepare for the  
Appointment**

If you're having warranty work done, be sure to have your warranty registration papers with you. All work to be performed may not be covered by the warranty; be sure to discuss additional charges with the service manager. Keep a maintenance log of your motorhome service history. This can often provide a clue to the current problem.

---

**Prepare a List**

Make a written list of specific repairs needed. It is important the service manager be aware of all previous work which has been done on your motorhome. For example: if the motorhome has been repaired due to an accident. While this may not seem important, it could have a significant effect on the dealer's diagnosis of a problem.

---

**Be Reasonable  
With Your  
Requests**

Don't leave a list of 20 items to be serviced and expect to have the motorhome back by 5:00 p.m. If you list a number of items, and must have your motorhome back by the end of the day, discuss the situation with the service manager and list items in order of priority. Some items may not be able to be repaired due to work loads or parts availability. Expect to make a second appointment for work not completed or for the long, drawn-out repair item.

***No Looking Over  
the Technician's  
Shoulder***

Please don't be offended when you are told you cannot watch the work being done. Many service area insurance requirements forbid the admission of customers into the service work area.

---

***Inspect the Work  
Properly***

Check out the service or repair job when you pick up your motorhome and notify the service manager of any dissatisfaction. If circumstances prevent returning for immediate corrective work, make an appointment as soon as possible.



**FOR YOUR OWN REFERENCE**

**OWNER'S RECORD - SERIAL NUMBERS**



**INFORMATION:** Many of the serial numbers for various items and components are filed on the Data Card located in the Warranty Information File box. Refer to the Manufacturer's individual Owner's Manuals for serial number locations that are not listed below.

**Motorhome** Serial Number \_\_\_\_\_

**Motorhome** Federal Vehicle Identification Number (VIN) \_\_\_\_\_

**Entry Door Key** Number \_\_\_\_\_

**Compartment Door Key** Number \_\_\_\_\_

**Cooktop/Range** Model & Serial Number \_\_\_\_\_  
(Located under top burner plate)

**Microwave** Model & Serial Number \_\_\_\_\_  
(Located behind door on case)

**Refrigerator** Model & Serial Number \_\_\_\_\_  
(Located inside refrigerator compartment)

**Generator** Model & Serial Number \_\_\_\_\_  
(Located in outside compartment on generator)

**Roof Air Conditioner** Model & Serial Number \_\_\_\_\_  
(Located under top cover on air conditioner)

**Inverter** Model & Serial Number \_\_\_\_\_



**FOR YOUR OWN REFERENCE**

**OWNER'S RECORD - INSURANCE**

Company: \_\_\_\_\_

\_\_\_\_\_

Policy #: \_\_\_\_\_

\_\_\_\_\_

Agent's Name & Address: \_\_\_\_\_

\_\_\_\_\_

Business Phone #: \_\_\_\_\_

\_\_\_\_\_

Emergency Phone #: \_\_\_\_\_

\_\_\_\_\_

Renewal Date(s): \_\_\_\_\_

\_\_\_\_\_

Notes: \_\_\_\_\_

\_\_\_\_\_

\_\_\_\_\_

\_\_\_\_\_

\_\_\_\_\_

\_\_\_\_\_

## **GLOSSARY OF TERMS**

**AC Electricity** - Alternating current also known as household power.

**Air Compressor** - A device that pumps air to and builds air pressure in an air system.

**Air Dryer** - A device that cools, filters and dries the air delivered by an air compressor.

**Air Governor** - A device that controls the operation of the air compressor by constantly monitoring air pressure in the supply tank of the air system. The air governor initiates the unload cycle when the cut-out pressure is reached. The air governor also controls the air dryer by sending an air signal (at the beginning of the compressor unload cycle) to the control port of the air dryer, initiating the purge cycle. When this air signal is removed by the governor (at the beginning of the compressor load cycle) the purge valve closes and the drying cycle begins.

**Ampere (Amp)** - The unit of measure of electron flow rate of current through a circuit.

**Ampere-hour (Amp-hr. AH)** - A unit of measure for a battery electrical storage capacity, obtained by multiplying the current in amperes by the time in hours of discharge. (Example: A battery which delivers 5 amperes for 20 hours, delivers 5 amperes times 20 hours, or 100 Amp-Hr. of capacity.)

**Black Water** - Term associated with the sewage holding tank. The toilet drains directly into this tank.

**Chassis Battery** - Powers chassis 12 Volt accessories and starts engine.

**Circuit** - An electric circuit is the path of an electric current. A closed circuit has a complete path. An open circuit has a broken or disconnected path.

**City Water** - A term associated with the water supply that you hook-up to when you are at campgrounds. It is called city water because you pull water from a central source (like in a city) and not the fresh water tank.

**Compressor Load Cycle** - The time during which the air compressor is building air pressure in an air system.

**Compressor Unload Cycle** - The time during which the air compressor is idling and is not building air pressure in an air system.

**Curbside** - This refers to the side of the motorhome which faces the curb when it is parked. Often called the door side.

**Current - Alternating (AC)** - A current that varies periodically in magnitude and direction. A battery does not deliver alternating current. Also referred to as shore power, utility power, inverter power, generator power, etc.

**Current** - The rate of flow of electricity or the movement rate of electrons along a conductor. It is comparable to the flow of a stream of water. The unit of measure for current is the ampere.

**Cut-In Pressure** - The pressure level in the air system supply tank which triggers the compressor load cycle.

**Cut-Out Pressure** - The pressure level in the air system supply tank which triggers the compressor unload cycle.

**Cycle** - In a battery, one discharge plus one recharge equals one cycle.

**DC Electricity** - Direct current also known as battery power.

**Desiccant** - A granular substance that has a high affinity for water and is used to retain moisture from the air stream flowing through the air dryer cartridge.

**Direct Current (DC)** - Power that is stored in a battery bank or supplied by photovoltaics, alternator, chargers and DC generators.

**Drain Trap** - This is a curve that is in all drains. Water is trapped in the curve and this creates a barrier so tank odors cannot escape through the drain.

**Dry Camping** - Camping in the motorhome when there is no city water hook-up or shore power. In other words, using only the water and power that is in the motorhome and not from another source.

**Drying Cycle** - The time during which the air dryer cools, filters and removes moisture from the air delivered by the air compressor. The drying cycle begins and ends the same as the compressor load cycle.

**Dump Station** - A site where the waste (grey) and sewage (black) tanks can be drained. In most states it is illegal to drain waste tanks anywhere other than at a dump station.

**Dump Valve** - Another name for the T-handle valve used to drain the sewage (black) and waste (grey tanks).

**Egress Window** - The formal name for the emergency window located in the rear of the motorhome. Egress windows can be easily identified by their red handles.

**Full Hook-Up Site** - A campground that has city water, shore power and sewer hook-ups or connections available.

**Grey Water** - Term associated with the waste water holding tank. Water from the sink drains, the shower and the washer/dryer (if equipped) go into this tank.

**House Battery** - Powers 12 Volt lights and accessories inside motorhome.

**LED** - (Light Emitting Diode) Indicator light.

**Low Point** - The lowest point in the plumbing. Drains are placed here so that water will drain out of the lower end of the motorhome. These drains must be closed when you fill the water tank.

**OHM** - A unit for measuring electrical resistances.

**Ohm's Law** - Express the relationship between volt (E), amperes (I) in an electrical circuit with resistance (R). It can be expressed as follows:  $E = IR$ . If any two of the three values are known, the third value can be calculated by using the above formula.

**Purge** - The initial blast of air (decompression) from the air dryer purge valve at the beginning of the air compressor.

**Purge Cycle** - The time during which the air dryer is undergoing purge and regeneration. This cycle starts at the beginning of the compressor unload cycle and normally ends well before the beginning of the compressor load cycle.

**Regeneration** - The mild backflow of air through the air dryer and out the purge valve that begins immediately after the purge and lasts normally 10 to 15 seconds. This backflow of air, from the air system and through the air dryer, removes moisture from the desiccant cartridge and prepares the air dryer for the next compressor load cycle.

**Road Side** - This refers to the side of the motorhome which faces the road when it is parked. Often called the off-door side.

**Shore Line** - This is the electrical cord which runs from the motorhome to the campground 120 Volt electrical supply.

**Shore Line Plug** - The 120 Volt outlet allows the motorhome to be hooked up to a campground facility.

**Stinger** - An arm attachment on a tow truck that is used to lift motorhome slightly so that it can be towed.

**TS1** - Terminal Strip One.

**VIM** - Vehicle Interface Module.

**Volt** - The unit of measure for electric potential.

**Watt** - The unit for measuring electrical power, i.e. the rate of doing work, in moving electrons by or against an electric potential.

**Wet Cell Battery** - A type of battery that uses liquid as an electrolyte. This type of battery requires periodic maintenance such as cleaning the connections and checking the electrolyte level.

## VENDOR LIST

### **Air Bags**

Firestone  
(317) 818-8600  
www.bridgestone-firestone.com

### **Air Conditioner - Roof**

Dometic Corp.  
(219) 463-4858  
www.dometic.com

### **Air Filter**

Camfil Farr  
877-837-3277  
www.camfilfarr.com

### **Alternator**

Leece-Neville  
800-349-2628  
www.prestolite.com

### **Awnings**

Carefree  
800-621-2617  
www.carefreeofcolorado.com

### **Axle - Front**

Westport  
(216) 431-2000  
www.westportaxle.com

### **Axle - Rear**

Dana Spicer  
800-666-8688  
www.dana.com

### **Batteries**

Interstate  
800-272-6548  
www.interstatebatteries.com

### **Battery Isolater**

Powerline  
800-443-9394  
www.hehrpowersystem

### **Brakes - ABS**

Meritor Wabco  
800-535-5560  
www.meritorauto.com

### **Brake (Hydraulic)**

Bosch Braking System Corp.  
800-521-5462

### **Brake (Exhaust)**

Pac Brake  
800-663-0096  
www.pacbrake.com

### **Carbon Monoxide Detector**

Safe-T-Alert  
800-383-0269  
www.safe-t-alert.com

### **Carbon Monoxide & Liquefied Petroleum Protectors**

MTI Industries, Inc.  
800-383-0269

### **Chassis Battery Charger**

Heart Interface  
800-446-6180  
www.heartinterface.com

### **Cooktop**

Atwood  
800-873-4328  
www.atwoodmobile.com

### **DVD Player**

Sony  
800-222-7669  
www.sony.com

### **Engine**

Cummins  
800-343-7357  
www.cummins.com



**Entry Step**

Kwikkee  
800-736-9961  
www.kwikkee.com

**Fan - Bathroom Exhaust**

Fan-Tastic Vent  
800-521-0298  
www.fantasticvent.com

**Filters**

Racor Fluid Filters  
800-344-3286  
www.parker.com/racor/

**Fire Extinguisher**

The Fire Extinguisher Co.  
(919) 563-4911

**Flooring**

Wilson Art  
800-433-3222  
www.wilsonart.com

**Furnace**

Atwood  
800-873-4328  
www.atwoodmobile.com

**Generator**

Onan  
800-888-6626  
www.onan.com

**Hitch Receiver**

Valley Industries  
800-344-3112  
www.valleyindustries.com

**Inverter**

Xantrex Technology  
800-446-6180  
www.xantrex.com

**Leveling Jacks**

Leveling Jacks - Hydraulic  
RVA  
(760) 746-5732

**LP-Gas Detector**

MTI Industries  
800-383-0269  
www.mtiindustries.com

**LP-Gas Tank**

Manchester  
800-753-8265  
www.mantank.com

**Microwave**

Sharp Electronics Corp.  
800-237-4277  
www.sharp-usa.com

**Monitor Panel**

KIB Enterprises  
(219) 294-1504  
www.kibenterprises.com

**Outside Mirrors**

Velvac Mirror  
800-783-8871  
www.velvac.com

**Radio - Dash**

Kenwood  
800-536-9663  
www.kenwoodusa.com

**Rear Vision System**

Jenson  
800-732-6866  
www.jensonaudio.com

**Refrigerator**

Norcold  
800-543-1219  
www.norcold.com

**Shock Absorbers**

Monroe  
800-880-7580  
www.tenneco-automotive.com

**Slide-out Motor (Main)**

Power Gear  
800-334-4712  
www.powergear.com

**Slide-out Motor (Bedroom)**

Power Gear  
800-344-4712  
www.powergear.com

**Steering Gear**

TRW  
800-879-0899  
www.trw.com

**Storage Trays**

Kwikkee  
800-736-9961  
www.kwikkee.com

**Television**

RCA  
(877) 266-2728  
www.rca.com

**Television Antenna**

Winegard  
(319) 754-0600  
www.winegard.com

**Tires**

Toyo Tire  
800-442-8656  
www.toyo.com

**Toilet**

Thetford  
800-521-3032  
www.thetford.com

**Transfer Switch**

ESCO  
(219) 264-4156

**Transmission**

Allison Transmission  
800-524-2303  
www.allison.com

**VCR**

RCA  
(877) 266-2728  
www.rca.com

**Water Heater**

Suburban  
(423) 775-2131  
www.suburbanmanufacturing.com

**Washer/Dryer**

Splendide  
(503) 655-2563  
www.splendide.com

**Water Pump**

Shurflo  
800-854-3218  
www.shurflo.com

**Wheels - Aluminum (Optional)**

Accuride  
800-626-7096  
www accuridecorp.com

**Window Blinds**

Carefree  
800-621-2617  
www.carefreeofcolorado.com

# SURVEY

## SAHARA 2002

Your suggestions are very important to us and we are continually striving to improve the quality of our manuals. After becoming familiar with your new recreational vehicle and the accompanying manual, please take the time to answer the following questions. When you are finished please return it to our Technical Publications Department. Feel free to attach an additional page if you desire.

**1. Is this your first recreational vehicle? YES / NO**

**2. Was the overall appearance and lay-out of this manual what you expected to see in your new recreational vehicle?**

---

---

---

---

**3. Was the information within this manual helpful in acquainting you with your new recreational vehicle? If not please address any area(s) we need to expand or improve on.**

---

---

---

---

**4. Were the operating instructions clearly written, and were you able to follow the steps without any difficulty?**

---

---

---

---

**5. Is there any additional information you would like to see incorporated within the owner's manual?**

---

---

---

---

**NAME:** \_\_\_\_\_ **PHONE:** (\_\_\_\_) \_\_\_\_\_

**ADDRESS:** \_\_\_\_\_

**SERIAL #** \_\_\_\_\_

CUT ALONG  
DOTTED LINE



FOLD

---

Place  
Postage  
Here

**TECHNICAL PUBLICATIONS  
MONACO COACH CORPORATION  
91320 COBURG INDUSTRIAL WAY  
COBURG, OR 97408-9908**

---

FOLD



CUT ALONG  
DOTTED LINE

# SAHARA

## SECTION 2 DRIVING & SAFETY

- DRIVING & SAFETY • 31**
  - Inspections • 31*
  - Familiarize Yourself • 31*
  - Safety Seat Belts • 31*
  - Tips for Driving • 32*
- CHECKLIST - PRE-TRIP PREPARATIONS • 35**
  - HITCH - Using the Rear Receiver • 37*
    - Tow Harness • 38*
  - REAR VIEW SYSTEM • 38**
  - BACKING UP A MOTORHOME • 39**
- CHECKLIST - SET-UP PROCEDURES • 41**
  - DRY CAMPING TIPS • 43**
  - BREAKING CAMP • 47**
- EMERGENCY PROCEDURES - ROADSIDE • 49**
  - Light - Retractable • 49*
  - Transmission - Rocking Out • 50*
  - Jump Starting • 50*
- TOWING PROCEDURES • 53**
  - TIRES • 54**
    - The Importance of Air Pressure • 54*
    - How Much Air Should I Carry in My Tires? • 55*
    - Tire Pressure Inflation Guideline • 55*
  - WEIGHT TERMS • 56**
    - Weight Label • 58*
  - WEIGHING THE MOTORHOME • 58**
  - TIRE CHART • 62**
    - Inspecting & Pressure • 62*
    - Tire Vibration • 64*
    - Tire Rotation • 64*
    - Tires - Supporting When Leveling • 64*
    - Storage of Tires - Long Term • 65*
    - In Case of Flat Tire • 65*
- TIRES • 54**
  - Testing • 72*
  - Alarm • 73*
  - Cleaning • 73*
- CARBON MONOXIDE DETECTOR • 74**
  - Operation Instructions • 74*
  - Alarm • 75*
  - Testing • 75*
  - Cleaning • 75*
- FIRE EXTINGUISHER • 75**
- EGRESS EXIT WINDOW • 76**
- VIEWES - Front • 68**
  - Rear • 68*
  - Roadside • 69*
  - Curbside • 69*
- SPECIFICATIONS - DIMENSIONS CHART • 70**
- SMOKE DETECTOR • 70**
  - Operation • 70*
  - How to Test • 71*
  - Maintenance • 71*
  - Troubleshooting • 71*
- LP-GAS DETECTOR • 72**





This section contains information on driving tips, emergency situations, towing, safety devices, weighing the motorhome and tires.

## DRIVING & SAFETY

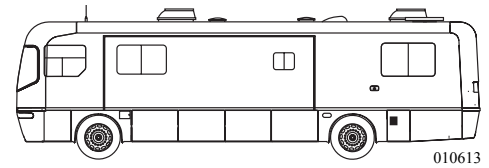

There are significant differences between a passenger automobile and a motorhome. Always be aware of these differences when traveling. The key to safely operating a motorhome is inspection. Any defect found could result in problems on the road that may cause lost time and money. Several states require that the motorhome be inspected prior to registration. Know and observe the laws of the state(s) in which you will be traveling. Laws may vary from state to state. A systematic inspection conducted prior to moving the motorhome will ensure nothing is overlooked and will assist in familiarizing the owner with the motorhome. Prior to moving the motorhome perform a general inspection which includes examining the condition of the vehicle and the surrounding area of the motorhome for hazards. Look high and low when walking around the motorhome.

### Inspections

The location of the driver's seat in the motorhome is higher and further to the left than most vehicles. This creates a different perspective of the roadway. Rely on the outside mirrors to line up with the center of the road and to check the conditions behind the motorhome. The dashboard may contain more gauges and controls than are normally found in passenger automobiles. Become familiar with these gauges and their indications before starting out.

### Familiarize Yourself

All occupants must be furnished with and use seat belts while the motorhome is moving. The driver's seat and all other seats designed to carry passengers, while the motorhome is in motion, are equipped with safety seat belts. Do not occupy beds or any seats that are not equipped with a safety belt while the motorhome is in motion. Seat belts must only be used on permanently mounted seats. The driver's seat must be locked in the forward facing position while motorhome is in motion. Do not use a seat belt on more than one person.

To fasten the seat belt, pull the belt out of the retractors and insert the tab into the buckle; you will hear a click when the tab locks into the buckle. Seat belt lengths automatically adjust to your size and sitting position. Do not route belts over armrest.

### Safety Seat Belts

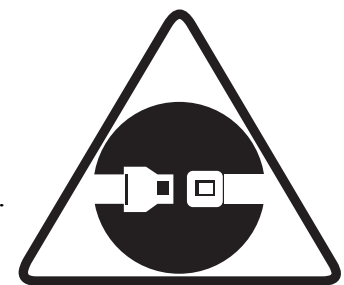

SEATBELT.eps



**WARNING: Seats must be pointed in a forward position and seat belts fastened while the motorhome is in motion. Avoid seat rotation while in transit. Children must not be transported unrestrained. Infants must be placed in approved safety seats. Small children must be restrained in child safety seats. Failure to comply with these rules can lead to injury or death.**



**CAUTION: Seat belts must only be used on permanently mounted seats. Do not use a single seat belt on more than one person.**

**Seat Belt Care:**

Keep the belt clean and dry. To clean, use a mild soap and lukewarm water. Never use bleach, dye or abrasive cleaners as they may weaken the belt. Inspect the belts periodically. Check for cuts, frays or loose parts. Replace any damaged parts. Do not disassemble or modify the system. Replace the belt assembly if it has been in a severe impact, even if damage is not obvious.

---

**Tips for Driving**

The motorhome is a complex vehicle and requires an increased level of driving awareness because of its size and various components. Due to the motorhome length the turning radius will be much wider than that of a standard automobile. Always pay close attention to all perimeters of the motorhome: front, sides, rear, roof and undercarriage. Insure the surrounding area is clear of obstacles. Utilize the driving mirrors to observe traffic conditions as well as the motorhome exterior: tires, bay doors, blind spots, etc. Use a push-pull method of steering, with both hands parallel on the steering wheel. The motorhome is also heavier than an automobile with a higher center of gravity. These factors affect the reaction time of the motorhome. Swerves and sharp turns, especially performed at high speeds, could result in the loss of control of the motorhome. Keep the size of the motorhome in mind and drive with extra caution to avoid situations which might require quick momentum changes. Increase reaction time by paying attention to traffic and road conditions 12-15 seconds ahead of the motorhome's position.

The motorhome will travel safely and comfortably at highway speed limits. However, it takes more time to reach highway speed. When passing another vehicle, allow extra time and space to complete the pass due to the added length of the motorhome. When descending a long hill, use the exhaust or engine brake. The transmission and engine will help control downhill speed and can extend the service life of the brake lining. The distance required to stop the motorhome is greater than an automobile. The brakes are designed for the (GVWR) Gross Vehicle Weight Rating. Practice stopping away from traffic to get the "feel" of the distance required to stop the motorhome.

When backing up, have the co-pilot stand at the road side rear corner so the co-pilot remains visible in the roadside mirror. The co-pilot can watch for any obstacles and give hand signals during the backing up process. When traveling, make sure bridges being crossed can support the weight of the motorhome. Check the tonnage limit of the bridges before crossing them. Signs should be posted at bridge entrances. Check the posted height of all overpasses or situations where overhead clearance is limited. Keep in mind, road surfaces may have been repaved or become packed with snow and therefore the actual posted clearance height would not apply in such conditions.





**Driving Cautions:**

- Avoid getting too close to the edge of the road, a soft shoulder may not support the weight of the motorhome.
- Side spacing is best maintained by keeping the motorhome centered in the driving lane.
- Driving lanes in work zones can be uneven, congested and narrower than usual.
- Be cautious of road debris which can damage the undercarriage of the motorhome or become lodged in the dual tires causing damage to the tires, wheel rims or tow car.
- Keep in consideration that posted speed signs are passenger automobile rated. Therefore, an extra awareness of the driving conditions and appropriate speed for a motorhome are necessary, especially on corners and mountain roads.
- Downgrade speed should be at least 5 mph less than upgrade speed, or downgrade speed should be attainable within three seconds of a brake application.
- Use a four second rule when following other vehicles at speeds under 40 mph. Use a five second rule when following at speeds over 40 mph.



**Right Turns:**

Negotiating a right hand turn in a motorhome can be difficult. Many drivers fear they can not make the turn without entering into the other lane or jumping the curb. Here are a few tips to make a right hand turn easier:

- As the turn approaches, look into the mirror to ensure the lane to the left is clear, then move wide over to the left.
- When you are about to make the turn; the left rear wheel should touch the center line of the road and your hips should be parallel to the roadside curb of the corner being turned. This will aid in avoiding a premature turn.
- Make the turn slowly.
- Check mirrors frequently being aware of the motorhome's necessary clearance and space management while negotiating the turn.

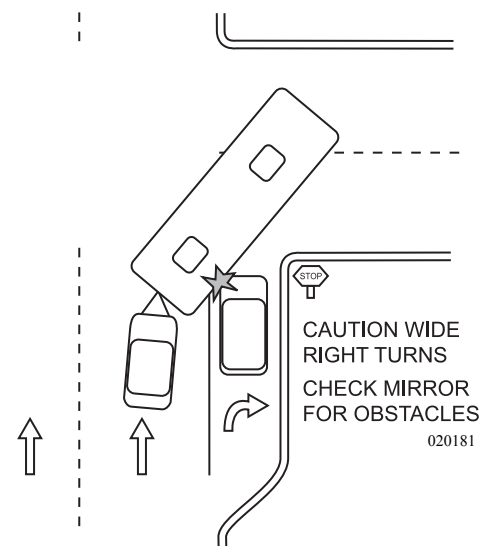

**Left Turns:**

- Do not start the turn until the center of the intersection is reached with your hips. If there are two lanes available, take the right hand lane. A car or driver on the left hand side is easier seen.

**Night Driving:**

- As always be well rested and alert when driving. If necessary, find a safe stopping place to rest until ready to continue.
- Avoid using any interior lights while driving. They can create a glare on the windshield, decreasing visibility.
- Dim the dash lights to a comfortable level to reduce the level of glare.

**Extreme Heat and Hot Weather Conditions:**

- Observe all gauges frequently. Any variations from the normal conditions should be evaluated promptly.
- Check tire pressure frequently when traveling in hot conditions. Tire air pressure increases with heat. It is not advisable to let air out of a hot tire. When the tires cool down they will return to the correct/previous tire pressure.
- Pay extra attention to hoses and belts which are more susceptible to fatigue in extreme heat.

**Winter and Cold Climate Conditions:**

- The motorhome should be prepared for Cold Weather Use.
- Keep speeds slow and steady. Make moves gradually and increase visual distance for a gain in reaction time.
- If road or weather conditions are treacherous find a safe stopping place and wait for conditions to improve.
- Avoid using an engine retarding device on wet or slippery surfaces, which can cause the drive wheels to skid.
- Wipers should be in good condition and the washer reservoir should have sufficient window wash fluid that has antifreeze included within it.
- Use the mirror heat to keep the mirrors clear.
- Remove any ice build-up from the entry step to avoid accidental slipping.

**Wet Conditions:**

- The risk of hydroplaning is increased if tires are worn or improperly inflated.
- Be aware that heavy rain or deep standing water can affect brake application causing them to apply unevenly or grab.

**Refueling:**

- Truck stops are good refueling points for motorhomes.
- Know which side the fuel port is on. There may not be adequate space to turn around in the parking lot to reposition for the pump.
- Check overhead clearance heights before pulling through the fuel island.
- Be aware of the concrete/steel posts installed around the fuel island.
- Avoid running over the fuel hose as it can get hung up on the motorhome, causing body damage.
- Use of gloves is recommended for refueling. Store the gloves in the outside compartment.
- To prevent grease and fuel deposits from being tracked into the motorhome when refueling, change shoes before entering the motorhome. Store the extra pair near the entry door.



**WARNING: Avoid the risk of fire or explosion. Turn off all pilot lights and appliances before entering a refueling station.**

Before departure several items will need to be prepared. Some suggestions are listed below. Use the lists as general guides when preparing to depart.

**Items To Carry:**

- Local, State and National Maps. Truck atlases can be useful for showing maps, refueling stations and truck repair facilities.
- An emergency road kit containing a flashlight, road flares, warning signs and a fire extinguisher.
- Potable/non-potable water hoses and a water pressure regulator.
- Hand tools.
- 12 Volt DC test light and a 110 AC Polarity Tester. These may be helpful when on the phone with a technician.
- A battery hydrometer to check the condition of battery electrolyte.
- A spare 12 Volt continuous duty solenoid (if applicable).
- An assortment of spare fuses.
- One link kit for ride height control assembly (air suspension only).
- A spare alternator belt.
- Charge air cooler T-bolt clamp.

**CHECKLIST  
- PRE-TRIP PREPARATIONS**

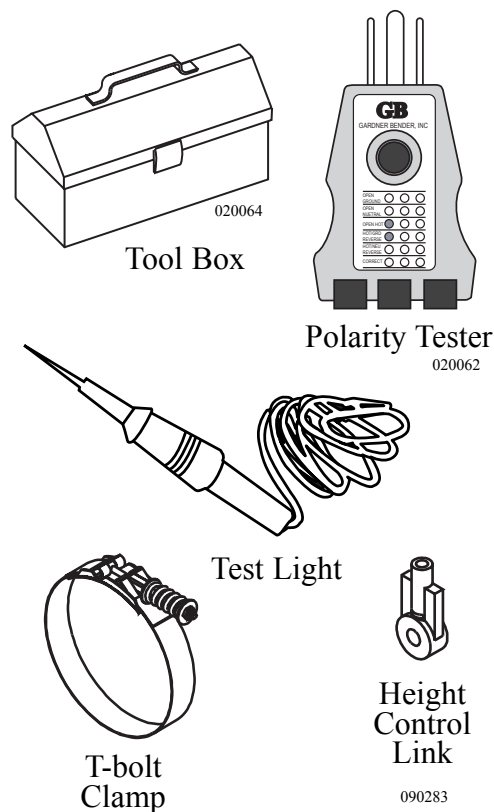

**Interior:**

- Start refrigerator operation the night before departure to get a head start on the cooling process. Pre-cool items prior to loading the refrigerator.
- If necessary, load pots, pans, utensils, soap, linens, etc.
- Secure and fasten the bi-fold and pocket doors. Lock the shower door.
- Close roof vents and windows.
- Secure any loose, heavy or sharp objects in case of a sudden stop.
- Close all cabinet doors and drawers.
- Walk the interior and check for items not secured.
- Turn interior lighting off.
- Certain floor models may require the bedroom television to be stowed. The latch must be in the locked position and the television secured.

**Engine Checklist:**

- Inspect the engine, transmission and the engine compartment for fluid leaks.
- Inspect the area under the motorhome for fluid leaks or puddles.
- Check all fluid levels, oil, antifreeze, transmission, hydraulic fluid and washer fluid.
- Inspect belts and hoses for wear.
- Inspect wiring for loose, frayed or corroded connections.
- Start engine and listen for any unusual noises.

**Driving Preparations:**

- Check operation of all exterior lights, headlamps, taillights, brake and clearance lights.
- Inspect fluid level (if applicable) in oil bath hubs.
- Fill the fresh water tank. Disconnect and store the fresh water hose.
- Check all tire pressures.
- Check both house and chassis battery condition.
- If applicable, program the navigation system.
- Secure all awning locks.
- Check items in storage bays to prevent shifting or damage to items.
- Outside compartment doors should be closed and locked.
- Look around, above and under the motorhome for obstructions.
- Check fuel level gauge. Check all other dash gauges for operation and correct level indications.
- Secure and lock the entry door for travel.

When using the rear hitch remember that the motorhome is intended for towing light loads. The motorhome is designed to be used primarily as a recreational vehicle. Towing will affect durability and economy. Safety and satisfaction require proper receiver use. Avoid excessive loads or other misuse. Weight pushing down on the rear hitch must not exceed 10% of the hitch capacity. It is recommended to weigh the motorhome when fully loaded to ensure proper weight distribution of the GCVW (Gross Combined Vehicle Weight). When weighing the motorhome add all passenger weight to the GCVW total. The motorhome fully loaded, and any vehicle or trailer towed by it, must not exceed the GCVW.

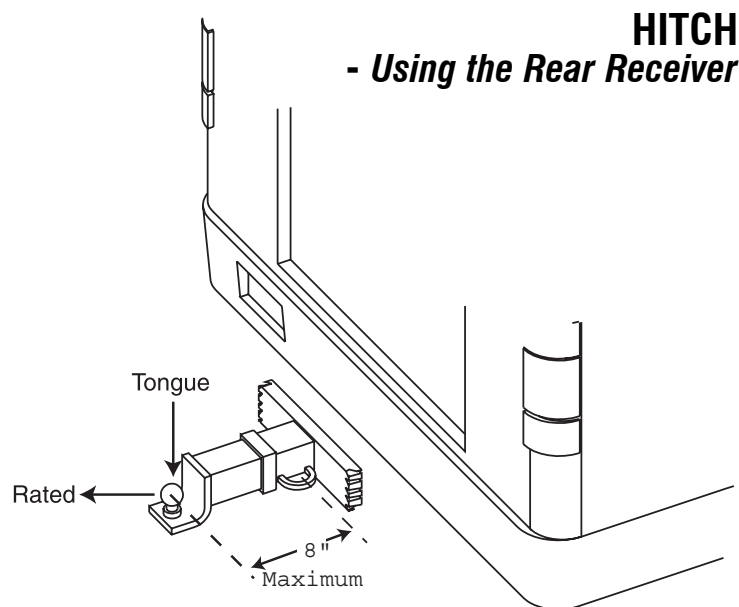

020065



**WARNING: Any trailer being towed by a motorhome must have adequate brakes. Failure to follow these instructions will create a safety hazard and may result in an accident.**

**HITCH CAPACITY**

CAPACITY WHEN USED AS A WEIGHT CARRYING HITCH  
DO NOT USE WITH A WEIGHT DISTRIBUTING (SPRING BAR TYPE) HITCH

**5,000 LBS. MAX. GROSS WEIGHT**  
**500 LBS. MAX GROSS TONGUE WEIGHT**

ALL FASTENERS MUST BE OF GRADE 5 QUALITY  
TRAILER BRAKES ARE RECOMMENDED FOR TOWING LOADS IN EXCESS OF 1,500 LBS.

WARNING: ALTHOUGH THIS HITCH IS DESIGNED TO SAFELY TOW ITS RATED LOAD  
WE RECOMMEND THAT YOU CONSULT YOUR VEHICLE OWNERS MANUAL  
FOR POSSIBLE MANUFACTURER'S RECOMMENDATIONS OR LIMITATIONS

020128b

### **Tow Car or Trailer:**

1. Connect tow car or trailer with light harness to motorhome and perform a light check.
2. Connect safety chains.
3. Check the tow car or trailer and the motorhome before starting a trip and at each rest stop.
4. Flat tires on a towed vehicle cannot be detected from the motorhome while driving. A flat tire is a safety hazard and may cause extensive damage. Check tires on the tow vehicle frequently.

## Tow Harness

The motorhome is pre-wired from the factory with an electrical harness for towing. The harness is located on or near the hitch receiver. Convoluted tubing protects the tow harness wires until ready for use. Current draw should not exceed ten amps for each designated light circuit. Depending on the light configuration of the tow car, an electrical taillight converter may be required.

All tow harness wires are white with alphanumeric identification:

- 12 gauge - # 56 Ground.
- 14 gauge - # 88 Right Turn Signal.
- 14 gauge - # 87 Left Turn Signal.
- 14 gauge - # 106 Brake Light.
- 14 gauge - # 88 Park Lights.

When preparing a tow plug connection strip the wires 3/8". Twist the wire strands together. Place the wire under the clip and secure the screw. Make sure there are no loose strands of wire that could short against the case or other terminals. Do not accidentally mirror image the trailer connection.

## REAR VIEW SYSTEM

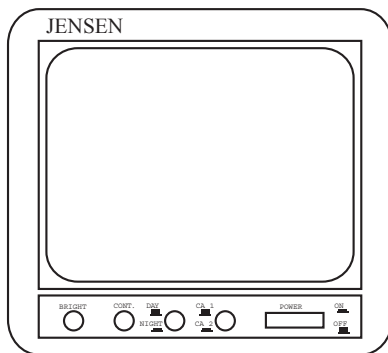

080248

The rear view system is designed to provide the driver with a view of the rear of the motorhome. The field of view is 140° in the diagonal plane, 121° in the horizontal plane, and 90° in the vertical plane. Power is supplied to the system when the ignition key is turned to the Accessory or **ON** position. The **green** LED illuminates. The display on the monitor is controlled by the position of the power switch. When in the **ON** position, the display is present. When placed in the **S/B** (Standby) position, the display is off until the gear shift lever is set to **Reverse**.

### Power Switch:

The switch, when **ON** (in) position, turns on the monitor for viewing. The **green** LED indicator illuminates. When the switch is **OFF** (out), the monitor is in a **STANDBY** mode of operation. The **green** LED remains illuminated when the ignition is on. The monitor displays rear viewing when the transmission is shifted to **REVERSE**.

### Camera Selector:

This switch should be left in the **CA1** (out) position. **CA2** (in) position is not used in the motorhome.

**Day/Night Switch:**

This switch should be left in the **DAY** (out) position for normal viewing. When set in **NIGHT** (in), picture brightness is reduced. **NIGHT** should be used for night viewing and driving through tunnels.

**Bright Control:**

Clockwise rotation increases the picture brightness. Counterclockwise rotation decreases the picture brightness.

**Contrast Control:**

Clockwise rotation increases the picture contrast. Counterclockwise rotation decreases the picture contrast.

**Audio Control:**

Clockwise rotation increases the volume level. Counterclockwise rotation decreases the volume level.

The camera angle may be adjusted to display a suitable rear view. The camera housing cover will need to be removed to gain access to the hexagon mounting bolts. The mounting bolts can be repositioned to the desired angle. Refasten the camera housing cover and seal using an appropriate sealant.

---

If the destination does not have “pull-through” sites try to pick a solid, level site. If possible, pick a site located on the left side. The driver will have a better field of vision by using the driver side mirror. If the site is on the right side the driver will have to use the passenger side mirror for backing up, which leaves a blind spot. When a potential site is spotted, stop the motorhome before the site. Get out and observe the area for soft ground, posts, large rocks, low hanging limbs or other obstacles. If the site meets your criteria, prepare to back in carefully.

Backing up can be a challenge for even a long-time owner of recreational vehicles. Follow some simple guidelines to help reduce the challenge. When backing up, the driver (pilot) should be comfortable using the mirrors, the back-up camera and the co-pilot’s directions (ground guide) for assistance. Practice backing up, with the co-pilot’s guidance, in a large unobstructed parking lot. Backing up a motorhome is a team effort.

The backing up process should begin while the motorhome is in forward motion. Maneuver the motorhome to align it with the chosen site. This allows straight alignment with the site. Aligning the motorhome with the site will require considerably more room than an automobile and may require more than one attempt. When the motorhome is properly aligned with the site, the parking area will be visible in both mirrors. Use straight lines, such as road markings, as reference points when possible.

**BACKING UP  
A MOTORHOME**

The co-pilot's job is just as important as the driver. When guiding the driver, the co-pilot should be located safely at the left rear corner of the motorhome, facing forward, while remaining visible in the driver side mirror at all times. The co-pilot should make a conscious effort to maintain sight of the driver through the driver side mirror as the front of the motorhome maneuvers. If the driver loses sight of the co-pilot, stop the backing up process until the co-pilot is in view. To avoid mishaps, the co-pilot should be focused only on what the driver is doing, with brief observation moments. The driver should receive directions only from the co-pilot. If necessary, stop the backing up process to have co-pilot inspect other areas or angles of concern. Use of walkie-talkies will aid in guidance.

Five clearly defined signals should be used, with only one signal given at a time, when the co-pilot is guiding the driver. Flailing arms with indecisive signals only confuse the driver. Signals should be precise. Directional signals are directing travel of the rear of the motorhome.

If desired direction is left, the co-pilot points left. For example: The co-pilot uses his/her right arm and forefinger to point distinctly left, with arm and finger held on a horizontal plane, to indicate the desired direction of travel of the rear of the motorhome. This type of directional signal can be easily discerned in the mirror by the driver. The directional signal given should remain steady until the desired movement is completed.

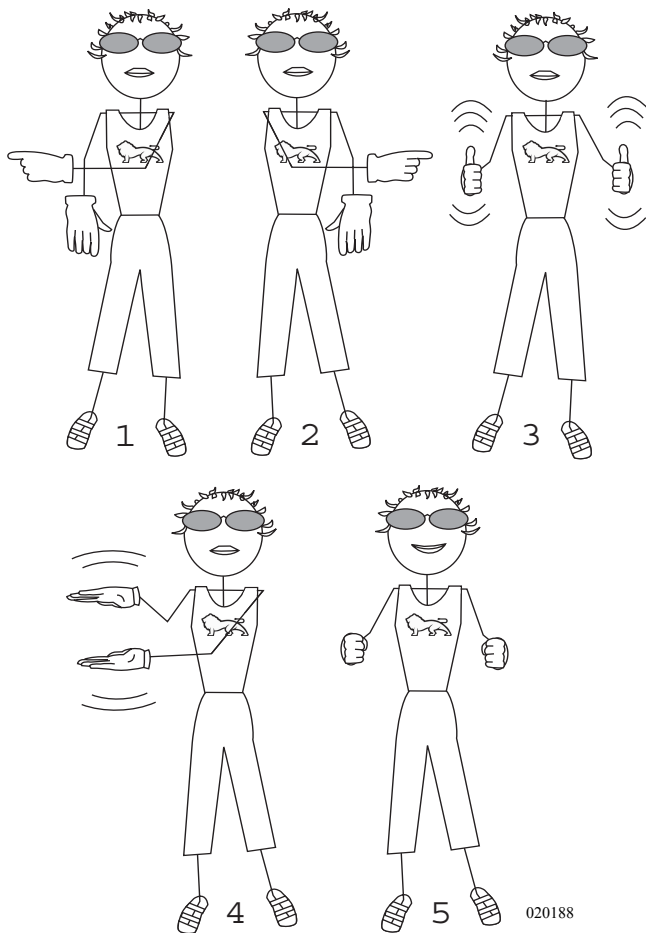

**The five directional signals are:**

1. Co-pilot uses left hand and arm held horizontal with forefinger pointing right to direct rear of motorhome to the right.
2. Co-pilot uses right hand and arm held horizontal with forefinger pointing left to direct rear of motorhome to the left.
3. Co-pilot uses both arms and hands parallel with thumbs pointing up and to rear in a waving vertical motion. This signals driver to maintain a straight back direction.
4. Co-pilot holds arms vertically, hands open with palms facing one another. Start with a wide separation, gradually closing distance of hands in a rate appropriate to vehicle speed to indicate the amount of distance to stop point.
5. Closed fists indicates STOP.



**Backing Up Trailers:**

Trailers have only one pivot point. Trailers may be backed up. Towed vehicles using a tow bar or tow dolly have more than one pivoting point which makes this type of equipment not suitable for backing. If using this type of towing equipment, plan ahead. Park safely along the road and walk a distance if necessary to avoid a possible back up situation. Avoid putting the motorhome and tow vehicle in a backing situation. To back up this combination, completely disconnect the tow vehicle from motorhome. Trying to back up the motorhome with a tow vehicle connected will result in damage to the motorhome, tow vehicle and towing device.

The same rules for backing a motorhome may be applied when backing a trailer. When preparing to back a trailer into a space, maneuver the motorhome sweeping wide, then turn back to the opposite direction. This will set the motorhome and trailer in a position to maneuver the trailer into space. When backing a trailer, the driver may become disoriented with the direction of the steering wheel and the direction of the trailer. The bottom of the steering wheel must be moved in the desired direction of the trailer. For example: If the desired direction of the trailer is left, rotate the bottom of the steering wheel left. If the trailer moves in an undesired direction, use a short “pull-up” method, pulling forward just far enough to align the trailer with the space. The co-pilot should stand safely at the left rear corner of the trailer within view of the driver in the driver side mirror, using the five hand signals for guiding.



**CAUTION: Tow bars or car dollies generally are made to travel in a forward direction only. Most towing equipment of this type is not designed for backing. Never attempt short back up distances with a tow bar or tow dolly. Damage to the motorhome, vehicle or towing device will result.**

If the site for the motorhome has full hook-ups, use this quick reference hook-up checklist. This hook-up list is only a guide. This checklist has information on hooking up the utilities and preparing the appliances for use. Specific information on the slide room, awning and leveling system operations is discussed in detail in other sections.

- Check for lateral clearance before extending the slide-out room.



**NOTE: To operate the kitchen slide: The ignition must be OFF, the park brake must be set.**



**CAUTION: Before leveling the motorhome survey the area around and under the motorhome for obstructions which can damage the motorhome or undercarriage components when the air bags are deflated.**

## CHECKLIST - SET-UP PROCEDURES

- Follow the procedures and guidelines for “Leveling the Motorhome.” If the motorhome is equipped with hydraulic jacks, be certain the parking surface will accommodate the weight placed on the jacks.



**CAUTION: Hot asphalt may not support the weight that is placed on the hydraulic jack pads. Place thick plywood under the jack pads to help disperse the weight. Never use the leveling system to support the entire weight of the motorhome. Damage from excessive torsional twists can result.**

- Open the LP-Gas tank valve.
- If possible, begin appliance operation on LP-Gas for the first 60 minutes. Switch the refrigerator operation to gas, start the water heater and furnace (if needed). This will allow time for the inverter to stabilize the battery charging.
- Prepare the shore cord to be plugged in. Uncoil and inspect the cord. Perform any necessary cord maintenance. Install proper electrical adapters if anything other than 50 Amp service is provided. Operate electrical appliances in sequence when hooked to a limited shore power service. Turn shore power circuit breaker OFF prior to plugging in the shore cord.

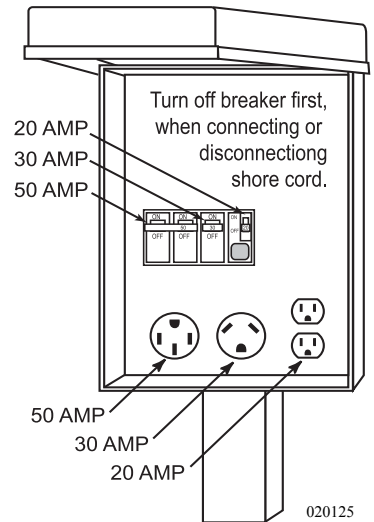

**CAUTION: If shore power service is limited to 15 or 20 Amps, use of light duty extension cords and electrical adapters will create a voltage loss through the cord and at each electrical connection. Line voltage loss and the resistance at each electrical connection can be a hazardous combination. Damage to sensitive electronic equipment may result!**

- If cable service is provided, hook-up a 75 Ohm RG59 or RG6 cable to the cable connection in the service center. If the motorhome has a video selector box press the appropriate viewing button for the item desired.
- A phone connection port is provided in the service center. Phone utility outlets are placed throughout the motorhome, including a phone line attached to the satellite receiver for Pay-Per-View movies and events.
- Hook a potable water hose to the city water connection in the service center. A water pressure regulator is built in. Turn the hand valve so the pointer indicates “city water.”



**NOTE: A water pressure regulator attached between the city water faucet and the potable fresh water hose will protect the hose from swelling or bursting under high city water pressure. Securing the pressure regulator to the hose with pliers will prevent the regulator from being misplaced.**

- Hook-up the sewer hose. Sewer drain pipe diameters are generally either three or four inches. Proper sewer hose adapters will ensure against leaks or spillage. With the sewer hose properly connected open the grey water valve (small valve). The black water valve (large valve) remains closed until the tank is full or until time of departure.

---

Plan ahead and conserve resources while dry camping.

Dry camping requires fully charged and properly maintained batteries (corrosion cleaned, terminals tightened, cables checked, etc.). If battery water is low, fill the batteries with distilled water only. Water containing a high concentration of minerals will alter the battery's chemistry reducing battery capacity and performance. Before arriving at your destination, fill up with fuel for the generator.

Begin with a full fresh water tank and empty waste holding tanks. When the fresh tank is low, the waste holding tanks will more than likely be full. Empty the waste holding tanks before refilling the fresh water tank.

Solar panels are a valuable addition to help charge the batteries. If the motorhome is equipped with two panels, the first panel will offset the parasitic loads. The second panel (and adding a third if possible) will charge the batteries during daylight hours. Clean the solar panels regularly for optimum performance. Dust, dirt, grime and pollution from the road and air will decrease their efficiency. Clean the solar panels with window cleaner and a soft cloth.

Most dry camping locations can accommodate motorhomes of various lengths. Confirm that the facility you plan on visiting can accommodate your motorhome's length and size. Arrive during daylight hours to properly set-up the motorhome and prepare for the night ahead. Getting to a site on narrow and winding campground roads takes skill and patience. Avoid low hanging limbs, tree trunks and barriers lining the roadway. Have the co-pilot or the campground host provide assistance when maneuvering the motorhome around curves and bends.

When dry camping, hookups are not a concern. Take extra time to properly set-up. Make sure there is plenty of space to extend the slide-out room(s). Before lowering the air suspension and leveling the motorhome, check underneath for obstacles that may damage undercarriage components.

For motorhomes equipped with automatic leveling, be sure people and pets are not moving in the coach during the leveling process. When leveling manually, interior movement is less critical.

## **DRY CAMPING TIPS**

**Setting Up for Dry Camping:**

- Switch refrigerator operation from Auto to LP-Gas.
- Operate the water heater on LP-Gas. Turn it on about an hour before hot water is needed.
- If the furnace is needed during the nighttime, set the thermostat temperature a bit lower preventing the furnace from cycling all through the night.
- Check on small items that use battery power, such as the porch light, bay lights, the light under the step, generator compartment lights, engine compartment lights, etc. If the television is not being used, turn off the 12 Volt booster. Even one light accidentally left on, such as under the front cap, reduces battery reserves quickly.
- Some battery draw is unavoidable. The battery cut-off switch at the entry door must be on to operate many interior items such as lights or the furnace.
- Keep flashlights handy. Build a campfire when spending nighttime hours outdoors. Extinguish the flames before retiring for the evening. Many campgrounds place wood or cement barriers between the site space and fire pit. Illuminate any barriers or obstacles in the pathway to the motorhome.
- Place a large flashlight inside the front door for navigating through the coach during the night without having to use interior lights. If interior lighting is needed, use one light in a central location, such as the vanity.
- During the day it is still important to conserve on energy. Turn on the water pump only when using water. Turn the pump off when not in use. The water pump does not draw an abundance of power, however all battery amp hours are important and should be conserved.
- If it is too early in the morning or too late in the day to run the generator, use the inverter for AC power. Remember to turn off the inverter when not in use. When the rest of the campers are up and about, turn on the generator and run it for a couple of hours to help charge the batteries. The generator may seem loud, however, the noise is minimal just a short distance away from the coach. Run the generator during clean up and preparation for the day.
- Check the monitor panel frequently and keep track of water usage and battery consumption. Routinely check the LP-Gas level. Remember the furnace uses more gas in cold weather.

- Careful management of water is critical when dry camping. Know the motorhome tank capacities. Picture the amount of liquid in a gallon container. Visualize that amount each time you run the water. If you are dry camping for extended period, limit shower usage. Turn the water off when soaping down in the shower. If water conservation is critical, take a sponge bath. Conserve water while brushing your teeth. Chances are a campground without hookups will not have large comfortable shower rooms or bathrooms. It may only be equipped with primitive facilities, however, if it helps to economize on water, use them.
- Do not fill the sink full of water to wash a few dishes. Use disposable dishes whenever possible. Conserve propane by cooking dinner over the campfire. However, if cooking over the campfire is not desired, use the cook top or microwave. If you use the inverter to operate the microwave, battery power will be consumed quickly. If possible, use the generator to operate the microwave. It is healthy for the generator to operate under a heavy load such as the microwave.
- Allow the generator to power up for a couple of minutes before applying a load.
- To conserve on battery power, plan what is needed from the refrigerator prior to opening it. If weather does not permit eating at the picnic table, or if no picnic table is available, eat at the dinette table by candlelight.
- Leave shoes outdoors or at the entry step to avoid tracking in dirt. Open windows during the day instead of using the roof air conditioner.
- Get back to nature and still enjoy the comforts of the motorhome. With a little imagination, the ways to conserve available resources while dry camping are endless.

**Typical Current Draw:**

- One continuous duty solenoid is a .7 Amp draw, two solenoids will be a 1.4 Amp draw.
- A 13" TV has a 1.7 Amp draw.
- Rope lights (10 ft) are a 1.3 Amp draw.
- The porch light is a 2.0 Amp draw.
- One fluorescent dual bulb light has a 2.1 Amps draw.
- One halogen ceiling light has a .09 Amp.

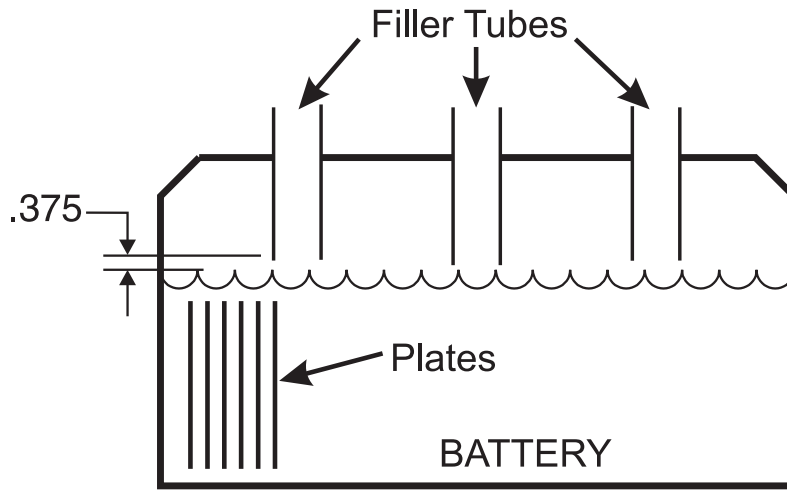

The distilled water level in the battery should be 3/8" below the vent tube. 020034

<b>Battery State of Charge vs Voltage/Specific Gravity</b>			
<b>VOLTAGE</b>	<b>SPECIFIC GRAVITY</b>	<b>STATE OF CHARGE</b>	<b>DEPTH OF DISCHARGE</b>
<b>12.66</b>	<b>1.265</b>	<b>100%</b>	<b>0%</b>
<b>12.45</b>	<b>1.225</b>	<b>75%</b>	<b>25%</b>
<b>12.25</b>	<b>1.190</b>	<b>50%</b>	<b>50%</b>
<b>12.05</b>	<b>1.145</b>	<b>25%</b>	<b>75%</b>
<b>11.90</b>	<b>1.100</b>	<b>0%</b>	<b>100%</b>

Battery Voltage: Fully charged with battery at rest for one hour.

Battery Charge Voltage chart

**BREAKING CAMP**

Below is a checklist guide to reference when preparing to break camp. Preparing the motorhome for travel will require several small tasks. Properly securing and storing items will help prevent them from getting lost or being damaged during travel.

**Outside Checklist:**

- Disconnect the cable TV, lower the television antenna and (if applicable) the satellite dish.
- Disconnect and stow the phone line.
- Retract the awnings and secure them for travel.
- Close LP-Gas tank valve. Check the level of the LP-Gas Tank to ensure a sufficient amount is available.
- Drain and flush the holding tanks. First close the grey water valve, run enough cold water down the sink and shower drains until the grey tank is at least 50% full. Be careful not to overfill or flood the grey tank. Next, open the black tank valve allowing the drain cycle to complete. **If applicable**, connect a **non-potable** water hose to the No-Fuss hose bib and flush the black tank system. Close the black tank valve, open the grey water valve. The water from the grey tank will help flush the solids from the drain hose.
- Disconnect the sewer hose. Flush hose with clean water from **non-potable** hose. Store the hose. Install the sewer cap.
- Fill the fresh water tank (using the potable hose). Disconnect and store the fresh water hose. Remove any hose protected water pressure regulator from the city water faucet.
- Turn shore power breaker off and disconnect the shore line. Wind up and store the shore cord.
- Inspect fluid level in oil bath hubs (if applicable) and check all tire pressures.
- Secure all compartment doors and entry door.
- Inspect tires and wheels.
- Check for fluid leaks under or around the motorhome.

**Engine Checklist:**

- Inspect the engine, transmission and the engine compartment for fluid leaks.
- Inspect the area under the motorhome for fluid leaks or puddles.
- Check all fluid levels: oil, antifreeze, transmission, hydraulic fluid and washer fluid.
- Inspect belts and hoses for wear.
- Inspect wiring for loose, frayed or corroded connections.
- Start engine and listen for any unusual noises.
- Inspect gauges and controls for proper operation.

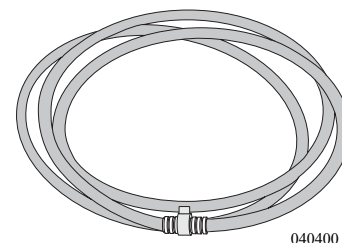

040400

*Screw the ends of the hose together before storage to prevent leakage and to prevent dust and insects from entering the hose.*

**Interior Checklist:**

- If applicable, retract leveling jacks allowing the air suspension to obtain proper ride height.
- If applicable, clear the slide room path, clean the floor, move the driver seat forward and make sure the bay doors are shut. Retract the slide room. When the slide room is fully retracted secure any slide room awning locks.



**NOTE: To operate the kitchen slide the ignition must be OFF, the park brake must be set.**

- Secure and fasten the bi-fold and pocket doors. Lock the shower door.
- Close roof vents and windows.
- Secure any loose, heavy or sharp objects in case of a sudden stop.
- Close all cabinet doors and drawers.
- Turn off interior lights.
- Turn off water heater, water pump and furnace.
- Walk through the interior and check for any unsecured items.
- Turn the interior lighting off.
- Check the fuel level gauge. Check all other dash gauges for operation and correct level indications.

**Departure Checklist:**

- Check items in storage bays to make sure shifting or damage of items will not occur.
- Look around, above and under the motorhome for obstructions. Check for debris stuck between the rear dual tires.
- Walk around the motorhome and camp area checking for forgotten items.
- Outside compartment doors should be closed and locked.
- Check operation of all exterior lights, headlamp, taillamp, brake and clearance lights.
- Carefully pull forward out of the campsite. If necessary, clean the site and check for any forgotten items.
- Secure and lock the entry door for travel.



If an emergency situation occurs, use the appropriate braking technique and pull off the roadway a safe distance from traffic (if possible). Set the parking brake and turn on the hazard warning flashers, especially when parked alongside traffic lanes. In the event of an emergency stop due to a mechanical breakdown or other motorhome related problems, contact the manufacturer's **Customer Support** at **(1-877-466-6226)** or an emergency service provider.

An emergency road kit should include at least three reflective warning signs, road flares, a flashlight, spare automotive fuses and an assortment of hand tools. For added safety a separate fire extinguisher should be considered. The motorhome is equipped with a fire extinguisher located inside next to the co-pilot seat. Road flares or reflective warning signs should be displayed if the motorhome is alongside of the road for any length of time.

Guidelines for placing the warning triangles depend upon the road characteristics and visibility. For example: The standard placement is 10 feet, 100 feet and 200 feet from the rear of the motorhome when on a divided highway or one-way road. On a two-way road, with traffic traveling both directions, the same placement would also be required at the front of the motorhome. Roads with curves and hills may require the placement of the last/furthest triangle to be 500 feet behind the motorhome in order to safely warn approaching traffic.

## EMERGENCY PROCEDURES - ROADSIDE

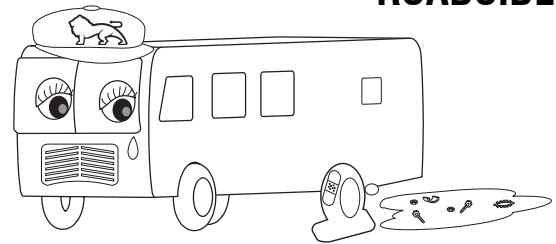

020170d

The retractable light is located in places of limited lighting for emergency purposes. Normally, one will be located in the engine service compartment and with the entertainment hook-up in the bay.

### Light - Retractable

#### To use:

1. Activate light by moving **ON/OFF** switch to the **ON** position.
2. The light is on an 18' retractable reel cord. To operate, lift the lever and pull the light out.
3. The light has a magnetic base attached. Locate a place to attach the light so you can work hands free.
4. To replace bulb push down on clear plastic cover and twist.
5. To rewind, crank the handle in the retract direction. When it is fully retracted, push down on the lever handle to keep the light locked into place.

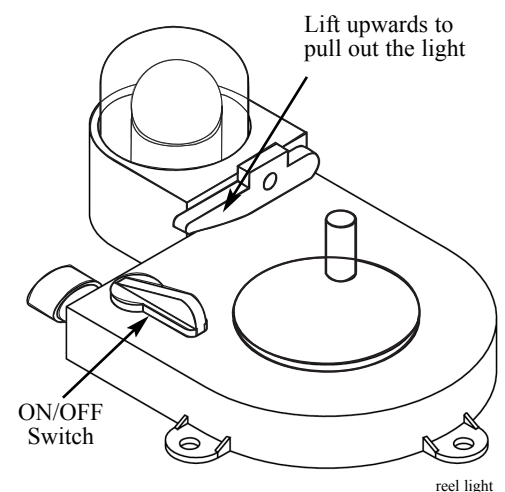

## Transmission - Rocking Out

It may be possible to rock the motorhome out if it is stuck in snow, mud or deep sand. Shift the selector to **D** (Drive) and apply steady light throttle. Never apply full throttle as the wheels may spin and bury the motorhome deeper. When the motorhome has moved forward as far it will go, apply and hold the service brakes. Allow the engine to return to idle before selecting the **R** (Reverse). Release the brake and apply light throttle until the motorhome has rocked as far it will go. Again apply the service brake and allow the engine to return to idle. Repeat this process if the motorhome has moved a greater distance. If the process does not free the motorhome call for towing assistance.



**NOTE: Sudden movements or lurching the motorhome with an open throttle can result in damage to the transmission. Avoid this condition by making shifts only when the throttle is closed and engine is at normal idle.**

## Jump Starting

### Alternative Starting Procedure:

A weak or discharged battery will not supply the amount of CCA (Cold Cranking Amps) necessary to initiate and maintain cranking the engine while supplying the required voltage to start the engine. If the engine fails to crank, or cranks slowly due to a weak chassis battery, there are electrical back-up systems in place that will increase chassis battery voltage.

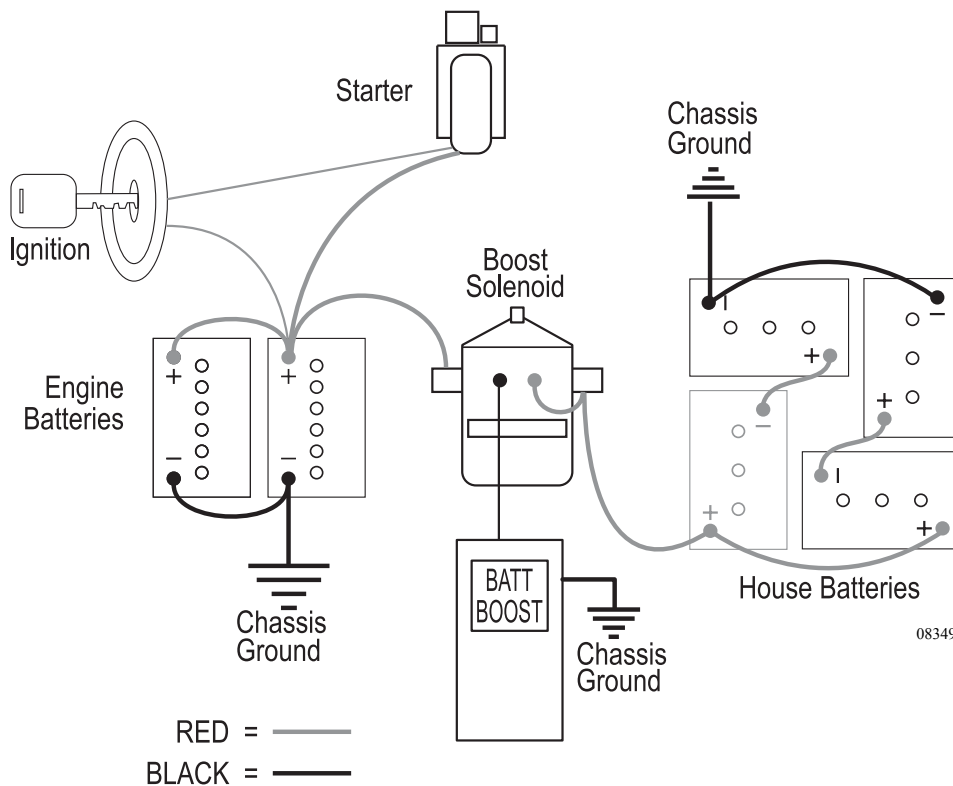

### Battery Boost Switch:

The Battery Boost switch engages a heavy-duty solenoid to electrically connect the house batteries to the engine battery in the event the engine won't crank or cranks slowly. The solenoid is designed for short-term high current intermittent use. Engaging the boost solenoid for an extended period will damage the solenoid.

### To Use the Solenoid

- With the ignition key off, press and hold the Battery Boost switch for 10 seconds. After 10 seconds, continue to hold the switch down and try to start the engine.
- If the engine fails to crank, or does not crank fast enough, discontinue the attempt. Continued attempts only diminish any remaining surface charge in the chassis battery, ending any future alternative attempts.
- Next, start the generator. This may require using the Battery Boost switch as the generator starts from the engine battery. When the generator is operating, the electrical combination of the generator, inverter and (if applicable) battery maintainer will charge the batteries.
- Allow the generator to run approximately ½ hour before attempting to start the engine.
- After a ½ hour of generator operation, with the generator operating, hold the down the Battery Boost switch for one minute. Release the switch for one minute, then engage the switch for one minute. Alternate this cycle 3-5 times. This will avoid overheating the Boost solenoid.
- Next, hold the switch down for one minute and turn the key on. The battery voltage gauge on the dash should indicate at least 12 Volts. If voltage is sufficient with the Boost switch held down, try starting the engine.
- If the engine fails to crank, or fails to crank quickly, the chassis battery may be depleted and the motorhome will require jump-starting or an external charger hooked to the chassis battery. When using jumper cables to start the engine, the cables must connect in a parallel configuration. That is positive (+) to positive (+) and negative battery (-) to negative chassis (-). Always connect the positive (+) before connecting the negative (-). To prevent arcing when disconnecting the cables, disconnect the negative (-) before disconnecting the positive (+).

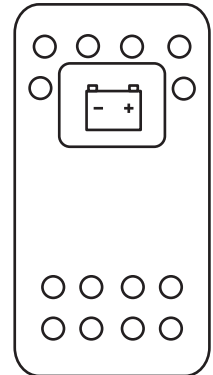

080366



**WARNING: Batteries can emit explosive gases. Always ventilate the battery compartment prior to any work or service to the batteries. Extinguish all smoking material and keep all open flame and spark producing devices away from battery area.**



**CAUTION: A large amount of electrical current is required to jump-start an engine. The sizes of the battery, alternator and jumper cables supplying the "jump" are current limiting factors. Voltage fluctuations that occur during a jump-start procedure can damage sensitive electronic equipment and charging systems. Wait a sufficient amount of time for a surface charge to build before attempting to crank an engine when using a jump-start procedure. If uncertain about performing a jump-start procedure, contact a professional. Damage and personal injury can occur if this not procedure is not performed correctly.**

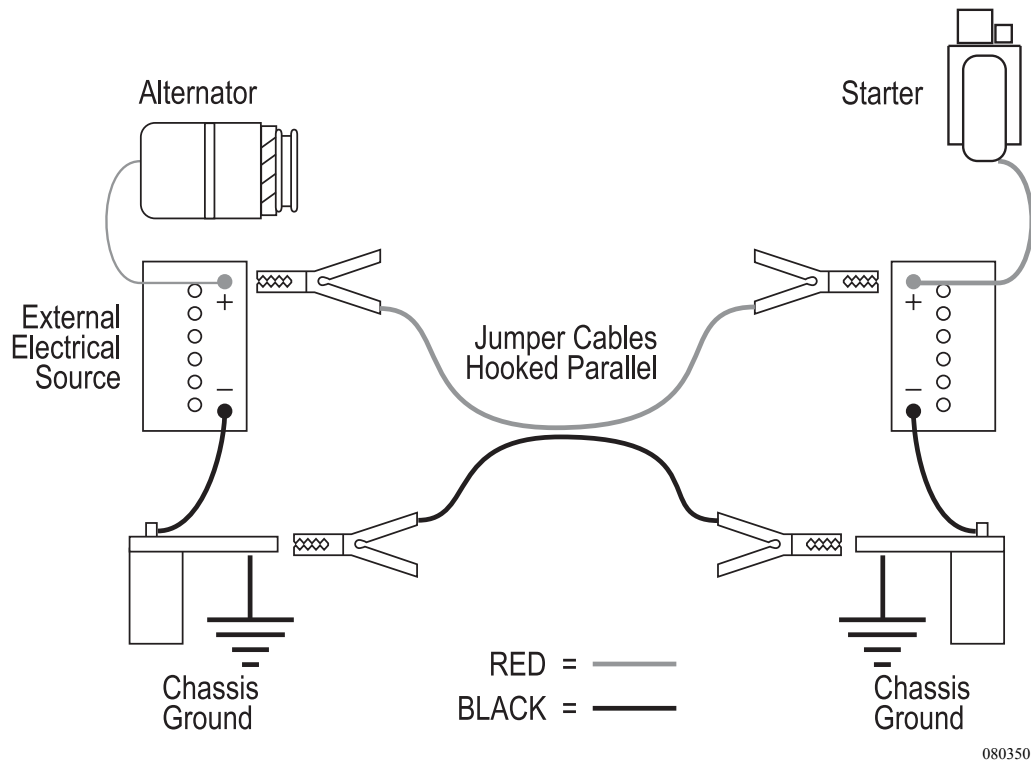

### Jump Starting:

- When using an external electrical source to connect to the chassis battery, turn the main battery disconnect switches **OFF** prior to hooking up the jumper cables.
- Hook up the cables then wait several minutes to allow a surface charge to build in the chassis battery before attempting to start the engine.
- Turn **ON** the battery disconnect switches and attempt to start the engine. **DO NOT** crank the engine more than a few seconds.
- After the engine has started disconnect the cables. Disconnect the negative (-) cables before disconnecting the positive (+) cables to prevent arcing.
- If the engine does not crank, or cranks slowly, **DO NOT CONTINUE**. Seek professional help. Extensive damage, fire or injury can occur.

In the event of a roadside emergency, contact the nearest **Cummins Center at 1-800-DIESELS (800-343-7357)** for Cummins Customer Assistance Center.



**WARNING: The gases around the battery can explode if exposed to flames, sparks or lit cigarettes. An explosion can result in injury or vehicle damage. Batteries contain sulfuric acid, which burns skin, eyes and clothing. Do not connect the end of the second cable to the negative (-) terminal of the battery to be jumped. A spark may cause an explosion of the gases that surround the battery. Connect only to the chassis, away from the battery.**

**TOWING  
PROCEDURES**

If calling a towing company for service, it is recommended to use a lowboy/landall type of trailer. If a tow truck is used it needs to have a support arm that goes under the motorhome and secures to the front axle. Inform the tow company of the axle weights and total weight of the motorhome. Other important information is the length of the motorhome, number of passengers and mile-post location. Two tow trucks may be necessary. One to tow the motorhome and the other to tow a trailer or the tow vehicle if it is not operational.

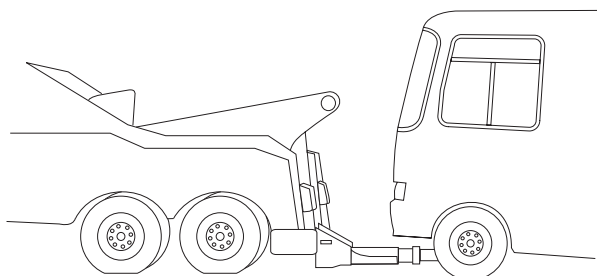

020182

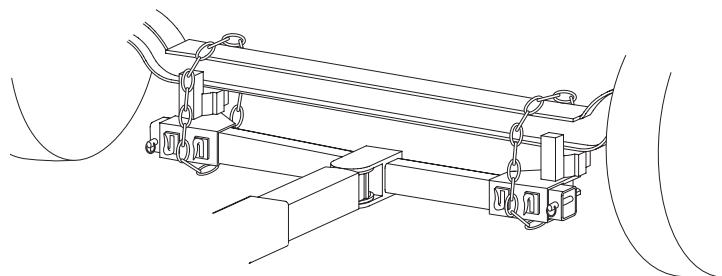

020183

If the motorhome needs to be towed, use the following instructions:

- Secure any loose or protruding parts if the motorhome is damaged.
- Inspect the points of attachment on a disabled motorhome. If attachment points are damaged, select other attachment points at a substantial frame structural member.
- Never allow anyone to go under a motorhome while it is being lifted by towing equipment unless the disabled motorhome is adequately supported by safety stands.
- Do not tow the motorhome from the rear. Towing from the rear will severely overload the front tires and suspension possibly resulting in tire and/or front suspension failure. Rear frame extensions are not designed to support weight loads imposed by lifting the motorhome from the rear.
- If the rear wheels are disabled, place the motorhome on a flat bed trailer or use a heavy duty dolly under the rear wheels and tow the motorhome from the front.
- The drive shaft must be removed to prevent damage to the transmission. Secure the end caps to prevent losing or contaminating the needle bearings.
- The mud flap may need to be removed to prevent damage due to limited ground clearance.



**WARNING: In case the motorhome requires towing, ensure all precautions are followed. The drive shaft must be disconnected and the mud flap may need to be removed. The manufacturer WILL NOT cover damage to the motorhome caused by a towing company.**

## TIRES

The tire designed for the motorhome is a very technical and precisely engineered product. To obtain the maximum wear and best service out of the tires it is helpful to understand the function of a tire. A tire is a “container” that holds air. It is the combination of air and the tire casing that supports the motorhome and its contents. In addition, since the tire is the only contact the motorhome has with the road surface, it must provide other functions such as traction for moving, stopping, steering and providing a cushion for the motorhome.

### **The Importance of Air Pressure**

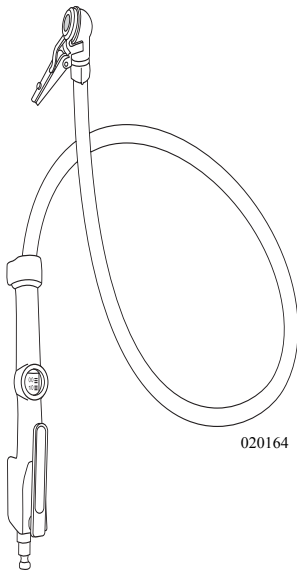

*Remote Inflation Device.*

The most important factor in maximizing the life of the tires is maintaining proper inflation. Driving on any tire that does not have the correct inflation pressure for the load of the motorhome is dangerous and may cause premature wear, tire damage and/or loss of control of the motorhome.

An under-inflated tire will build up excessive heat that may go beyond the design limits of the rubber and radial cords, which could result in sudden failure. An under-inflated tire will also cause poor motorhome handling, rapid and/or irregular tire wear and an increase in rolling resistance that results in a decreased fuel economy.

An over-inflated tire will reduce the tire's footprint/contact patch with the road, thus reducing traction, braking capacity and handling of the motorhome. Over-inflation of a tire for the load will result in a harsh ride, uneven tire wear and is susceptible to impact damage.

Maintaining correct tire inflation pressure for each loaded wheel position on the motorhome is of the utmost importance and must be a part of regular motorhome maintenance.



**WARNING: Driving on a tire that is under-inflated can exceed the design limits of the tire and may damage the sidewall. A damaged sidewall can burst upon inflation resulting in serious damage, injury or death. Aged tires are also susceptible to sidewall damage. For safety purposes clear the area of people and pets during tire inflation. Inflate the tires using a remote inflation device.**

Federal law requires that the specifications for the tire's maximum load rating be molded into the sidewall of the tire. The amount of air pressure to use is dependent on the weight of the motorhome when it is fully loaded. The chart within this section indicates the weights that can be properly supported by varying air pressures. Decreasing air pressure decreases load carrying capacity.

## ***How Much Air Should I Carry in My Tires?***

---

Always comply with the tire manufacturer's recommended pressure inflation guideline. The actual weight of the motorhome can vary significantly depending on how it is loaded. For optimum tire wear, ride and handling always comply with the manufacturer guideline. A tire inflation chart listing proper inflation pressure for different loads is contained in this section of the manual.

## ***Tire Pressure Inflation Guideline***

The tires of the motorhome are inflated to pressure(s) appropriate for the actual weight on each axle in the unloaded, shipped condition. When the motorhome is loaded, check and adjust the inflation pressure on each tire as needed.

Always inflate tires to the pressure indicated in the tire chart for the load carried by the tire. **DO NOT OVERINFLATE OR UNDERINFLATE THE TIRES.**

The Gross Axle Weight Rating (GAWR) of the axles listed on the federal certification label attached to the motorhome is the maximum allowable loaded weight on an axle.

When the actual loaded weight of the motorhome and the weight on each axle is unknown, follow the recommended tire inflation pressure(s) listed on the federal certification label. When loading a motorhome never exceed the motorhome's Gross Vehicle Weight Rating (GVWR) or the GAWR for each axle.

Contact the tire manufacturer for further information concerning proper tire pressure inflation and other tire issues.

## **WEIGHT TERMS**

The **GVWR (Gross Vehicle Weight Rating)** and **GAWR (Gross Axle Weight Rating)** stickers on the motorhome (normally located on the support pillar next to the driver's seat) will show the chassis manufacturer's and/or the RV manufacturer's total vehicle maximum weight ratings and per axle weight rating.

The GVWR is the maximum total weight for which the motorhome is rated – including passengers, fluids and cargo. The GAWR is the maximum for which a single axle is designed. These per axle and total maximum weight ratings could be limited by the tires, wheels, axle and axle bearings, the motorhome frame or other components of the motorhome.

The GAWR sticker is only a guide in knowing the maximum loaded axle weights, and subsequently the correct tire inflation pressure. Every recreational vehicle, even of the same make and model, will vary in actual loaded axle weights because of different options and personal loads.

While the actual loaded axle weight should be below the GAWR, the motorhome must be weighed in a loaded condition to know its actual weight. Weigh the front axle, the total unit and the rear axle. It is possible for a motorhome to be within the GVWR yet overloaded on an axle. It is even possible for one wheel position to be overloaded, even though the GAWR has not been exceeded. For this reason (if there is room to the sides of the scales) weigh each wheel position of the motorhome. This will give a clear indication of exactly how the weight of the motorhome is distributed. These instructions and diagrams are presented on the following pages. When the total weight, and the weight on each axle, is known the tire load data chart in this manual will show the correct cold inflation pressure per tire for each axle.

There are two important factors to consider when loading the motorhome: **total weight** and **balance**. When loading heavy objects keep them as low as possible, preferably on the floor. Load weight must be distributed as evenly as possible. The following is an explanation of commonly used weight abbreviations.



- **Gross Vehicle Weight Rating (GVWR):**

Maximum permissible weight of this motorhome. GVWR is equal to or greater than the sum of UVW plus NCC.

- **Unloaded Vehicle Weight (UVW):**

Weight of this motorhome as built at factory with full fuel, engine oil and coolants. UVW does not include cargo, fresh water, LP-Gas, occupants or dealer installed accessories.

- **Net Carrying Capacity (NCC):**

Maximum weight of all occupants including driver, personal belongings, food, fresh water, LP-Gas, tools, tongue weight of towed vehicle, dealer installed accessories, etc., that can be carried by this motorhome. (NCC is equal to or less than GVWR minus UVW.)

- **Gross Combined Weight Rating (GCWR):**

Value specified by motorhome manufacturer as maximum allowable loaded weight of this motorhome with its towed trailer or towed vehicle.

- **Gross Axle Weight Rating (GAWR):**

The load-carrying capacity specified by manufacturer of a single axle system, as measured at tire ground interfaces.

- **Gross Combined Axle Weight (GCAW):**

The sum of the total weight of all axles when added together.

- **Sleeping Capacity Weight Rating (SCWR):**

Manufacturer's designated number of sleeping positions multiplied by 154 pounds.

## Weight Label

<b>MODEL YEAR:</b> _____	<b>MAKE:</b> _____	<b>MODEL:</b> _____
<b>UNIT NO.</b> _____	<b>CHASSIS VIN:</b> _____	
	<u>LBS.</u>	<u>KGS.</u>
<b>GVWR</b>	(Gross Vehicle Weight Rating) is the maximum permissible weight of this fully loaded motorhome .....	_____
<b>UVW</b>	(Unloaded Vehicle Weight) is the weight of an exemplar Motorhome as manufactured at the factory with full fuel, engine oil and coolants (*1) .....	_____
<b>SCWR</b>	(Sleeping Capacity Weight Rating) is the manufacturer's designated number of sleeping positions multiplied by 154 pounds (70 kilograms) .....	_____
<b>CCC</b>	(Cargo Carrying Capacity) is the GVWR minus each of the following: UVW, full fresh (potable) water weight (including water heater), full LP-Gas weight and SCWR.....	_____
<b>GCWR</b>	(Gross Combination Weight Rating) is the maximum allowable combined weight of this motorhome and the towable product (*2).....	_____
	FACTORY INSTALLED OPTIONS are options installed at the factory but do not include dealer installed after market equipment...	_____
<b>CARGO CARRYING CAPACITY (CCC) COMPUTATION</b>		
GVWR .....	_____	_____
minus UVW .....	_____	_____
minus fresh water (*3) weight of ___ gallons @ 8.3 lbs./gal .....	_____	_____
minus LP-Gas weight of ___ gallons @ 4.5 lbs./gal .....	_____	_____
minus SCWR of ___ persons @ 154 lbs./person.....	_____	_____
CCC for this motorhome (*4) .....	_____	_____
<b>CONSULT OWNER MANUAL(S) FOR SPECIFIC WEIGHING INSTRUCTIONS AND TOWING GUIDELINES.</b>		
<b>WARNING: DO NOT EXCEED THE GVWR, GCWR AND/OR GAWR AFTER LOADING YOUR MOTORHOME WITH WATER, FUEL, PASSENGERS AND CARGO. GAWR (Gross Axle Weight Rating) means the maximum permissible load weight a specific axle is designed to carry. See Federal Certification Label for disclosure of The GAWR for each axle.</b>		
<p>(*1) The UVW has been determined by weighing an exemplar motorhome with some but not all optional equipment available for each model year, make and model of motorhome. The result of the weighing of the exemplar motorhome is then used in calculating the UVW of other motorhomes of same model year, make and model. Your actual UVW may vary based upon options ordered. Please contact the manufacturer for the actual weight of each option.</p> <p>(*2) Consult your Owner's Manual for towing limitations, restrictions and other guidelines.</p> <p>(*3) Your motorhome's fresh water tank and water heater taken together determine the gross fresh water capacity. Your usable fresh water capacity, however, may be less.</p> <p>(*4) Dealer installed equipment and towed vehicle tongue weight will reduce CCC.</p>		
		weight label chart

## WEIGHING THE MOTORHOME

Improperly inflated tires, or suspension that is incorrectly loaded, can result in poor fuel economy, poor handling and over-stressed chassis components. Vehicle loading affects tire inflation pressure and the load carried by each axle. Motorhome axle configuration and floor plan styles will require different weighing procedures.



**WARNING: Improperly inflated or overloaded tires can cause a blowout. An overloaded axle can cause a component failure of the suspension system. Tire blowouts or broken suspension components can lead to loss of vehicle control resulting in property damage, personal injury or death.**



**CAUTION: If actual weight carried by any tire is below the tire chart weight specification a minimum tire pressure of at least 75 psi. must be maintained. Tire pressure below 75 psi. can overheat and damage the tire casing leading to premature tire failure or blowout.**

**Slide-out Tire Pressure:**

A motorhome equipped with slide-out room(s) will weigh slightly heavier on the driver's side. The tire inflation pressure of the driver's side tires determines the inflation pressure for all tire(s) on that axle. This is due to the weight transfer that occurs when cornering. Approximately the same weight load will be transferred to the passenger side around left-hand corners.



**NOTE: When weighing a motorhome equipped with a slide-out room, each tire on any axle must be inflated to the same pressure. The wheel position carrying the most weight will determine the tire inflation pressure for each tire of that particular axle.**

**Scale:**

Certified public scales are located in a variety of places such as moving and storage lots, farm suppliers with grain elevators, gravel pits, recycling companies and large commercial truck stops.

If you are not aware of a nearby public scale, check the local area telephone book yellow pages under “scales-public” section or “weighers.” A nominal fee will be charged, but this is money wisely spent.

Weight scale types and weighing methods will affect the procedure used to determine proper tire inflation pressure and axle loading. The size of some scales will allow the entire motorhome to fit on the scale, which will read the GVW with only one scale recording required. Other scales are designed to weigh only one axle at a time, which may require two or three scale readings to determine the GAW or GVW total. Some scales will read only one wheel position at a time due their physical size. Several scale readings may be required to determine the GAW or GVW total.

Slide-out equipped motorhomes will require each wheel position to be weighed. This is referred to as a four corner weigh. This type of weighing procedure will accurately determine what the correct tire inflation pressure should be. Depending on the type of scale being used, several different scale readings may be required.



**NOTE: The most accurate method to determine proper tire pressure is a four corner weigh. A slide out motorhome will require each tire to be weighed independently. Weighing an axle will net the total weight carried by that axle. When calculating the drive axle dual tire pressure using a independent corner weigh method, divide the total weight by two to determine the weight carried by each tire. When weighing the entire drive axle, divide the total weight by four to determine the approximate weight carried by each tire.**

**Example:**

The motorhome must be weighed fully loaded to obtain accurate scale readings and to determine the proper tire pressure.

- Take the rear axle Gross Axle Weight Rating (GAWR) and divide it by two. Record the figure next to scale B,  $GAWR \div 2$ . Example: If rear axle GAWR is 13,000 lbs.  $GAWR \div 2$  would be 6,500 lbs.
- Weigh the driver's side rear corner (scale B) and record the scale reading next to Gross Axle Weight (GAW) for scale B. Example: Scale B reading is 5,100 lbs.
- Repeat procedure for the rest of the scale readings.
- Add the GAWR from scales B and D and enter the sum next to the final GAWR. Example: 13,000.
- Add the GAW from scales B and D and enter this sum next to the final GCAW. Example: 10,000.
- Compare scale readings GCAW against GAWR readings. All figures on line 2 are not to exceed figures on line 1.
- Use tire chart with scale reading to determine correct tire pressure.



**NOTE: Scale readings and Gross Axle Weight Ratings are fictitious. Actual scale readings and Gross Axle Weight Ratings will vary with model and options.**

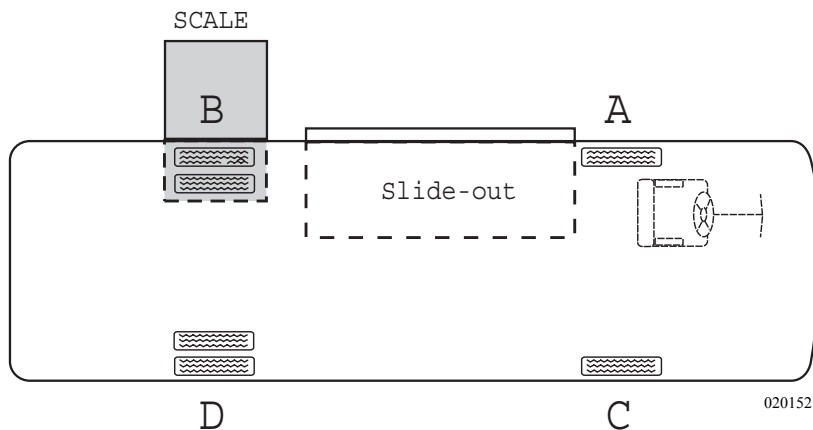

**Rear**

<b>Scale</b>	<u>1. GAWR <math>\div</math> 2 (6,500)</u>			
<b>B</b>	<u>2. GAW (5100)</u>			
	+		=	
				<u>1. GAWR (13,000)</u>
				<u>2. GCAW (10,000)</u>
 <b>Scale</b>	 <u>1. GAWR <math>\div</math> 2 (6,500)</u>			
<b>D</b>	<u>2. GAW (4,900)</u>			

**Weighing a two axle non-slide motorhome.**

- Record the Gross Axle Weight Ratings (GAWR) and the Gross Vehicle Weight Rating (GVWR).
- Weigh and record each wheel position or total axle weight.
- If necessary, adjust the payload so the GAWR is not exceeded. Total combined weights must not exceed the GVWR.
- Using the tire chart, locate the recommended air pressure for the weight carried by each tire. Adjust the tire pressure accordingly.

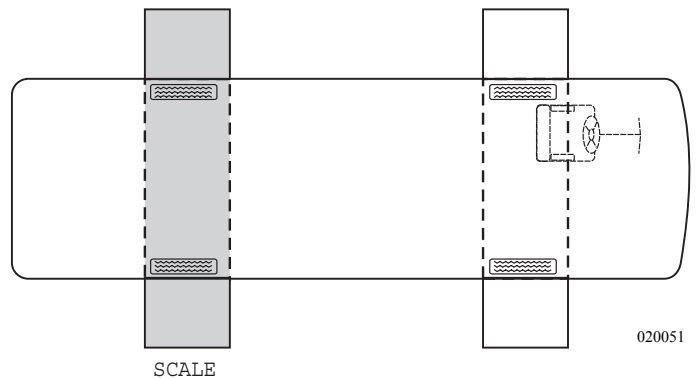

$$\underline{\text{GAWR (Rear)}} + \underline{\text{GAWR (Front)}} = \underline{\text{GCVW}}$$

$$\underline{\text{GAW (Rear)}} + \underline{\text{GAW (Front)}} = \underline{\text{GCAW}}$$

**Weighing a two axle slide-out motorhome.**

- Slide rooms must be in the retracted position.
- Record the Gross Axle Weight Ratings (GAWR) and the Gross Vehicle Weight Rating (GVWR).
- Weigh and record the weight placed on each tire.
- If necessary, adjust the payload so the GAWR is not exceeded. Total combined weights must not exceed the GVWR.
- Using the tire chart, locate the recommended air pressure for the weight carried by each tire. Adjust the tire pressure accordingly.

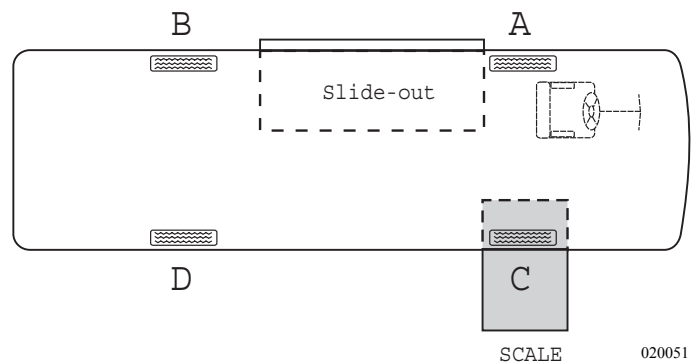

<b>Rear</b>		<b>Front</b>	
Scale B	$\frac{\text{GAWR} \div 2}{\text{GAW}}$	Scale A	$\frac{\text{GAWR} \div 2}{\text{GAW}}$
+	=	+	=
	$\frac{\text{GAWR}}{\text{GCAW}}$		$\frac{\text{GAWR}}{\text{GCAW}}$

Scale D	$\frac{\text{GAWR} \div 2}{\text{GAW}}$	Scale C	$\frac{\text{GAWR} \div 2}{\text{GAW}}$
---------	---	---------	---

## TIRE CHART

TIRE SIZE	psi	60	65	70	75	80	85	90	95	100	105	110	115	120	125
275/70R22.5	D			3880	4100	4320	4535	4745	4960	5165	5370	5575	5775	5975	6175(H)
	S			4160	4395	4630	4860	5085	5310	5535	5755	5970	6185	6400	6615(H)

*The motorhome manufacturer is not the author of this chart and makes no representation or warranty concerning the accuracy of the information disclosed by the chart. The motorhome manufacturer is not responsible for the accuracy of the information disclosed or for any errors within the Tire Inflation Chart.*

### Inspecting & Pressure

Regularly check the tire pressure. A nail or screw can lodge in a tire and create a slow leak. The object may eventually be spotted on a front tire or an outside rear dual. However, if there is a slow leak on an inside dual, it will probably go unnoticed. If you begin driving unaware that an inside dual tire is low on air pressure or is flat, very quickly (in most cases a few miles) the outside rear tire will heat up due to carrying double the load. This can lead to failure of the outside tire resulting in two flat tires on the same side of the same axle.

Check the tire pressure every two weeks or at least once a month and before any major trip. Check the tire pressure every "drive" morning on both long and short trips (driving a day or less). Check the tire pressure before leaving on a trip and again before starting your trip home. Check the tire pressure before storing the motorhome for any length of time. More importantly, check the tire pressure when removing the motorhome from storage.

Check the tire pressure when the tires are "cold" and have not been driven for more than one mile. The rated load capacity for cold inflation pressure is based on ambient temperature. If you must check the tires when they are warm or hot, allow for a slight increase in air pressure. The pressure should be within a couple of pounds of each other on the same axle. Never let air out of a hot tire.

When checking the inflation pressure, use a high-quality truck tire air gauge. These have an angle dual head. This type of pressure gauge can check the pressure of the inner dual wheel that has the valve stem pointing outward and the outer wheel has the valve stem pointing inward. Nothing should restrict the ability to easily check the tire's air pressure daily when traveling in the motorhome. Use valve stem caps with a positive seal to prevent air escaping from the valve stem. If there are extension hoses on the valve stem, make sure they are good quality reinforced stainless steel braid. Attach hoses securely to the outer wheel.

Optimum tire performance is achieved at proper inflation pressure for the load carried. Do not mix tires of different tread patterns on the same axle. The difference in traction could cause rear end gear fight and mechanical damage to the drive train. Never mix tires of a different size or construction on the same axle.

**Higher than recommended pressure can cause:**

- Hard ride.
- Tire bruising or carcass damage.
- Rapid tread wear in the center of the tire.



**WARNING: Improperly inflated tires can effect handling or cause sudden tire failure possibly resulting in loss of vehicle control. Always use an accurate tire pressure gauge when checking tire pressure.**

**Lower than recommended pressure can cause:**

- Tire squeal on turns.
- Rapid and uneven wear on the edges of the tread.
- Tire rim bruises and rupture.
- Tire cord breakage.
- Excessive tire temperature.
- Reduced handling quality.
- High fuel consumption.

**Unequal tire pressures on same axle can cause:**

- Uneven braking, swerve upon acceleration.
- Steering lead, torque steer.
- Reduced handling quality.



**WARNING: Driving on a tire with low air pressure can exceed the design limits of the tire. Damage to the sidewall of the tire can occur. A damaged sidewall can burst upon inflation causing serious damage, injury or death. Aged tires are also susceptible to sidewall damage. For safety purposes clear the area of people and pets during tire inflation. Inflate tires using a remote inflation device.**

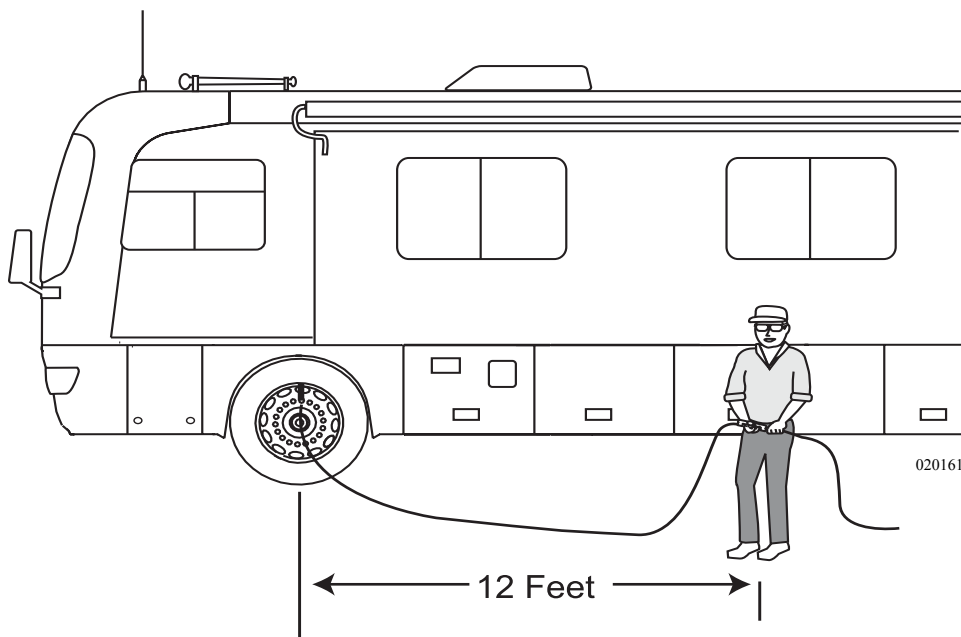

## Tire Vibration

Sudden tire failure or blowout is often preceded by tire vibration. Some other symptoms that can cause tire failure are a bulge in the sidewall or swelling in the tire carcass. Striking an object or large hole in the road surface can damage a tire. Inspect the tires immediately after such an occurrence. Continue to inspect the tires periodically thereafter in case minor damage occurred. Rotation forces can continue to stress damaged areas that can manifest later in a sudden tire failure. If an unusual vibration begins, or a bulge is noticed in a sidewall, have the tires evaluated by a qualified professional as soon as possible.

## Tire Rotation

Tire rotation can increase the useful life of the tires by achieving uniform wear on all of the tires. The first tire rotation is the most important. Have the tire manufacturer determine the tire rotation pattern. Any unusual or unique wear pattern that may have developed should be evaluated before rotation. Misalignment, imbalance or other mechanical problems may exist and will need corrected prior to rotation.

The tire rotation should be performed if there is any sign of uneven wear. After a tire rotation, check and adjust the inflation pressures for the actual loads of the wheel position accordingly.

Tires are warranted by the tire manufacturer. The motorhome manufacturer is not responsible for warranty coverage or tire wear.

## Tires - Supporting When Leveling

### Tire "Support" Methods

#### INCORRECT

##### Singles

Only a portion of the tire is supporting the full load.

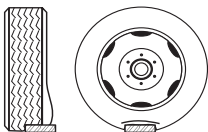

#### CORRECT

##### Singles

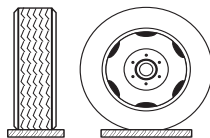

Tire Footprints



##### Duals

• One tire or a portion of one tire is supporting the full load.

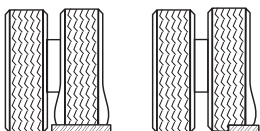

##### Duals

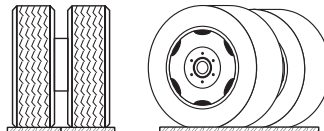

Dual Tire Footprints

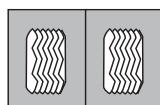

020063B

Extreme caution must be taken to ensure that the tires are fully supported when placing blocks under the tires. The load on the tire should be evenly distributed on the support block. In the case of dual tires, distribute the load evenly on blocks for both tires. If not properly supported, the steel cables in the sidewall of the tires may be damaged and could lead to premature fatigue of the sidewall.



**CAUTION: Supporting the tires prevents damage to the sidewall of the tires and does not prevent tire roll.**

#### Proper Cleaning:

Road oil will cause deterioration of the rubber. Dirt buildup will help hold chemicals in the air next to the tire and will also cause deterioration.



When cleaning any rubber product, proper care and methods in cleaning must be used to obtain the maximum service years out of the tires. Use a soft brush and a mild detergent to clean the tires. If a dressing product is used to “protect” the tires from aging, use extra care and caution. Tire dressings that contain petroleum products or alcohol may cause deterioration or cracking.

In many cases it is not the dressing that causes a problem but the chemical reaction that subsequently occurs. When these same dressing products are used on a passenger car tire that is replaced every three to four years, it is rare to see a major problem. However, in most cases, RV tires may last longer due to limited annual mileage and exposure.

---

The recreational vehicle is designed for recreation not long-term storage. However, unless you are living in your motorhome full-time you will have a need to store it. Rubber tires age faster when not being used. A cool, dry, sealed garage is the preferred method of storage. Many recreational vehicles are stored outside in the elements. Some storage surfaces may cause tires to age prematurely. Placing a barrier (i.e. cardboard, plastic or plywood) between the tire and the storage floor/ground surface will help to protect the tires.

### ***Storage of Tires - Long Term***

There are a few steps that can be taken to reduce the aging effects from long-term storage or a non-use period. Thoroughly clean the tires. Cover the tires to block direct sunlight and ultraviolet rays. Store the recreational vehicle out of a high ozone area. Failure to take these steps can cause early deterioration and shorten the life of the tires.



**NOTE: When the motorhome is stored the tires should be inflated to maximum inflation pressure as indicated on the sidewall of the tire.**

Before removing the motorhome from long-term storage thoroughly inspect each of the tires. This means a close examination of each tire’s tread area and air pressure. If the pressure check indicates the tires have lost air during storage, inflate them to the correct pressure for the current load before putting the motorhome into service.

---

In the event of a flat tire, it is recommended to call for roadside assistance. The size and weight of the motorhome and its tires require the proper equipment to change the tire. A professional service technician will have the equipment and training needed to repair or replace the tire. In the case of sudden tire failure, avoid heavy braking. Hold the steering wheel firmly and gradually decrease speed. Slowly move to a safe off-road place, which should be a firm level spot. Turn the ignition off and turn the hazard flasher system ON. Save the old tire for any warranty coverage.

### ***In Case of Flat Tire***

For used nuts: Add 2 drops of oil between Flange & Hex.

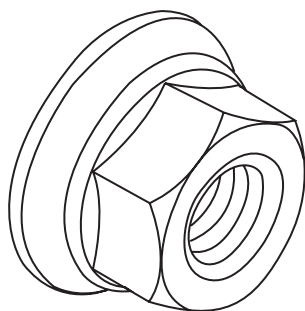
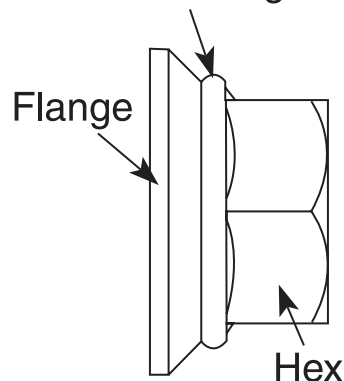

090268

### Hub Piloted Mounting:

- Before using flange nuts that have already been used in service, apply two drops of oil at one point between the flange and hex. This will allow parts to rotate freely and provide the proper clamping force when tightened. Use any common lubricant typically used for fasteners. Examples are motor oil and general purpose lubricating oils. Excessive lubricant is not desirable, this will not improve the nut torquing performance. Excessive lubricant makes the nuts hard to handle, attracts dirt to the nuts and may cause unsightly appearance to the wheel. Only used nuts need to be lubricated.
- Since flange nuts generate higher clamping force always use grade eight studs with hub mount wheels.
- Before installing the wheels, lubricate the hub pilot pads with a drop of oil to prevent galling. Do not lubricate any other wheel or hub surface.
- For a hub with intermittent pilot pads, position a pad at the twelve o'clock position to center the wheel and reduce runout.



**NOTE: Loosen and tighten lug nuts in a star pattern sequence. Sequence tighten to 50 ft. lbs. first, then sequence tighten to 500 lbs. Over-tightening can cause distortion.**



**WARNING: Never use wheels or lug nuts different than the original equipment as this could damage the wheel or the mounting system. Damage to the wheel or mounting system could cause a wheel to come off while the recreational vehicle is in motion.**

**Front Wheels:**

Slide the front wheel over the studs, being careful not to damage stud threads. Snug the nuts in sequence, do not tighten them fully until all have been seated. Tighten the nuts to 500 ft.lbs in sequence (as shown in the illustration).

**Dual Rear Wheels:**

Slide the inner dual wheel over the studs, being careful not to damage the stud threads. Align the handholds for valve access and slide the outer dual wheel over the studs, again being careful not to damage the stud threads.

Snug the nuts in sequence, do not tighten them fully until all have been seated. Tighten the nuts to 500 ft. lbs. using the sequence (as shown in the illustration). The hub mount wheels use two piece flange cap nuts for both front and rear applications. No inner cap nuts are required.

**Torque the Nuts Properly:**

- Tighten the wheel nuts to the recommended lug nut torque. Do not over tighten.
- Maintain the nut torque at the recommended level through planned periodic checks or at 10,000 miles intervals, whichever comes first.
- If air wrenches are used they must be periodically calibrated for the proper torque output. Use a torque wrench to check the air wrench output and adjust the line pressure for the correct torque.

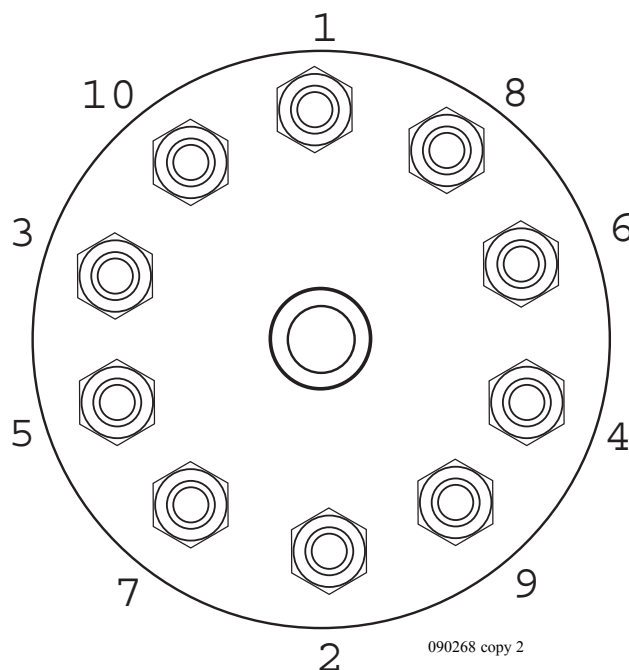

**Nut Tightening Sequence**

## VIEWS - Front

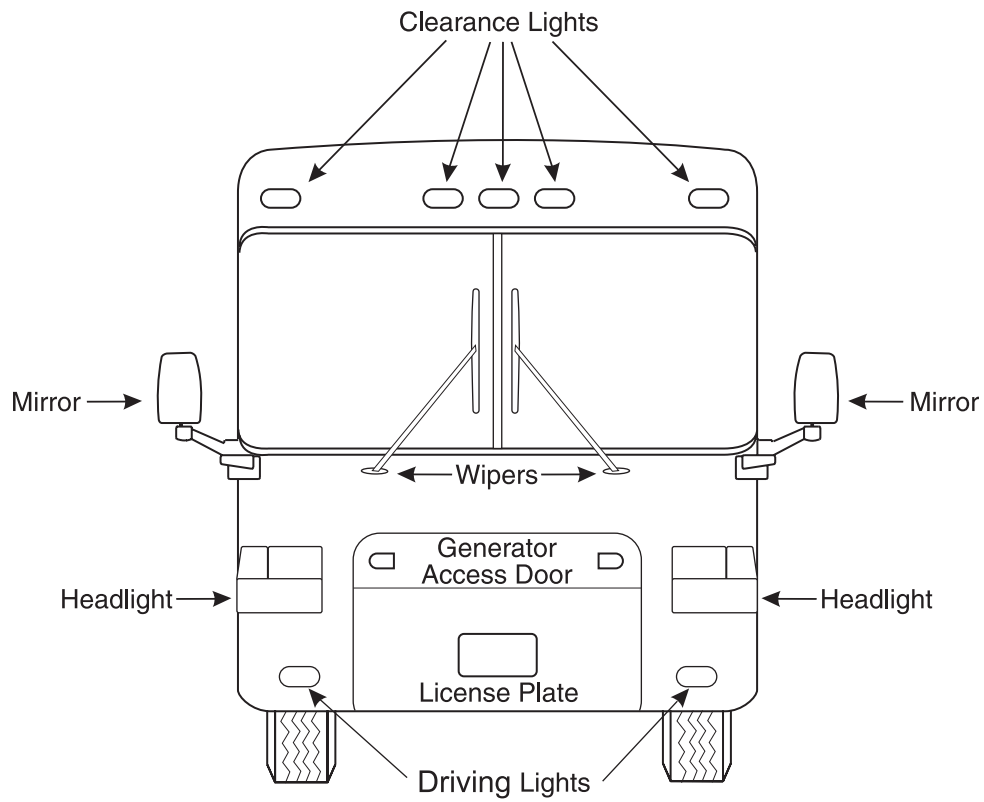

## Rear

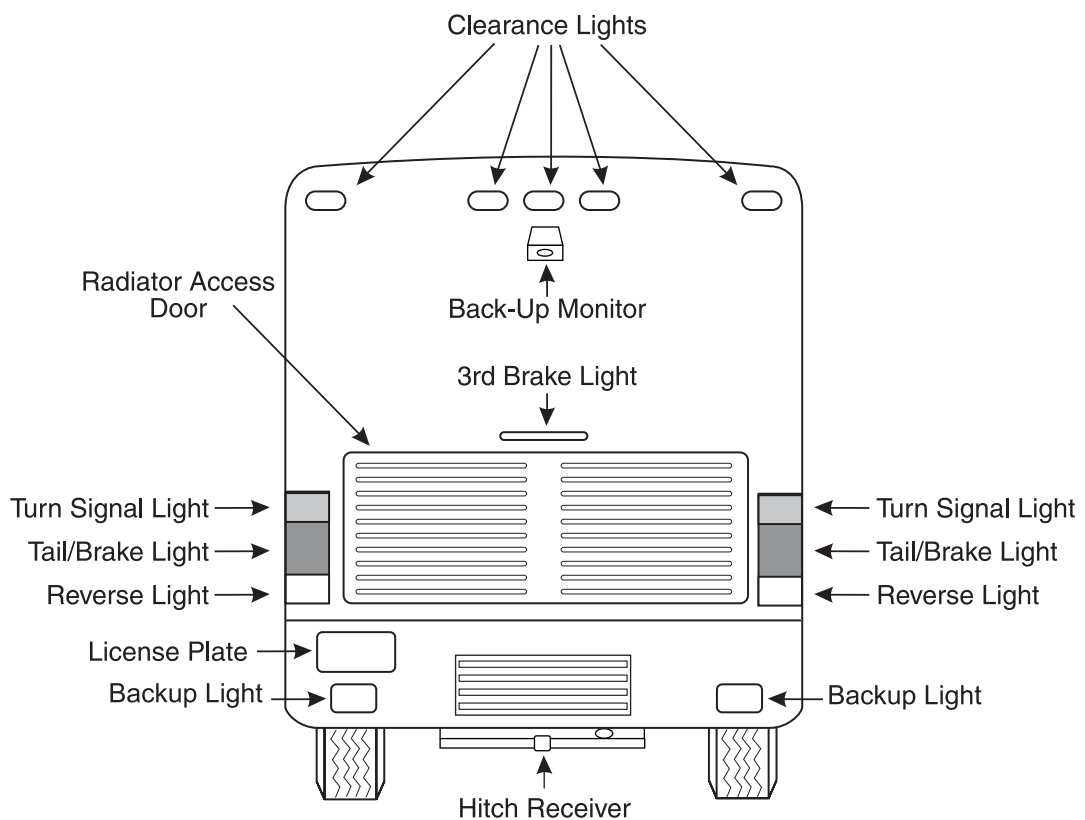

**Roadside**

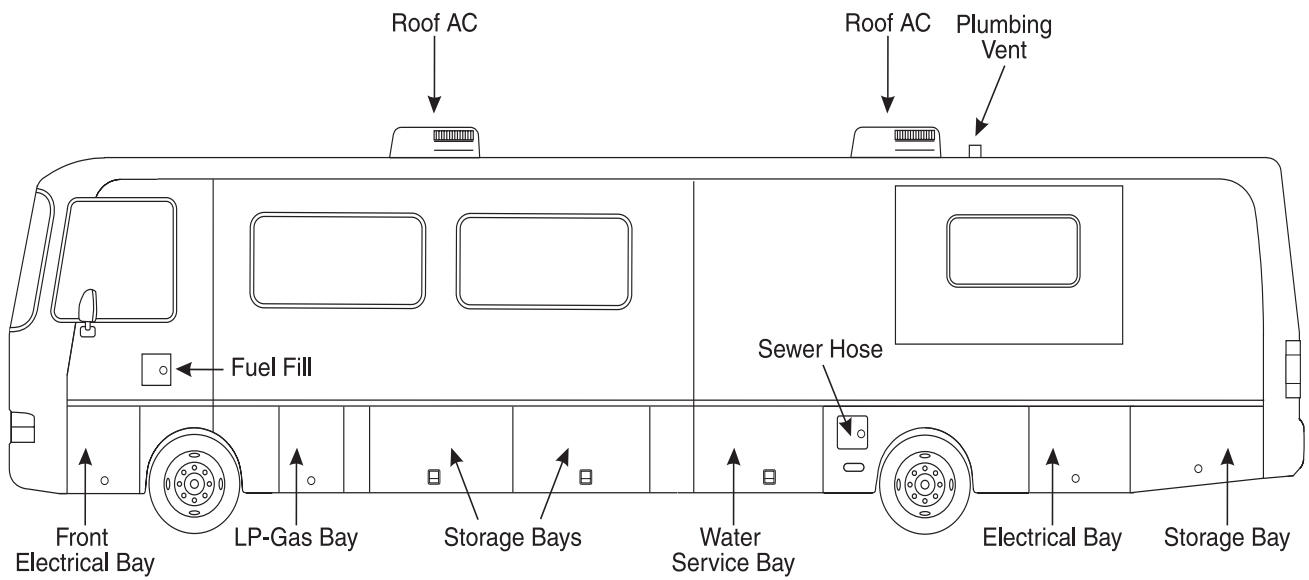

**Curbside**

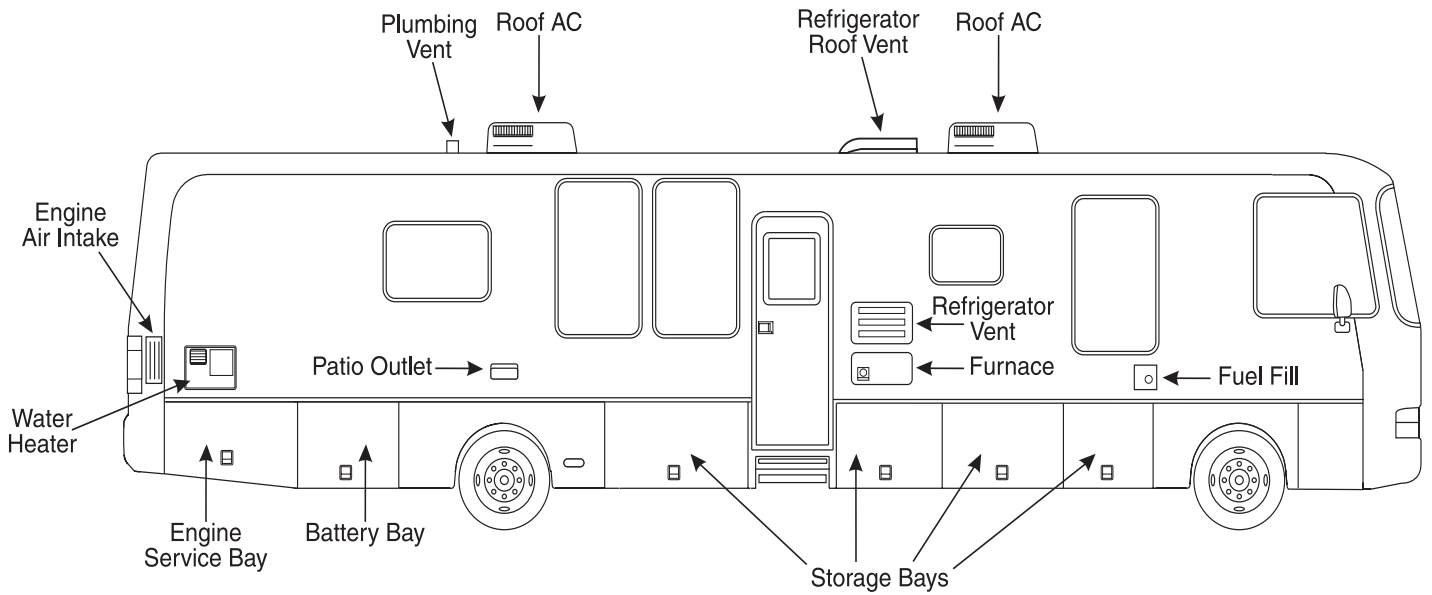

**SPECIFICATIONS -  
DIMENSIONS  
CHART**

MODELS	3996	3756
Wheelbase	262 1/4"	TBA
Overall Length	40' 1"	TBA
Overall Height with A/C*	11' 8"	TBA
Interior Height	77 1/8"	TBA
Interior Width	97 1/2"	TBA
Exterior Width	101 3/4"	TBA



**NOTE:** This chart reflects product specifications available at the time of printing. Therefore any floor plans introduced thereafter may not be reflected in the chart. All other information contained throughout the manual will still apply.

**SMOKE DETECTOR**

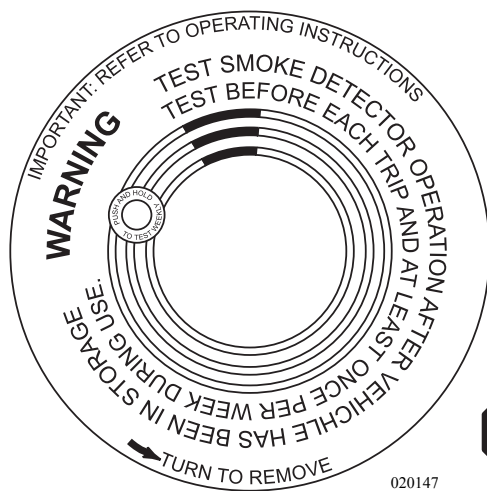

Statistics show that most fire casualties are not caused by direct flame, but by less visible smoke (products of combustion). The smoke detector responds to both visible and invisible products of combustion. The smoke detector will automatically return from alarm to normal state when the reason for activation, the presence of smoke, is completely removed. Fires are commonly caused by smoking in bed, leaving children unattended or using flammable cleaning fluids. Please be safety conscious and avoid unnecessary risk.



**WARNING:** There is no way to insure there will be no injury or loss of life in a fire; however, the smoke detector is intended to help reduce the risk of tragedy. Additional smoke detectors may help to reduce the risk. Proper use and care of the smoke detector could save lives.

**Operation**

When a 9 Volt DC battery is correctly connected, the smoke alarm is operating. The LED will flash every minute showing the battery is supplying power. A load alarm will sound when a production of combustion is sensed.



**NOTE:** The unit will not operate without a battery. A battery flag will pop up preventing the unit from being installed to the mounting bracket without a battery. Carbon zinc batteries average a service life of one year. Alkaline batteries average a service life of one to two years.

## **How to Test**

Simply press the test button on the smoke alarm cover for approximately three seconds. The alarm will sound if all electronic circuitry, horn and battery are working properly. The smoke alarm should be tested at least once a week when the motorhome is in use, prior to each trip and when the motorhome has been in storage. When testing the smoke alarm it is advised to stand at arms length.



**CAUTION: Never use an open flame to test the smoke alarm. You may ignite and set fire to the alarm and to the motorhome.**

A smoke alarm is designed to be as maintenance free as possible. However, there are some simple steps to perform in order to keep the smoke alarm working properly:

## **Maintenance**

- Test the smoke alarm once a week.
- Keep a supply of 9 Volt DC batteries on hand.
- Vacuum the slots in the cover and sides with a soft brush attachment every month. Test the smoke alarm once the unit has been vacuumed.
- The smoke alarm should be cleaned every six months to help keep the unit working efficiently.
- The smoke alarm will beep once a minute when a low battery condition exists. The battery must be replaced immediately.

If the alarm does not sound when the test button is pushed, or with a smoke test, try the following:

## **Troubleshooting**

- Inspect for obvious damage.
- Check for the recommended battery type.
- Check the battery for proper connection or replace the battery if needed.
- Gently vacuum as recommended.

If these procedures do not correct the problem, do not attempt repairs. If the smoke alarm is within the warranty period and the terms indicate the nature of the problem, return the unit to your dealer. Smoke detectors beyond the warranty period cannot be economically repaired.

## LP-GAS DETECTOR

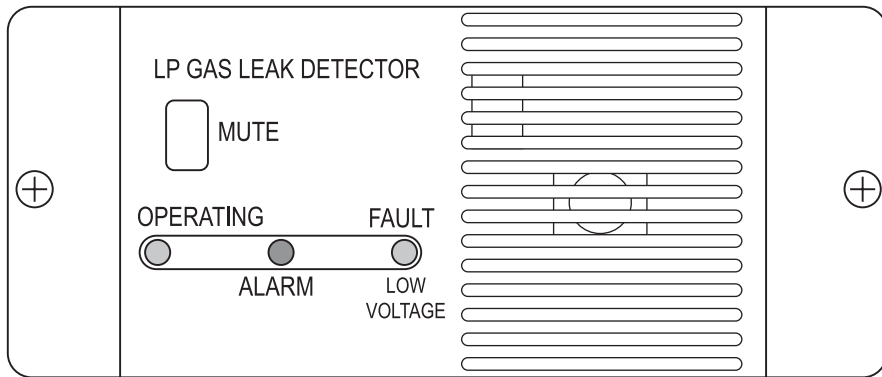

050258

The LP-Gas detector is provided for safety. It detects both LP-Gas and methane gas. Liquefied Petroleum (LP) Gas is heavier than air; methane gas is lighter than air. LP-Gas will settle to the lowest point, generally the floor of the motorhome. Methane gas will rise. The gas detector is also sensitive to other fumes such as hair spray, of which most contain butane as the propellant.

Butane, like propane, is heavier than air and will settle to the floor level where it will be detected. When this occurs, press reset button to stop the alert sound for 60 seconds.

Other combustibles which will be detected include alcohol, liquor, deodorants, colognes, perfumes, wine, adhesives, lacquer, kerosene, gasoline, glues, most cleaning agents and propellant of aerosol cans. Most are lighter than air in their vapor state and will only be detected when the motorhome is closed up.

Upon first application of power the LED will flash **yellow** for three minutes while the detector is stabilizing. At the end of the start cycle the LED will turn **Green**, indicating full operation. If the detector senses unsafe levels of gas it will immediately sound an alarm. The gas detector operates on 12 Volt DC, with a current draw less than 1/10th of one amp.



**CAUTION: The detector will not alarm during the three minute warm up cycle.**

### Testing

Press the **TEST** switch any time during the warm up cycle or while in normal operation. The LED should flash **red** and the alarm should sound. Release the switch. This is the only way the detector should be tested. The test feature checks full operation of the detector.



**WARNING: Test the operation of this detector after the motorhome has been in storage, before each trip and at least once per week during use.**



**Alarm**

The **red** LED will flash and the alarm will sound whenever a dangerous level of propane or methane gas is detected. The detector will continue to alarm until the gas clears or the **TEST/MUTE** switch is pressed.

**Procedures To Take During An Alarm:**

1. Turn off all gas appliances, (stove, heaters, furnace), extinguish all flames and smoking material. Evacuate, leave doors and windows open.
2. Turn off the propane tank valve.
3. Determine and repair the source of the leak. Seek professional help if necessary.



**CAUTION: Do Not re-enter until the problem is corrected.**

**Alarm Mute:**

Press the **Test-Mute** button when the detector is in alarm.

1. The **red** LED will continue flash and the alarm will beep every 30 seconds until the gas level has dropped to a safe level.
2. The LED will flash **green** until the end of the **MUTE** cycle.
3. If dangerous gas levels return before the end of the **MUTE** cycle, the alarm will beep four times and return to phase 1.
4. After two minutes the detector will return to normal operation (**solid green**) or resound the alarm if dangerous levels of gas remain in the area.

**Fault Alarm:**

Should the microprocessor sense a fault in the gas detector, a fault alarm will sound twice every 15 seconds. The LED will alternately flash **red** to **green** and the **MUTE** switch will not respond to any command. The gas detector must be repaired or replaced.

1. Vacuum the dust off the detector cover weekly (more frequently in dusty locations) using the soft brush attachment of the vacuum.
2. Do not spray cleaning agents or waxes directly onto the front panel. This action may damage the sensor, cause an alarm or cause a detector malfunction.

**Cleaning**

## CARBON MONOXIDE DETECTOR

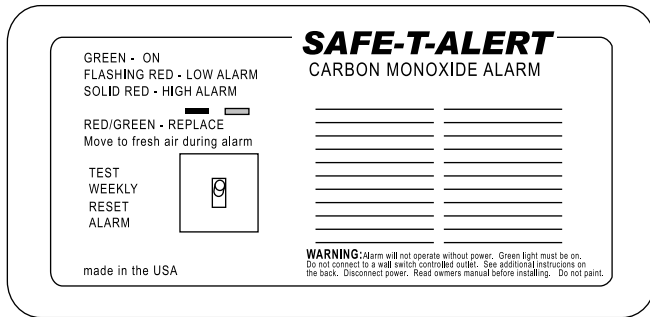

The motorhome is equipped with a carbon monoxide detector. Carbon monoxide (CO) is a colorless, odorless and tasteless gas. Even low levels of CO have been known to cause brain and other vital organ damage in unborn infants, with no effect on the mother. In cases of mild exposure the symptoms may include: a slight headache, nausea, vomiting and fatigue. Symptoms for medium exposure may include a severe throbbing headache, drowsiness, confusion and fast heart rate.

Extreme exposure can result in unconsciousness, convulsions, cardio-respiratory failure and death. Young children and household pets may be the first affected. The CO detector is designed to detect the toxic CO fumes that result from vehicle exhaust and incomplete combustion sources like a furnace, gas stove or water heater. Consequently, it is uncommon for household smoke from cigarettes or normal cooking to cause the alarm to sound.



**NOTE: Activation of this device indicates the presence of carbon monoxide (CO) which can be fatal. A concentration of above 100 PPM will cause a warning condition. Individuals with medical problems may consider using detection devices with lower carbon monoxide alarming capabilities. Prolonged exposure to the horn at a close distance may be harmful to your hearing.**

### Operating Instructions

The detector is equipped with a self-cleaning CO sensor and requires a ten minute initial warm-up period to clean the sensor element and achieve stabilization. The green power light should be lit when the power is on. If the light is not lit, turn off the power and check all wire connections. If the power is on and the connections are correct but the indicator still does not light, the detector should be returned for service. Do not attempt to fix the detector. The indicator light displays a specific color to monitor the conditions as follows:

- **Green** - Indicates **ON** or normal condition. The CO detector has power and is sensing air for the presence of CO gas. The alarm horn will not sound.
- **Yellow** - Indicates a “trouble” or malfunction condition. The alarm horn will sound and cannot be reset by the **TEST/RESET** button. The CO detector is not working properly and must be immediately replaced or repaired.
- **Red** - Indicates an “alarm condition.” The detector has sensed the presence of a hazardous level of carbon monoxide. The alarm horn will sound continuously until the **RESET** switch is reset.

**Alarm**

When the alarm sounds have the detector and the motorhome checked by an authorized service technician as soon as possible. Never disconnect a CO detector to silence an annoying alarm. Evacuate the motorhome immediately when the RED light is lit and the alarm sounds. Do a head count to check that all persons are accounted for. Call the nearest fire department and ask them to determine the source of the carbon monoxide. Do not re-enter the motorhome until it has been aired out and the problem corrected.

**Testing**

Test the carbon monoxide detector operation after the motorhome has been in storage, before each trip and at least once a week during use. Test the alarm by holding the test button in until the alarm sounds. The alarm will stop beeping in about 30 seconds.

**Cleaning**

Use a vacuum cleaner to remove dust or any other buildup on the detector. Do not wash. Wipe the detector with a damp cloth and dry it with a towel. Do not open the detector for cleaning. Do not paint the detector. It is recommend that the carbon monoxide detector be replaced every 10 years.

The fire extinguisher in the motorhome is located near the main entrance door. Please read the operating instructions that are printed on the fire extinguisher. If there is any doubt on how to operate the fire extinguisher, you and your family should practice using it. Be sure to replace or recharge the extinguisher immediately after use.

Inspect the fire extinguisher at least once a month. Do so more frequently if the extinguisher is exposed to weather or possible tampering. Do not test the extinguisher by partially discharging, this will cause a loss of pressure.

**Use the PASS word!**

**Pull** the pin to unlock the extinguisher.

**Aim** at the base (bottom) of the fire and stand 6-10 feet away.

**Squeeze** the lever to discharge the agent.

**Sweep** the spray from left to right until totally extinguished.

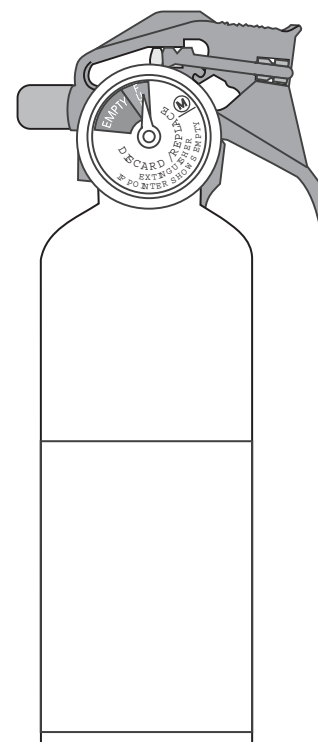
**FIRE  
EXTINGUISHER**

020073

## EGRESS EXIT WINDOW



egress.tif

An egress window is designated for use as an exit in the case of an emergency. Inside the motorhome the egress window is easily identified by the red locking handle. It is also marked as an "EXIT." The glass slider in the egress window operates the same as all other windows.

### To open the egress window:

- Rotate the red handle downward. Slide the window open.
- Slide the window closed and rotate the handle to lock the egress window.



**CAUTION:** The egress window should be opened twice a year to ensure proper operation. Over time, the rubber seal will tend to stick to the egress window. Occasional operation will help prevent the rubber seal from sticking.

# SAHARA

## SECTION 3 CARE & MAINTENANCE

<b>EXTERIOR CARE •</b>	<b>79</b>
<i>Corrosion •</i>	79
<i>Washing •</i>	79
<i>Drying •</i>	80
<i>Waxing •</i>	80
<i>Tire Care •</i>	81
<i>Care &amp; Maintenance of Aluminum Wheels •</i>	81
<i>Bright Metal •</i>	82
<i>Maintenance - Exterior •</i>	82
<i>Roof Care &amp; Seal Inspections •</i>	83
<b>INTERIOR CARE •</b>	<b>84</b>
<i>Fabrics •</i>	84
<i>Fabric Specifications Charts •</i>	87
<i>Vinyl •</i>	90
<i>Leather •</i>	92
<i>Ultra-Leather •</i>	93
<i>Floors - Carpet Cleaning •</i>	94
<i>Floors - Laminate •</i>	95
<i>Shower - Cleaning •</i>	96
<i>Ceilings •</i>	96
<i>Wall Coverings •</i>	96
<i>Wood Care •</i>	98
<i>Countertops •</i>	100
<i>Windows •</i>	101
<i>Mold &amp; Mildew •</i>	102
<i>Mini-Blinds •</i>	103
<i>Day/Night Shades (Bedroom) •</i>	104
<b>STORAGE - Short Term •</b>	<b>104</b>
<b>STORAGE - Long Term •</b>	<b>105</b>
<b>CHECKLIST - Winter Storage •</b>	<b>108</b>
<b>STORAGE - Removal •</b>	<b>108</b>



**EXTERIOR CARE**  
**Corrosion**

The most common cause of corrosion to the motorhome is the accumulation of road salts, grime and dirt. These elements, combined with moisture, may possibly cause early component failure. Salt air and fog from coastal trips can greatly accelerate the corrosion process. Corrosive materials collected from roadways accumulate on the undercarriage, around wheel openings and on the radiator charge air cooler package. These areas need to be cleaned periodically to help prevent component failure due to corrosion. If the motorhome is driven in areas where road salts are used it should be washed at least once a week. Otherwise, it is recommended to hose off the undercarriage area at least once a month to help minimize the corrosion process. High pressure washers or steam cleaners are the most effective way of cleaning off the underside and inside wheel openings. **Avoid directly spraying the painted surface with a high pressure washer.** Remove road debris and mud that has accumulated. Material left behind can intensify the corrosion problem.



**CAUTION: Exercise caution when cleaning the radiator charge air cooler package. Damage to the fins can result when using a high pressure washer or steam cleaner. Nozzle discharge pressure can exceed 1,800 psi. Avoid using high pressure steam cleaners on the exterior paint surfaces. Remove all spattered washing debris from the exterior paint surfaces as soon as possible.**

The life of the exterior paint finish can be extended if properly cared for. Periodic cleaning will help preserve the paint finish. The motorhome is painted with a “base coat, clear coat system.” The clear coat is a polyurethane based material which brings out the shine or luster to the base coat paint. Care should be used when washing the motorhome. Use only mild detergents or preferred specifically designed automotive detergents. Avoid using abrasive cleansers or laundry detergents as they will scratch the clear coat and leave a soap film. The use of specially designed automotive washing utensils, such as soft bristle brushes, are acceptable as long as they do not trap abrasive material and scratch the surface while being used. Before washing the motorhome remove most of the accumulated dirt and “road wash” behind wheel openings, below the windshield and on the rear of the motorhome. If the build up is excessive, run water over a soft brush while gently scrubbing the surface in one direction. This will help float away the “build-up” from the clear coat. Avoid back and forth or circular motions as this may act like sandpaper, scratching the clear coat and leaving a haze or “swirl marks.” After removing the heavy build-up, use the mixed detergent solution to wash the motorhome. Start washing at the top of the motorhome working towards the bottom. If possible, wash the motorhome in a shaded area when the exterior is not hot to the touch. If necessary, turn the motorhome around to keep the area being washed in the shade. Try not to allow the detergent to dry onto the clear coat surface. Use plenty of water when rinsing the surface to remove any detergent residue.

**Washing**

## Drying

Drying chamois cloths come in natural and synthetic materials. Either type is acceptable as long as the surface is clean. Soak the chamois in clean water until all chamois material has absorbed water. Wring excess water from chamois. Start at the top and work towards the bottom. Use a downward “S” pattern to remove water from the surface and wring out the chamois as needed. Using a chamois cloth to remove the rinse water is not necessary, but the effort can be worthwhile.

---

## Waxing

To wax or not to wax? This is a good question. There are many schools of thought on this issue. The two most common thoughts are:

- The clear coat needs to “breathe.” A layer of wax will seal the clear coat not allowing it to breathe, possibly leading to failure of the clear coat.
- If the surface is not waxed, what is protecting the surface from the environment (road salts, acid rain, road tar, ultraviolet light)?

It is recommended to wax the motorhome twice a year: spring and fall. Many types of protective barriers are available today that may be applied to the clear coat: glazes, waxes, polishes, rubbing compounds or combinations of these products.



**NOTE: When selecting a product for use follow the product manufacturer’s recommended application instructions.**

### Types of Products:

**Glazes:** Glazes are generally used to fill very fine scratches in the clear coat, being applied either by hand or by using a polisher with a special pad.

**Waxes:** Waxes come in many types of chemical make-ups. The popular Carnauba wax is a natural occurring wax from the leaves or fronds of the Carnauba palm tree. Mineral waxes have a paraffin base. There are also other topical application products which contain silicone.

**Polishes:** Polishes usually contain a combination of wax based substances with an abrasive, getting the two for one idea. These products can be too abrasive for clear coats and are not recommended for use.

**Rubbing Compounds:** These types of products are generally applied by using a buffer. The use of rubbing compounds should be left to professionals as undesired results can quickly occur. These types of products are generally used to correct or flatten a surface by removing high spots or small amounts of material.

When selecting a product the container should be marked, “safe for clear coats” or “clear coat safe.” Carefully follow all manufacturer’s application instructions when using a product. Upon first use of a product, try it on a “small test spot” in an inconspicuous area in case an undesired reaction occurs.



Observe the test area from different angles checking for hazing or swirl marks. If an abnormal reaction to the finish occurs, discontinue product use and consult the product's manufacturer. If the product is a paste, do not allow dried paste to be baked on by the sun. Remove paste shortly after drying. Clean, dry, 100% cotton cloths or cotton baby diapers are best suited for the removal of dried paste. Turn the cloth often. Use a separate clean cloth to buff. The surface should feel "slick" when rubbing the cloth lightly over it. Avoid repeated wax applications which can cause wax to build up. Some very fine scratches or swirl marks may be removed by an application of a glaze. These types of glazes fill the scratches or swirl marks.

The motorhome has a large surface area. Washing and waxing may not be completed in one afternoon. Select sections to wax until the motorhome is complete. If the task seems overwhelming, have an automotive detailer perform the task.

---

Road oil will cause deterioration of the rubber. Dirt buildup will help hold chemicals in the air next to the tire and will also cause deterioration.

### ***Tire Care***

When cleaning any rubber product, proper care and methods in cleaning must be used to obtain the maximum service years out of the tires. Use a soft brush and a mild detergent to clean the tires. If a dressing product is used to "protect" the tires from aging, use extra care and caution. Tire dressings that contain petroleum products or alcohol may cause deterioration or cracking.

In many cases it is not the dressing that causes a problem but the chemical reaction that subsequently occurs. When these same dressing products are used on a passenger car tire that is replaced every three to four years, it is rare to see a major problem. However, in most cases recreational vehicle tires may last longer due to limited annual mileage and exposure.

- 
- Clean frequently with high pressure water from a hose. The use of mild detergent will speed the cleaning process. Do not use harsh alkalis, alcohol or acidic cleansers. A secondary hand washing with a soft cloth may be required to remove some stubborn road films.
  - When the tires are removed the entire wheel must be cleaned and inspected. With a wire brush or sandpaper remove dirt, corrosion or any foreign materials from the tire side of the rim. Do not use a wire brush or other abrasive substances to remove dirt and corrosion on the polished surface of the wheel.
  - To maintain the original appearance of the aluminum wheels the following procedures are recommended:

### ***Care & Maintenance of Aluminum Wheels***

1. After installing new wheels (prior to operating your motorhome) use a sponge, cloth or soft fiber brush to wash the exposed wheel surfaces with a mild detergent/warm water solution.
2. Rinse thoroughly with clean water.
3. Wipe dry to avoid water spots.
4. Use a high quality, non-abrasive polish to remove stubborn road tars, insects or hard to remove deposits.
5. To protect the appearance surface on Accu-Forge wheels, wax the cleaned surface with a high quality car wax.
6. Clean the aluminum wheels as frequently as required to maintain their appearance.

---

### **Bright Metal**

All chrome, stainless steel and aluminum should be washed and cleaned each time the motorhome is washed. Use only automotive approved non-abrasive cleaners and polishes on exterior bright work. Aluminum wheels should be cleaned regularly with a non-abrasive cleaner recommended for aluminum wheel care. Do not use rubbing compounds. Do not use any abrasive cleaners or compounds to clean the mirrors.



**NOTE: When using chemicals to remove road tars, use only automotive type products that are recommended for use on painted surfaces and fiberglass. Observe the warning recommendations and directions printed on the container of any agent being used.**

---

### **Maintenance - Exterior**

The motorhome is subject to a great deal of outside conditions. While the coach is parked it is exposed to extreme temperatures, humidity, ultraviolet rays, acid rain and other organic environmental conditions. While in operation the coach is subject to twisting and flexing caused by (for example) going in and out of driveways, bouncing through potholes and driving through winding mountain roads.

Periodic inspections of the fiberglass exterior may reveal minute cracks in the surface commonly called “spider cracks” or “hairline cracks” which are caused by the flexing of the fiberglass exterior. These are normal. If a crack represents a threat to the integrity of the fiberglass it will open up and the weave of the cloth would be visible. If the exterior has been damaged, prevent moisture penetration, especially in freezing climates. Cover the area as quickly as possible. Use plastic sheeting and tape, if necessary, so that moisture will not get into the motorhome and damage the interior.

**Roof Care &  
Seal Inspections**

Periodic resealing of the joints and seams is necessary to prevent the entrance of moisture into the motorhome. Enough emphasis cannot be placed on this issue. Extreme damage from a water leak can occur rapidly. Never leave the vehicle unattended with the slide room extended. If the vehicle is to be stored outside throughout the winter months, a full interior inspection for water leaks should be made bi-monthly.

Extensive sealing has been done at the factory; however, the normal twisting and flexing that occurs while traveling may have compromised a seal or seam. All joints and seams should be inspected at least twice a year and recaulked as necessary. Special attention should be directed toward the roof air conditioning seals, ceiling and plumbing vents, skylights, roof mounted antennas, windows, door molding, clearance lights and the beltline molding.

Specific sealant products should be used in the areas for which they were designed. These items can be obtained from recreational vehicle parts suppliers. Listed below are some of the more common sealants and the areas in which they are used. Approved sealants are available at service centers and authorized dealers.



**WARNING: Some products may contain hazardous materials which require special handling. Read labels carefully. Follow all of the product manufacturer's safety requirements.**

**Sealant Types****Acryl-R:**

Acryl-R is used on all roof openings such as vents, skylights, any roof mounted antennas and ladder roof mounts. The sealant should be applied only where the equipment bases meet the roof. Clean the old sealant that is lifting before applying with new. Make sure the roof is dry and free of dirt. This product is usually found in a caulking tube. Care should be used when near an edge, as the product will spread out. Masking tape may be used to mask around area to avoid mishaps. The roof air conditioners use a closed cell foam base gasket. No sealants are required. The roof air conditioners should be checked for tightness by the four mounting bolts located in each interior corner of the air conditioner roof opening. Torque specification is 40-50 in/lbs. The base gasket should be compressed to approximately one half inch.

**Acrylic Sealants (geocel 2300):**

This product is used where items are sealed under a painted surface such as the metal corners of the slide-out room. The material is specially formulated to allow paint adhesion.

**Black Urethane:**

This product is used for sealing the windshields. It was not designed to fill holes or other imperfections. Black urethane comes in a tube and it applies much the same way as silicone does. Clean up using solvents such as paint thinner. Gloves are required as this material is hazardous.

**Clear Silicone Sealant:**

Primarily this product is used on the sidewalls where a hole has been made and an item installed. This includes Windows, Doors, Handles, Beltline Molding, Latches and around bases of items surface mounted such as clearance lights. Old peeling sealant should be removed. Avoid using metal utensils which can scratch the painted surface. Use nylon sticks or equivalent. Avoid using lacquer thinners or ketone based solvents as these chemicals can damage the painted surfaces. Be sure the surface is clean and dry before application. Cut the tube at an angle with smallest usable opening. Avoid a heavy bead as a little goes a long way. Use finger at a 45° angle on beaded surface to smooth out product. Do not moisten finger, use a disposable latex glove. Keep rags or paper towels handy for clean up. Use care when applying silicone. Plan ahead before starting a bead, look for obstacles that may impede application.

**Spray Foam:**

This product is used as a sealant where a hole has been made for items such as water lines or wires that are coming through a floor opening.

---

**INTERIOR CARE**  
*Fabrics*

The fabrics have been manufactured with the same quality you would expect to find in a furniture store. If the fabric is abused, it can be damaged. Special care needs to be taken when your motorhome is exposed to a very humid climate for an extended period of time. Cover all upholstery and make sure window coverings are down to protect from sun damage.

Protect the fabric from any unnecessary exposure to moisture. The sofa, pillows, dinette cushions, living area chair, driver/passenger seating and window treatments have been treated with *Scotch Guard* to prevent overall water spots and soiling. Frequently used items will wear accordingly and may require more attention than those items not regularly used.

**Use the following guidelines for cleaning upholstery fabrics:**

- Water-based cleaners are not recommended.
- If a spill does occur, blot the soiled area. Do not rub it.
- Some solvents are not recommended since they may have an adverse reaction on backing of specific upholstery fabric.
- To prevent overall soiling, frequent vacuuming or light brushing are recommended to remove dust and grime.
- Clean spots using a mild water-free solvent or dry cleaning product.
- Clean only in a well ventilated area and avoid any product containing carbon tetrachloride or other toxic materials.
- Use a professional furniture cleaning service for overall cleaning.

**Fabric Cleaning Codes:**

The codes listed below refer to cleaning instructions recommended by the fabric manufacturer for specific fabrics. The “Fabric Specification Charts” (located on the following pages) list specific fabric codes under “Cleaning Code.”

“W” - Clean this fabric with the foam only of a water-based cleaning agent to remove the overall soil. Many household cleaning solvents are harmful to the color and life of a fabric. Cleaning only by a professional furniture cleaning service is recommended. To prevent overall soil, frequent vacuuming or light brushing to remove dust and grime is recommended.

“S” - Clean this fabric with pure solvents (petroleum distillate-based products such as *Energine*, *Carbona*, *Renuzit*, or similar products may be used) in a well ventilated room. Cleaning only by a professional furniture cleaning service is recommended.



**CAUTION: Use of water-based or detergent-based solvent cleaners may cause excessive shrinking. Water stains may become permanent and unable to be removed with solvent cleaning agents. Avoid products containing Carbon Tetrachloride as it is highly toxic. To help prevent overall soiling, frequent vacuuming or light brushing to remove dust and grime is recommended.**

“**S/W**” - Clean this fabric with the foam only of a water-based cleaning agent or with a pure solvent in a well ventilated room (petroleum distillate-based products such as *Energine*, *Carbona*, *Renuzit*, or similar products may be used). Cleaning only by a professional furniture cleaning service is recommended. To help prevent overall soiling, frequent vacuuming or light brushing to remove dust and grime is suggested.

“**P**” - The article is resistant against perchlorethene, cleaning benzine (spirit), white spirit, R-11 and R-13.

“**Dry Clean Only**” - Cleaning only by a professional dry cleaner or furniture cleaning service is recommended for this fabric.

**\*Machine Washing for 100% Polyester:**

“**Wash Cycle**” - Use synthetic setting and high water level with mild agitation. A mild soap or detergent in water not to exceed 160° F.

**No bleach or fabric softener.**

“**Drying**” - Use low temperatures, a synthetic setting of 85° F to 90° F maximum should be used. Do not exceed three to five minutes time on the synthetic cycle. If washed at 160° F, the maximum temperature which can be used to dry is 140° F. Hang or fold immediately after drying.

“**Finishing**” - If necessary, press as following:

- Iron on low setting (275° F) with damp cloth or steam iron using a dry press cloth.
- Grid Head press for short intervals with minimum steam. Do not lock the head.
- Flat bed press dampened drapery using cloth covering.
- Avoid prolonged contact with heat.

**Fabric Specification Charts**

<b>FABRIC</b>	<b>CONTENT</b>	<b>CLEANING CODE</b>	<b>WHERE USED</b>
<b>SUNSET .588 &amp; .640</b>			
29043 90C0001 Pebble	100% Polyester	Dry Clean Only	Bedsread, BR Valance, Headboard
492 Noah 346 Crimson	47% Rayon 37% Polyester 16% Cotton	S/W	LR Pillow, FSD, Dinette Cushion, LR Valance
Dempsey Chablis	100% Polyester	Dry Clean Only	Windshield
First Magnitude 016 M030926-018-1	35% Polyester 33% Cotton 32% Rayon	S	Chair, LR Pillow, BR Pillow, LR Valance
Maple Strie 65833/626	57% Polyester 30% Cotton 13% Rayon	S	Sofa, LR Valance
Serengetti Red	50% Polyester 50% Cotton	W/S	BR Pillow, BR Valance
Victoria Special Color	No Data Available	W/S	Trim, Fringe
<b>DUNES .589</b>			
Brag Vanilla	62% Rayon 27% Polyester 19% Nylon 10% Cotton	S	Sofa, LR Valance, LR Pillow
Costa Rica 007 M028315-007-1	64% Cotton 36% Polyester	S	Chair, LR Pillow, LR Valance
Cub 2012 Beige	100% Cotton	W/S	Bedsread, Headboard, BR Valance
Dempsey Chablis	100% Polyester	Dry Clean Only	Windshield
Giraffe Chenille Beige/Black	38% Rayon 34% Cotton 28% Polyester	S	LR Pillow, FSD, Dinette Cushion, BR Pillow, LR Valance
Juneau-AV Natural	100% Cotton	Dry Clean Only	BR Pillow, BR Valance
Victoria Special Color	No Data Available	W/S	Trim, Fringe

FABRIC	CONTENT	CLEANING CODE	WHERE USED
<b>PALMETTO .590</b>			
21090 91 Oyster	52% Rayon 48% Cotton	Dry Clean Only	Bedspread, BR Valance, Headboard
Dempsey Chablis	100% Polyester	Dry Clean Only	Windshield
R7347 Camel	40% Polyester 40% Acrylic 20% Viscose	S	Chair
Ravi-SH Olive	57% Cotton 43% Rayon	Dry Clean Only	BR Pillow, BR Valance LR Pillow, LR Valance
Senegal Elephant Chenille Beige/Black	40% Polyester 40% Acrylic 20% Rayon	S	BR Pillow, FSD, Dinette Cushion, LR Valance, LR Pillow
Tortoise Ivory F-0114562-01170111	56% Polyester 28% Cotton 16% Rayon	S	Sofa, LR Valance
Victoria Sage	70% Rayon Chenille 27% Rayon 3% Polyester	W/S	Trim, Fringe

\* See instructions for “Machine Washing 100% Polyester” under *Fabric Cleaning Codes*.

LR = Living Room    BR = Bedroom    FSD = Free Standing Dinette



<b>ULTRA-LEATHER</b>	<b>WHERE USED</b>	<b>CLEANING</b>
<b>SUNSET .588 &amp; .640</b>		Follow cleaning instructions for <b>Vinyl</b> under <b>INTERIOR CARE</b>
Tumbleweed Sand	Vinyl	
<b>DUNES .589</b>		
Tumbleweed Sand	Vinyl	
<b>PALMETTO .590</b>		
Tumbleweed New Oyster	Vinyl	

<b>LEATHER</b>	<b>WHERE USED</b>	<b>CLEANING</b>
<b>SUNSET .588 &amp; .640</b>		Follow cleaning instructions for <b>Leather</b> under <b>INTERIOR CARE</b>
Tumbleweed RVAA Sand	Leather	
<b>DUNES .589</b>		
Tumbleweed RVAA Sand	Leather	
<b>PALMETTO .590</b>		
Tumbleweed RVAA New Oyster	Leather	

<b>ULTRA-LEATHER</b>	<b>WHERE USED</b>	<b>CLEANING</b>
<b>SUNSET .588 &amp; .640</b>		Follow cleaning instructions for <b>Ultra-Leather</b> under <b>INTERIOR CARE</b>
291-3455 Milkweed	Ultra-Leather	
<b>DUNES .589</b>		
291-3455 Milkweed	Ultra-Leather	
<b>PALMETTO .590</b>		
291-3700 Ivory	Ultra-Leather	

## **Vinyl**

Several areas of the motorhome such as the dash, ceiling and items of furniture may be covered in vinyl. The care and cleaning of these areas are outlined in the Morbern Vinyl section below.

### **Morbern Vinyl:**

Vinyl requires periodic cleaning to maintain its neat appearance and to prevent the buildup of dirt and contaminants that may permanently stain and/or reduce the life of the vinyl if not removed. The frequency of cleaning depends upon the amount of use and the environmental conditions in which the vinyl is subjected. The procedures used for cleaning are dependent upon the end-use circumstances.

### **Normal Cleaning:**

Most common stains can be cleaned using warm soapy water and clear water rinses. Moderate scrubbing with a medium bristle brush will help to loosen soil from the depressions of embossed surfaces. For stubborn stains use the following commercially available mild detergents in accordance with the manufacturer's instructions: *Mr. Clean* or *Fantastik*. Full strength rubbing alcohol or mineral spirits may be tried cautiously as a last resort on very stubborn stains if the above suggestions do not work. Indiscriminate use of any solvent, or solvent containing cleaner, can severely damage or discolor the vinyl. Stains may become permanent if they are not removed immediately. The procedure for removal of the more severe staining agents are outlined below.



**NOTE: Detergents should never be used on a regular or repeated basis for normal cleaning.**



**CAUTION: Powdered cleaners containing abrasives, steel wool and industrial strength cleaners are not recommended for Morbern vinyl.**

### **Bird Excreta & Vomit Stains:**

Sponge the area with soapy water containing a diluted bleach until the stain is removed. Rinse thoroughly with clean water.

### **Urine Stains:**

Sponge with soapy water containing a small amount of household ammonia. Rinse thoroughly with clean water.

### **Surface Mildew:**

Wash with diluted bleach and use a soft brush for stubborn growth. Rinse repeatedly with clear, cold water.



**CAUTION:** Lacquer solvent will cause immediate irreparable damage to the vinyl. Do not use wax on any vinyl upholstery as it will cause premature embrittlement and cracking. Dilute chlorine bleach before using. Never use full strength bleach. If flammable solvents such as alcohol, turpentine or varsol are used for cleaning, use only small quantities while in a well-ventilated area. Exercise proper caution by notifying any persons in the area. Keep away from any ignition source. Always wear protective gloves.

**Ballpoint Ink:**

Permanent Marker Ink spots will stain the vinyl permanently. Wipe the stain immediately with rubbing alcohol in a well ventilated area to remove much of the stain.

**Oil-Base Paint:**

Use turpentine in a well ventilated area to remove any fresh paint. Dried paint must be moistened using a semi-solid, gel-type stripper. The softened paint can be gently scraped away. Rinse with soap and water.



**NOTE:** Paint strippers will remove the print pattern and damage the vinyl if it comes in direct contact.

**Latex Paint:**

Fresh paint can be wiped off with a damp cloth. Hot soapy water will normally remove dried latex.

**Tar or Asphalt:**

Remove immediately. Prolonged contact will result in a permanent stain. Use a cloth lightly dampened with mineral spirits and rub the stain gently, working from the outer edge of the stain toward the center to prevent spreading. Rinse with soap and water.

**Crayon, Mustard or Ketchup:**

Sponge with mild soap and water. For stubborn stains that may have set, use a cloth soaked in diluted mild detergent with gentle rubbing. Any remaining stain should be washed with diluted bleach. Rinse repeatedly with cold water.

**Chewing Gum:**

Scrape off as much gum as possible using a dull knife. Rub the gum with an ice cube to harden and make it easier to remove. In a well ventilated area, use a cloth saturated with mineral spirits and gently rub the remaining gum. Rinse thoroughly with clean water.

**Lipstick, Grease, Oil, Make-Up or Shoe Polish:**

Apply a small amount of mineral spirits with a cloth. Rub gently. Be careful not to spread the stain by smearing it beyond its original source. Remove shoe polish immediately as it contains a dye which will cause permanent staining. Rinse thoroughly with clean water.

**Candy, Ice Cream, Coffee, Tea, Fruit Stains, Liquor, Wine, Tanning Lotion or Soft Drinks:**

Use lukewarm water and sponge repeatedly. Any loose material should be gently scraped with a dull knife. Any soiled area that remains after drying should be gently rubbed with a cloth, dampened with a mild detergent solution. Rinse thoroughly with clean water.

**Blood or Plant Residue:**

Rub out any spots with a clean cloth soaked in cool water. If stubborn spots remain use household ammonia and rinse repeatedly with a clean, wet cloth. Do not use hot water or soap suds as this will set the stain.



**NOTE: Vinyl requires periodic cleaning to maintain its appearance and to prevent the buildup of dirt and contaminants that may permanently stain or reduce the life of the vinyl if left untreated. Frequency of cleaning and procedures used depend upon the amount of use and the environmental conditions in which the vinyl is subjected. Tears or holes in the vinyl can be temporarily covered with clear “office” tape to prevent further damage. Repairs should be made by a professional upholstery shop. Commercial repair products may contain lacquers and cause the vinyl to become brittle and more difficult to repair.**

---

**Leather**

**Spots & Spills:**

Absorb excess liquid immediately with a clean cloth or sponge. Use water only if necessary. Do not use a cleaning product. If water is used, clean the entire area where the spot occurred. An example would be the entire seat cushion or the entire arm. Allow to air dry. Do not dry the wet areas with hair dryers, etc.

**Stubborn Spots and Stains:**

Use lukewarm water and a mild soap to work up a thin layer of suds on a piece of cheesecloth. Scrub the surface. Rinse with a piece of clean, damp cheesecloth. Allow to air dry. Do not use saddle soap, cleaning solvents, furniture polish, oils, varnish, abrasive cleaners, soaps or ammonia water.



**NOTE: These are recommended or suggested methods of cleaning. The manufacturer is not responsible for damage incurred while cleaning. Always test the cleaning method in an inconspicuous area first before applying to the entire area.**

**Care Instructions:**

- Spot clean with mild soap and water
- Air dry or dry quickly with warm setting of a hair dryer.
- For stubborn stains, use mild solvent.
- For tougher stains, try *Fantastik*® brand spray cleaner.
- Disinfect with a 5:1 **NON- CHLORINATED** (only) bleach solution.
- Dry clean using commercial dry cleaning solvents only.
- Use a mild detergent for:
  - Red Wine, Liquor - Coffee, Tea, Coca Cola - Milk
  - Ketchup, Mustard, Mayonnaise - Steak Sauce, Soy Sauce
  - Butter, Salad Oil - Chocolate - Lipstick, Make-up, Face Cream
  - Suntan Oil - Machine Oil - Urine, Blood

**Removing ballpoint pen stains:**

Wipe the stain off with ethanol (ethyl alcohol). If the stain cannot be removed with ethanol, use the following procedure. Proceed with caution when using toxic chemical.

- Prepare bleach. Dilute household bleach (sodium hypo chloride) with the same amount of water.
- Place a piece of tissue and apply the solution prepared by step 1 (do not apply too much). Cover it with polyethylene film to prevent the solution from drying.
- Remove the tissues occasionally to check on the condition of the stain. When the stain is almost gone, remove the tissues completely. Do not leave on for more than one hour.
- Wash the stain with sufficient amount of water.

If there is residue of bleach, polyurethane resin and back cloth will deteriorate. Therefore, neutralize it by the following method:

- Place a piece of tissue as in step 2, and apply hydrogen peroxide solution (15%).
- Leave the solution on for approximately 30 minutes, then remove the tissue.
- Completely remove the residue of hydrogen peroxide on the ultra-leather with water.

Sodium hypo chloride is the only chemical that will remove ballpoint pen stains. However, this chemical may cause polyurethane to yellow or the back cloth to deteriorate. It is recommended to remove ballpoint pen stains as early as possible with ethanol.

**For more information, please call: Ultrafabrics, LLC**  
**Sales and Marketing: 1-888-361-9216**  
**Customer Service: 1-877-309-6648**

**Floors - Carpet Cleaning**

Use the solution specified in order from 1-8 until stain is removed.	A DRY CLEANING FLUID	B NAIL POLISH REMOVER	C DETERGENT SOLUTION	D WARM WATER	E VINEGAR SOLUTION	F AMMONIA SOLUTION	G SPOT REMOVAL KIT	H CALL PROFESSIONAL	I PERMANENT CHANGE
<b>SPOTS</b>									
Acid				2		1	3	*	
Acne Medication		1		2	5	4	3	6	*
Alcoholic Beverage			1	4	3	2			*
Ammonia				2	1				*
Bleach		1	2					3	*
Blood		1	3		2	4			
Candle Wax	1					2			
Cement & Glue	2	1	3		5	4	6		*
Chalk		1	2						
Charcoal		1	2						
Chewing Gum	1								
Coffee			1	3	2		4	5	*
Cosmetics		2	1	3	6	5	4	7	*
Crayon	1		2	3					
Drain/Toilet Cleaner			2	1	3			4	*
Dye	1		2		4	3	5	6	*
Food			1	4	3	2	5	6	*
Fungicides/Insecticides/Pesticides	1		2	5	4	3	6		*
Furniture Polish (Water Based)			1	4	3	2	5	6	*
Furniture Polish (Solvent Based)	2	1	3	6	5	4	7	8	*
Furniture Stain	2	1	3	6	5	4	7	8	*
Graphite		1	2						
Grease	1	2	3				4	5	*
Ink	2	1	3	6	5	4	7	8	*
Iodine	1		2	5	4	3	6	7	*
Lipstick	2	1	3	6	5	4	7	8	*
Medicine	2	1	3	6	5	4	7	8	*
Merthiolate			1	4	3	2	5	6	*
Nail Polish	2	1	3				4	5	*
Oil	1		2	4		3		5	*
Paint	2	1	3				4	5	*
Plant Food			1	4	3	2	5	6	*
Rust			2	3	1		4	5	*
Shoe Polish	2	1	3	5		4	6	7	*
Soft Drinks			1	4	3	2	5	6	*
Soot	1		2	3				4	*
Tar	1						2	3	*
Toothpaste			1						
Urine			1		2		3	4	*
Vomit			1	4	3	2	5	6	*

**Spot Removal Procedures:**

- Act quickly when anything is dropped or spilled. Remove spots before they dry.
- Blot liquids with a clean, white absorbent cloth or paper towel.
- For semi-solids, scoop up with a rounded spoon.
- For solids, break up and vacuum out as much as possible.
- Pretest the spot removal agent in an inconspicuous area to make certain it will not damage the carpet dyes.
- Apply a small amount of the cleaning solution recommended for the particular spot. Do not scrub. Work from the edges of the spot to the center. Blot thoroughly. Repeat until spot is removed.
- Follow steps on the Carpet Spot Removal Guide.
- After each application, absorb as much as possible before proceeding to the next step.
- Absorb remaining moisture with layers of white paper towels, weighted down with a non-staining glass or ceramic object.
- When completely dry, vacuum or brush the pile to restore texture.
- If the spot is not completely removed, contact a professional carpet cleaner.

**Cleaning Solutions:**

**(A) Dry Cleaning Fluid:** A nonflammable spot removal liquid, available in grocery and hardware stores.

**(B) Nail Polish Remover:** Any acetate, which often has a banana fragrance. Do not use if it contains acetone.

**(C) Detergent Solution:** Mix two cups of cold water and 1/8 teaspoon mild liquid detergent (no lanolin, non-bleach).

**(D) Warm Water:** Lukewarm tap water.

**(E) Vinegar Solution:** One cup white vinegar to one cup water.

**(F) Ammonia Solution:** One tablespoon household ammonia to one cup water.

**(G) Spot Removal Kit:** Available from retail carpet stores or professional cleaners.

**(H) Call Professional:** Additional suggestions, special cleaning chemicals or the ability to patch the area might be available.

**(I) Permanent Change:** Due to the nature of the stain, there may be color loss. The carpet has been permanently dyed or the carpet yarns have been permanently damaged.



**NOTE: While the recommended cleaning agents have proven to be effective, some stains may become permanent.**

The laminate flooring used in the motorhome provides style, durability and easy maintenance. The laminate flooring is a high pressure laminated flooring designed to be incorporated as a floating floor. The flooring material is constructed of three main components. The surface, similar to many countertops, contains aluminum oxide particles to form an extremely hard, durable surface. The carrier or core layer is constructed from high density fiberboard. A tongue and groove design will allow for a tighter bond. The backer or bottom layer is also made of laminate for balance and strength.

## **Floors - Laminate**

### **Care and Cleaning:**

Everyday cleaning is as simple as vacuuming the floor to remove dirt and debris. A cotton string mop is recommended for occasional mopping with a minimal amount of water. Use a mixture of soap-free household cleaner and water (vinegar and ammonia both work well) for a more thorough cleaning.

- Stains should be wiped away with a damp cloth.
- Stains caused by inks or paints may require a cloth moistened with acetone (nail polish remover).
- Stains caused by gum or tar should be allowed to harden completely, then gently scraped away.
- Felt protectors on the bottom of furniture and floor mats can preserve the beauty and appearance of the flooring.



**CAUTION: Abrasive cleaners and scouring pads can scratch and damage the flooring. Never wax, sand or apply lacquer to laminate flooring.**



**NOTE: Any unusual or unique problems can be addressed by contacting Wilsonart at (800) 433-3222.**

## Shower - Cleaning

Showers are susceptible to soap build up. Showers should be cleaned weekly to prevent burdensome clean-up. Using the same solution used to clean tile floors will be sufficient for the shower. However, to control mildew growth spray the shower with household chlorine bleach and allow it to stand for five minutes. Clean the glass shower doors with window cleaner on a weekly basis to maintain the shine. If water spots cannot be removed from the glass, rub lightly with the flat edge of a razor blade to remove deposits.

To prevent excessive moisture and a continual growth of mildew, use the shower only with adequate ventilation. The sealant in a regularly used shower should be replaced once a year. To replace sealant, remove the old sealant using a sharp instrument. Apply a new sealant, which can be found at most recreational vehicle supply stores.

---

## Ceilings

The ceiling of the motorhome can be a variety of materials or fabrics, many of which require little or no care or maintenance.

### Vinyl:

The soft touch padded vinyl ceiling can be cleaned using the procedures discussed in the vinyl article of this section. Generally, a mild soap and water is sufficient for cleaning vinyl.



**NOTE: Use care not to puncture the padded vinyl.**

### Ozite:

To clean the ozite ceiling, mix a solution of 8 oz. warm water, 4 oz. white vinegar, 1 oz. bleach and 4 oz. club soda. Spritz on and blot dry. Do not rub or scrub as this may damage the surface.



**NOTE: Do not over-saturate the Ozite surface as this may damage the ceiling.**

### Hardwood Vinyl & Decorated Paneling:

Hardwood vinyl and decorated paneling are sensitive and demanding materials. Certain cleaning agents will affect the surface on both printed and unprinted vinyl. Use only a mild, non-abrasive detergent and warm water with a soft cloth or sponge for cleaning to protect the material.

Under no circumstance should bleach, alcohol, oil-based spray cleaners or cleaning agents with solvents, citrus oil or harsh chemicals be used. Other liquid spray cleaners may also cause damage to the material.

---

## Wall Coverings

Time is very important when removing substance from wall coverings that are solvent based or contain color. Do not use abrasive cleaners containing chlorine bleach or solvents. (*Fidelity* and *Jolie* brands are recommended.) Always begin with a mild detergent or soap and warm water. To remove normal dirt clean with a soft sponge. Rinse and wipe dry.



**Care for the Satinesque Wall Covering:**

Any stain should be removed as quickly as possible to minimize any reaction between the staining agent and the wall covering. Time is very important when removing substances that are solvent based or contain color. Examples: nail polish, oil, shampoo, lacquer, enamel, paint, ink and lipstick.

Always begin cleaning with a mild detergent such as soap. If necessary, move to a stronger cleaner such as household bleach, liquid household cleaners or rubbing alcohol. Before using one of the stronger cleaners test the cleaning agent on a small inconspicuous portion of the wallcovering to make sure that the cleaner does not affect the color or gloss of the wall covering.

**Normal Dirt:**

Remove normal dirt using a mild soap or detergent and warm water. Allow it to soak for a few minutes then rub briskly with a cloth or sponge.

**Nail Polish, Shellac or Lacquer:**

Remove liquid using a dry cloth. Use care not to spread the stain. Quickly clean the remaining stain with rubbing alcohol. Rinse with clean water.

**Ink:**

Remove immediately by wiping with a cloth dampened in rubbing alcohol. Rinse with clean water.

**Chewing Gum:**

Rub with an ice cube to cool and harden. Gently pull off the bulk of the gum. Remove any remaining gum with rubbing alcohol.

**Pencil:**

Erase as much of the pencil mark as possible. Wipe any remaining marks with rubbing alcohol.

**Blood, Feces or Urine:**

Remove these staining substances as quickly as possible. Wash the stained area with a strong soap. If the stain does not disappear, rinse the soapy area thoroughly with clean water. Mix a solution of 50% water and 50% household bleach. Clean the stained area with the bleach solution. Rinse with clean water.

**Care for the Tower Wall Covering:**

Remove ordinary stains with mild soap and warm water. Sponge on. Rinse well and dry with a soft cloth. **For special cleaning problems:** To remove ball point pen, blood, lipstick, etc., use a sponge or soft bristle brush and *Formula 409*, *Fantastik* or a similar product. Rinse well and dry. Finish cleaning by applying full strength isopropyl alcohol with a sponge or soft brush. Rinse well and dry.

## Wood Care

Wood should be treated the same as a piece of fine furniture. Care and cleaning of the wood surface is essential in maintaining the natural beauty of wood. Keep in mind that wood finishes can vary widely. Test a new cleaning solution in an inconspicuous area to check for possible damage.

The care and cleaning of the solid wood surfaces and the wood products used in the motorhome depends on individual choices and preferences. Numerous waxes, polishes and finishing products are available for use. Always follow the manufacture label and instructions. The solid wood surfaces should be cleaned weekly. Dust regularly with a soft, lint-free cloth. Dampen the cloth slightly with water. Wipe one small area at a time and dry immediately.

For stubborn stains, use a clean cloth dampened with a solution of mild, non-alkaline soap (like dishwashing liquid) and water. Dry thoroughly using a soft cloth. Buff lightly, following the direction of the grain. Never use abrasive cleaners, scouring pads or powdered cleansers.

Excessive dampness, dryness, heat, or cold can damage solid wood finishes. Sunlight can change the color or age the wood. Never allow moisture or spills to stand, always blot dry immediately. Solvents, alcohol, nail polish and polish removers, as well as harsh cleaners should not be used on finished wood surfaces.

Minor damage to solid wood surfaces can be repaired quickly and effectively with a bit of hard work, some careful attention to details, and most importantly, the right materials. However, any wood repair or finishing job is best left for a professionally trained individual.



**NOTE: It is important to inform the service technician of any products used for the care and cleaning in the event of wood repairs.**

### Sanding and Sandpaper:

The following table is a general guide to the proper uses, although this may vary from wood type to type. The key to sanding is using the right sandpaper for the repair that is needed. Always sand with the grain.

<b>GRIT</b>	<b>Common</b>	<b>Common</b>
80-120	Medium	Smoothing the surface, removing small marks.
150-180	Fine	Final sanding prior to finishing.
220-240	Very Fine	Sanding between coats of sealing.
280-320	Extra Fine	Removing dust spots or mark between finish coats.
360-600	Super Fine	Fine sand of the finish to remove luster or surface blemishes.

### Steel Wool:

Abrasive material composed of long steel fibers of varying degrees of fineness that are matted together. The coarser grades are used to remove paint and other finishes; the finer grades for polishing or smoothing a finished surface.

**Nail Holes and Small Cracks:**

Fill nail holes and small cracks with wood putty or dough for unstained woods prior to any sanding. Stained finishes require filling holes and cracks after the stain has been applied. Putty should match the stain closely in color.



**NOTE: A little sawdust and wood glue can be used to make putty for end grains.**

**Fixing scratches in stained woodwork:**

"Quick and simple" rarely describes repairs to stained wood finishes. However, a few tricks can be tried. When scratches appear lighter than the surrounding dark-stained woodwork, it usually means either that the scratch goes through the stain into the wood or that the varnish is flaking off.

**Dents:**

Dents are the results of wood fibers being crushed and compressed. Dents can be raised back to original level by steam. To raise a dent, place a damp cloth over the dent and hold a medium-hot iron on it. The steam will cause the wood fibers to swell back into place. It may be necessary to repeat this process until the dented area is level with the surface. Allow the area to dry.

**Restoring the clear finish:**

Inspect the scratches carefully. If flaking varnish is visible with dark-stained wood underneath, only the clear finish may need to be restored. Rub the loose varnish with fine steel wool or fine synthetic steel wool until you have removed the flaking varnish and slightly roughened a small area of the finish surrounding the scratch. With the tip of rag, a small brush, or even a cotton swab, apply a thin coat of a wipe-on finish. Apply finish to the damaged area only. Several coats may be needed to hide the scratch.

**Re-staining the wood:**

If bare wood is visible at the bottom of the scratch, the wood will need to be re-stained. To remove damaged varnish, lightly roughen a small area around the scratch with sandpaper, steel wool or synthetic steel wool. Find a stain that is a shade lighter than the wood finish. Stain the bare wood with a very small amount of stain on a rag, brush or cotton swab. If the color is too light, apply several coats. Rub away excess stain with a dry rag. If the wood becomes too dark, use a rag moistened in mineral spirits to lighten the wood. Select a lighter color stain and continue.

Several companies have simplified this repair process by putting oil-based wood stain into marker-like containers. Just rub the stain marker on the scratch. Start with a stain color that is lighter than the original finish, because torn and scratched wood fibers will absorb stain quickly and darken quickly. A second coat can always be applied if the color of the first coat is too light.

Once the color is blended, patch the clear finish as described above and apply a wipe-on finish.

### **Scratches and Nicks:**

Several professional woodworkers use similar procedures and tricks when it comes to scratches and nicks, most of which can be easily repaired. Always test an inconspicuous area of the wood prior to repairs to ensure no damages to the finish.

Light scratches will often disappear when carefully rubbed with furniture polish or paste wax. Deeper scratches can be hidden by carefully rubbing with a piece of oily nutmeat such as Brazil nut, black walnut or pecan. Be careful to rub the nutmeat directly into the scratch to avoid darkening of the surrounding wood. Color the scratch with brown coloring crayon or liquid shoe dye (especially good on walnut).

Staining the scratch with iodine:

Mahogany - Use new iodine.

Brown or Cherry Mahogany - Use iodine that has turned dark brown.

Maple -Dilute one part iodine with one part denatured alcohol.

Commercial scratch removers or stick wax to match the wood finish can also be used. After the scratch has been hidden, polish or wax the entire area. Deep scratches should be repaired and finished by a professionally trained individual.

---

## **Countertops**

The Solid Surface was created for a lifetime of easy care. Just follow the simple guidelines listed here to the keep countertop surface looking nice.

### **Routine Care:**

The motorhome countertops are finished with one type of finish: matte/satin. All solid surface sinks and bowls have a matte/satin finish. Soapy water or ammonia-based cleaners will remove most dirt and stains from all tops and bowls. However, slightly different techniques must be used to remove different stains. Follow the recommendations below.

### **Cleaning Countertops:**

- Most dirt and stains: Use soapy water or ammonia-based cleaner.
- Water marks: Wipe with damp cloth and towel dry.
- Difficult stains: Use soft scrub and a Grey *Scotchbrite* Pad.
- Disinfecting: Occasionally wipe surface with diluted household bleach (one part water and one part bleach).

### **Cleaning Solid Surfaces Sink:**

Occasionally clean by using *Soft Scrub Liquid Cleanser* and a Grey *Scotchbrite* pad. Scrub the sink, rinse and towel dry. Do this as often as necessary.

### **Removing Cuts and Scratches:**

Because the beauty of the surface goes all the way through the Solid Surface, countertops are completely renewable. Use the following instructions to remove minor cuts and scratches.

- Sand with 180 grit and then 320 grit sandpaper until the scratch is gone.
- Restore the finish using a Grey *Scotchbrite* pad. Never sand hard in one small area. Feather out lightly to blend restoration.

### **Preventing Heat Damage:**

The Solid Surface withstands heat better than ordinary surface materials; however, hot pans and some heat-generating appliances, such as frying pans or crockpots, can damage the surface. To prevent heat damage always use a hot pad or a trivet with rubber feet to protect the surface. In most cases the surface can be repaired if it is accidentally damaged.

### **Other Important Tips:**

Avoid using strong chemicals on the Solid Surface such as paint removers or oven cleaners. If these chemicals come in contact with the Solid Surface, quickly wash with water. Avoid contact with nail polish or nail polish remover. If contact is made, quickly wash with water.



**NOTE: Do not cut directly on the solid surface. Always run cold water into the Solid Surface sink when pouring boiling water into the sink.**

### **Water Spots:**

Any glass will develop water spots if not cleaned properly. A spotting effect is magnified when the glass has a reflective finish. Use a squeegee immediately after washing to reduce water spotting. To remove stubborn water stains from reflective glass we recommend *Cerium Oxide Polishing Compound*, made by C.R. Lawrence, available at most glass shops.

### **Condensation:**

Condensation is a natural phenomenon. The amount of condensation will vary with climate conditions, particularly in relative humidity. Condensation occurs from water vapor present in the air. Each of us add more vapors by breathing, bathing, cooking, etc. Water vapor collects wherever there is available air space. When the temperature reaches the dew point the water vapor in the air condenses and changes to liquid form.

---

## **Windows**

### **Controlling Moisture Condensation:**

Reduce or eliminate interior moisture condensation during cold weather by using the following steps:

- Partially open the roof vents and windows so that outside air can circulate into the interior. Increase the ventilation when large numbers of people are in the motorhome. Even in raining or snowing conditions the air outside will be far drier than the interior air.
- Install a dehumidifier. Continuous use of a dehumidifier is effective in removing excess moisture from the interior air. Using a dehumidifier is not a cure-all, however, it will reduce the amount of outside air needed for ventilation.
- Run the range vent fan when cooking and the bath vent fan (or open the bath vent) when bathing, to reduce water vapor. Avoid excessive boiling or use of hot water as it produces steam.
- Do not heat the motorhome interior with the range or oven. Heating with the range or oven increases the risk of toxic fumes and allows oxygen depletion. Also, open flames add moisture to the interior air increasing condensation.
- In very cold weather leave the cabinet and closet doors partially open. The air flow will warm and ventilate the interior of the storage compartments and the exterior wall surface, reducing or eliminating condensation and preventing the possibility of ice formations.

---

## **Mold & Mildew**

### **What is Mold?**

Mold is a vegetative growth or a plant belonging to the Fungi group. Being a plant, mold will need food to grow. Mold growth can be a result from moisture and certain temperatures. Some molds can cause mildew wherever there is poor air circulation, poor lighting, damp and warm areas. Molds, as they grow will cause considerable damage and leave a musty odor, discolor fabric, and stain surfaces. Molds produce microscopic cells called "spores" that can spread easily through the air.

### **What does mold need to grow?**

Mold only needs a few simple things to grow and multiply: moisture, nutrients and a suitable place to grow. Prevention of mold and mildew begin with keeping things clean. Greasy films contain many nutrients for mildew causing molds when moisture and temperatures are right. Soil on dirty items, such as fabrics and furniture, may supply enough nutrients for mold to grow. Many of the synthetic fabric such as acetate, polyester, acrylic and nylon are mildew resistant. However, soil on these fabrics may supply the nutrients to start mold growth. Any soiled fabric should be cleaned thoroughly to help prevent mildew from occurring.

### **Indoor Air Regulations and Mold:**

Standards, or threshold limit values, for concentration of mold or mold spores have not been set. Currently, there is no EPA regulations or standards for airborne mold contaminants. There is simply no practical way to eliminate all mold and mold spores in the indoor environment. For example, studies have shown that ozone cleaners are not effective at killing airborne mold or surface mold contamination.

### **Basic Mold Cleanup:**

The key to controlling mold is keeping things clean and limiting moisture. If mold is a problem in the motorhome, here are some suggestions on resolving the condition:

- Eliminate the source of the water problem or fix the leak to prevent mold growth.
- Materials or furnishing must be cleaned and dried within 24-48 hours to prevent mold growth.
- Clean mold off hard surfaces with water and detergent. Dry the surface completely.
- Reduce indoor humidity to 30-60% to decrease mold growth by venting bathrooms, dryers and other moisture-generating sources to the outside using conditioners and de-humidifiers. Increase ventilation by using exhaust fans when cooking, dishwashing, showering and cleaning.
- Open doors between rooms (especially doors to closets that may be colder than the rooms) to increase air circulation.
- Respond promptly when you see signs of moisture and/or mold. Repair leaks or wipe spills immediately.
- If materials with mold cannot be cleaned, they should be removed and properly disposed.

Mold and mildew can develop in the motorhome just as it can in a residential home. Taking the above steps at home, and in the motorhome, are ways to control moisture prevent molds from growing.

- 
- To maintain the mini-blinds, on a frequent basis vacuum with the brush attachment or use dusting tools (available on the market) designed specifically for mini-blinds.
  - Wash the mini-blinds with mild soap and water in a tub or hang the blinds on a fence or wall and gently rinse them with a hose.

### ***Mini-blinds***

### **Day/Night Shades (Bedroom)**

The day/night shades are made of polyester blended material. Use the following guidelines to care and maintain the day/night shades:

- Vacuum with a brush attachment. Use a dusting tool regularly.
- Use a weak solution of dish soap and water to spot clean the shades with a slightly damp cloth. Avoid soaking or saturating the shades with water. Over saturation will break down the finish of the shade.
- Leave Day-Night shades in the **UP** position when not in use to help the shades hold their shape.
- String tension for the shades should be equal. The tension can be adjusted if the shades will not remain up.

---

### **STORAGE - Short Term**

Short term storage is defined as storing the motorhome for a period of thirty days or less. Properly preparing the motorhome during periods of short term storage will make bringing the motorhome out of storage a much easier process. Winterize the plumbing system if the motorhome is stored in winter months or if stored when temperatures are below 32° F.

#### **Checklist-Short Term Storage**

- If applicable, retract the slide room(s). Do not store the motorhome with slide room(s) extended.
- Shut off all appliances. Close the primary LP-Gas valve.
- Remove all articles from refrigerator/freezer and clean thoroughly. Prop doors open to prevent mildew.
- Holding tanks should be drained and fresh water system winterized, with potable antifreeze or winterize the plumbing system using air pressure.
- Retract and secure all awnings.
- Turn OFF the battery cut-off switch.
- Batteries should be stored fully charged. Batteries stored in a discharged state will readily freeze.
- If possible, park the motorhome so that the batteries are accessible for charging or changing without having to move the motorhome.
- If available, leave the motorhome hooked to shore power. Leave the main battery disconnect switch **ON**.
- Careful placement of a small heat source in the interior will help control moisture. Desiccate filter systems will help remove interior moisture.
- If AC power is not available turn the chassis battery disconnect switch **OFF**.
- If possible, store the motorhome inside a storage building.
- If stored outside, inspect all seams and seals for possible leakage.



- Store the motorhome with a full fuel tank to minimize moisture condensing at top of fuel tank.
- Vents and windows should be closed to prevent wind driven rain entrance.
- Tires should be stored at maximum inflation pressure.
- A full interior inspection for water leaks should be made bi-monthly, inspecting behind all cabinet doors and drawers.

---

Long term storage of the motorhome can be defined as leaving a motorhome unattended for a period of thirty days or more. A motorhome requires protection from the elements just as a house or a car would. When left out in the environment without proper storage or maintenance, a motorhome, house or car is vulnerable to the moisture and oxidation processes inherent in the environment.

There are preventative measures which should be taken and preferable situations to use when storing a motorhome. Such measures will aid in protecting and preventing a motorhome from the damaging effects caused by an accumulation of moisture.

## **STORAGE - Long Term**



**NOTE: The natural process of moisture in the air condensing will occur with temperature changes of 30° F or more in one day. Humidity readings of 60% or greater will allow the accumulated moisture to remain for extended periods of time.**

**If the motorhome is stored in a location where AC power is not available:**

- Turn off all the appliances.
- Turn off the battery cut-off switch.
- If possible, situate the motorhome so the batteries remain accessible. This allows a battery to be charged or replaced without moving the motorhome.
- Charge the batteries to a full state of charge.
- Turn the main battery disconnects to **OFF**.
- When stored outside, use the available DC Volt meters to make a quick reference check of the batteries while the motorhome is in storage. If the motorhome is stored outside, solar panels may offset the parasitic loads.
- Preventative measures should be used if the voltage readings are low. When using preventative measures, taking the motorhome out of storage or moving the motorhome in case of an emergency is a much easier process.



**NOTE: Batteries in a low state of charge will readily freeze. Freezing will damage the battery.**

**If AC power is available:**

The chassis battery disconnect switch will remain **ON**. The inverter will charge both house and engine battery banks. A 30 Amp shore power service will be more than adequate.



**CAUTION: A 20 Amp service using light duty extension cords and the required adapters create serious voltage losses. Line voltage loss and the resistance at each electrical connection is a hazardous combination and should be avoided. Damage to sensitive electronic equipment may result!**

**Type of surface to park and store the motorhome on:**

- The type of surface the motorhome is parked upon will affect how much moisture accumulation occurs on the chassis and flooring. Moisture can eventually seep into the interior.
- Parking the motorhome on a grass surface, with the tires supported by blocks, is a perfect situation for moisture to accumulate.
- A gravel covered parking area still allows moisture to evaporate from the ground, through the gravel and to the underside of the motorhome.
- Concrete pads seal the surface allowing better ventilation under the motorhome.
- Storage buildings with concrete floors, or heated storage facilities, greatly reduce the amount of moisture accumulation and protects the motorhome from moisture damage.

**If the motorhome is stored outdoors:**

- The interior should be heated to help prevent mold and mildew growth. Moisture removing desiccate filter systems are available from hardware and RV supply stores. Place the filter system inside the motorhome to reduce inside moisture condensation or humidity. These systems help control mold and mildew growth.
- Proper winterization of the fresh water system will prevent potential damage in extreme cold.
- Ultraviolet radiation affects soft goods and rubber products such as privacy curtains, window shades and tires. These items should be protected.
- Cardboard templates can be made for the windows to protect these items from exposure to direct sunlight.
- Tire covers are available to protect the sidewall of the tires from cracking. Make sure the tires contain the correct air pressure. Underinflated tires can be damaged.
- Washing the exterior regularly will help control moss accumulation. The clear coat has UV protective substances. Waxing the motorhome twice a year will augment these substances.

**Inspect the motorhome:**

- Perform a full interior inspection for water leaks every two weeks while the motorhome is in storage. Open all cabinet doors looking for signs of dampness or leaks. Inspect the ceiling areas around roof vents or other roof openings.
- The roof and sidewall seams should be inspected and cleaned at least twice a year. Inspect for exterior sealant gaps of all roof seams, vents, skylights, roof air conditioners and windows. If necessary, use the proper sealants and recommended application procedures.

**Fuel:**

A full tank of fuel will help minimize moisture condensing at the top of the tank. Diesel fuel is an organic material which will develop a microbe growth (black slime). Fuel stabilizers may be added to control microbe growth and degrading of the fuel. Consult the Cummins manual or a Cummins distributor for further detailed information on fuel stabilizers and additives.

**Brakes:**

Brakes also suffer from non-use during periods of storage. The bare metal machined surfaces of brake drums or rotors have only a light coating of dust from the brake lining friction material. The brake dust is the only thing protecting the bare metal surfaces from rusting. Only regular brake applications dry the moisture preventing rust on brake drum or rotor surfaces. During periods of non-use, oxygen and moisture oxidize the machined surfaces. Only occasional use keeps these surfaces from oxidizing. Rusty brake drum or rotor surfaces permeate the brake linings upon the first few applications, reducing the friction action of the linings.

**Engine:**

Internal combustion engines need to be “exercised” on a regular basis. This will ensure that an adequate supply of lubricating oil coats the cylinder walls and piston rings. Valve and valve seat surfaces also suffer from non-use. Some valves will remain open depending at which part of the combustion cycle the engine has stopped. The heat and cold of the day allows moisture to accumulate through the exhaust system.

**Electric Motors:**

Electric motors in the motorhome should be operated occasionally to help lubricate and keep surfaces rotating freely. These items include the roof air conditioners, dash fans, dash blower motor, furnace or Aqua Hot motors, heat exchangers and powered roof vents.

## CHECKLIST - Winter Storage

- **Plumbing Lines** - Drain and protect by filling with approved RV antifreeze.
- **Fresh Water Tank** - Drain.
- **Body** - Clean and wax. Oil locks and hinges. Repair roof seams as needed.
- **Countertop and Cabinets** - Wash with mild soap and water.
- **Curtains** - Remove and clean according to care specifications.
- **Windows** - To protect the interior fabric from fading, cover windows by pulling blinds, closing shades or using a separate cover such as a sheet.
- **Holding Tank** - Drain and rinse. Close valves.



**Add a small amount of antifreeze to keep valves and gaskets lubricated.**

- **Drain Traps** - Pour RV antifreeze down all drains.
- **Refrigerator** - Clean and leave both doors propped open. Cover the exterior panels and roof vents.
- **Batteries** - Add distilled water and recharge if needed. Disconnect the cables. Remove the batteries and store them in a cool dry place. Check and recharge as needed. Never park the coach where the battery door cannot be opened.
- **Air Conditioner** - Remove the air filters. Clean or replace.
- **Roof** - Keep clear of snow accumulation or damage may occur.
- **Interior/Exterior** - Storing under cover or indoors helps extend interior and exterior life.
- **Fuel Tank** - Diesel fuel tank should be full of fuel.

---

## STORAGE - Removal

If the motorhome was properly and carefully prepared for storage, removing it from storage will not be difficult. The following checklist pertains to items or areas which should be checked before operating or moving the motorhome. If the motorhome was not properly winterized, extensive freeze damage or other serious deterioration may have occurred. Consult a dealer or an authorized service center for advice.

- Thoroughly inspect the outside of motorhome. Look for animal nests in the wheel wells or in other out of the way places.
- Remove all appliance flue vent covers, ceiling vent covers and air conditioning covers. Be sure the refrigerator openings are free of debris, insect nests, webs, etc.
- Open all doors and compartments. Check for animal or insect intrusion, water damage or other types of damage which may have occurred.

- Check the state of charge of the batteries. If necessary fill the cells with distilled water only and charge as necessary. Inspect the cable ends and terminals. They should be clean and free of corrosion.
- Check all the chassis fluid levels: engine oil, engine coolant, hydraulic fluid reservoir, transmission oil and rear axle oil.
- Start the engine, allowing it to reach operating temperature. Ensure the engine instruments are indicating proper readings.
- While the engine is running check the operation of headlights, tail-lights, turn signals, back-up lights, license plate light and emergency flasher. Operate the dash air conditioner. If the air conditioner does not work, or the compressor makes unusual noises, have the system checked by a qualified air conditioner technician.
- Shut the engine down. Adjust or add fluids as necessary. Inspect the engine for fluid leaks. Look under the motorhome for any other type of fluid leaks.
- Drain, sanitize and flush the fresh water system as outlined in the **Water Systems - Section 6**. Inspect the sewer drain hose and connections for leaks. Replace if necessary.
- Operate all faucets and fixtures in the fresh water system. Run a sufficient amount of fresh water through all the water lines and faucets to thoroughly purge any potable antifreeze from the fresh water system.



**NOTE: Discard at least the first two trays of ice from the icemaker to ensure the ice does not contain traces of antifreeze or other contaminants.**

- Open cabinet doors and drawers inspecting for water leaks at joints or fittings. Repair as necessary.
- Operate all 12 Volt lights and accessories. If something does not work there may be a bad 12 Volt circuit breaker or blown fuse.
- Install new batteries in battery operated safety detectors or devices. Test the carbon monoxide, LP-Gas and smoke detectors for proper operation.
- Check that the monitor panel is functioning properly.
- Inspect the 120 Volt electrical system which includes the power cord, inverter/converter all outlets and exposed wiring.



**NOTE: Prepare the generator for operation following the instructions in the Generator Manual.**

- Start and run the generator.
- Confirm that the batteries are charging. Operate the 120 Volt appliances and air conditioners. If an electrical item or appliance is not functioning properly, contact the dealer or an authorized service center to have it evaluated.
- Have a qualified technician inspect the LP-Gas system and perform an LP-Gas leak test. The leak test should also include an LP-Gas regulator adjustment (if needed). The test can also verify if the regulator is faulty and should be replaced. Have the LP-Gas tank inspected.
- Operate each LP-Gas appliance. Observe all burner/pilot flames for proper color and size.
- Inspect and clean the interior.
- Check the sealant around all roof and body seams and windows. Reseal if necessary.
- Lubricate all the exterior locks, hinges and latches with a graphite lubricant.
- Check the windshield wiper blade condition. Check the wiper/washer operation.
- Wash and wax the exterior. Inspect the body for scratches or other damage; touch up or repair as necessary. Flush the underside thoroughly.
- Run through the operational checks for steering, brakes, engine and transmission. Operate the motorhome slowly during these checks to allow sufficient circulation of fluids and resetting of the components.
- If desired, have the dealer or repair center double check preparation to make any necessary adjustments and/or correct defects.

# SAHARA

## SECTION 4 APPLIANCES

- INTRODUCTION • 113**
- REFRIGERATOR • 113**
  - Operation Specifics • 114*
  - Refrigerator Controls • 114*
  - Control Panel - Two Door • 115*
  - Control Panel - Four Door (Optional) • 116*
  - Ice Maker Operation (Optional) • 117*
  - Doors • 117*
  - Alarm • 118*
  - Service • 118*
  - Cooling Unit Fans (Four Door Models) • 118*
  - Storage • 119*
- MICROWAVE OVEN • 119**
  - Operation • 122*
  - Microwave Cooking • 124*
  - Convection Cooking • 125*
  - Tips • 126*
  - Care & Cleaning • 127*
- COOKTOP RANGE/OVEN • 127**
  - Operation • 128*
  - Lighting Top Burners • 128*
  - Burner Grate • 128*
  - Tips • 129*
  - Cleaning & Maintenance • 129*
- COOKTOP RANGE (Opt.) • 130**
  - Lighting Oven Pilot • 130*
- WALL THERMOSTAT • 131**
- AIR CONDITIONER - ROOF • 131**
  - Operation • 131*
- FURNACE • 132**
  - Operation • 132*
  - Tips • 133*
  - If Furnace Fails to Light • 134*
- WATER HEATER • 134**
  - Before Using the Water Heater • 135*
  - Operation • 135*
  - Pressure - Temperature Relief Valve • 137*
  - Burner Compartment • 137*
  - Water Heater Bypass System • 138*
  - Tips • 138*
  - Draining & Storage • 139*
  - Troubleshooting • 139*
- WASHER/DRYER PREPARED • 139**
- WASHER/DRYER (Opt.) • 140**
  - Operating Instructions • 140*
  - Cleaning the Drain Screen • 141*
  - Cleaning the Washer/Dryer • 141*
  - Winterizing the Washer/Dryer • 141*







## INTRODUCTION

This section covers operation and care of various appliances found in the motorhome. The motorhome is equipped with a refrigerator, cooktop range, microwave, furnace, water heater, roof air conditioner and several optional appliances. Many of these appliances operate on AC or DC current, LP-Gas or a combination of all three.



**Detailed information with CAUTION or WARNING instructions for the various appliances, other than what is found in this section, can be found in the manufacturer's manual.**



**WARNING: Before entering any type of refueling station make sure all LP-Gas operated appliances are off. Most LP-Gas appliances used in recreational vehicles are vented to the outside. When parked close to a gasoline pump it is possible for fuel vapors to enter this type of appliance and ignite, resulting in an explosion or fire. Carbon monoxide gas may cause nausea, fainting or death. Operating an LP-Gas appliance with inadequate ventilation or partial blockage of the flue can result in carbon monoxide poisoning. Do not store flammable liquids such as lighter fluid, gasoline or propane in the outside refrigerator compartment.**

The refrigerator in the motorhome operates on a different principle than a standard household refrigerator. Knowing these differences should answer questions or solve problems that may arise. A standard household refrigerator uses a different type of refrigerant. In a household refrigerator, a compressor pumps refrigerant vapor into a condenser where the heat from the refrigerant dissipates and the vapors condense to a liquid. The liquid refrigerant pumps through a metered orifice or capillary tube at the evaporator. At this time, the refrigerant changes from liquid to a vapor. This change cools the evaporator. Air blows across the evaporator and into the interior of the refrigerator. This system is efficient as long as 120 Volts AC is available.

The motorhome refrigerator uses a combination of fluids and gas for refrigeration: ammonia, water, sodium chromate and hydrogen gas. The cooling unit is pressurized to approximately 350 psi. The chemicals are heated to a gaseous state, which rise to the top of the cooling unit into a condenser where it forms droplets as it cools. As the vapor condenses, it "extracts or absorbs" heat from inside the refrigerator. Using gravity, the droplets return through the absorber coils to the absorber vessel to start the process again. To ensure longevity and proper operation of the cooling unit follow the specific instructions for use and care. With proper care and maintenance, the refrigerator should provide years of trouble-free service.

## REFRIGERATOR

## **Operation Specifics**

- The refrigerator operates from LP-Gas or 120 Volts AC electric.
- DC Voltage must be no higher than 15.4 Volts DC or lower than 10.5 Volts DC.
- AC voltage must be no higher than 132 Volts AC or lower than 108 Volts AC.
- It is important to operate the refrigerator only when level. Level the refrigerator (from front view) within 3° side to side and 6° front to back. Use a torpedo or bulls eye (fence post) level. Place the level on the freezer plate. The level should be within the circle by a half of a bubble. Generally, this is within comfortable living conditions.



**NOTE: Operating the refrigerator "off level" separates the chemicals that crystallize and block the circulation action of the cooling unit. Damage is cumulative and irreversible.**



**WARNING: Do not use the refrigerator if there is an ammonia smell inside or outside of the refrigerator, or if a yellowish substance appears inside or at the outside access compartment. This can be an indication of a refrigerant leak. Contact an authorized repair facility.**



**NOTE: To reduce the possibility of food spoilage, keep the interior box temperature at or below 54° F. The refrigerator will consume more energy to maintain low temperature, especially in hot, humid climates. Lower temperature may also lead to quicker frost build-up.**

---

## **Refrigerator Controls**

**In order for the refrigerator to operate:**

- The house batteries must be charged.
- The LP-Gas valve must be on.
- The water valve must be on (icemaker option only).
- The refrigerator AC cord plugged in (located in outside refrigerator access door).

If the controls do not light up check the house batteries charge status or see if the 12 Volt wires are plugged into the refrigerator's circuit board (outside in refrigerator access door).

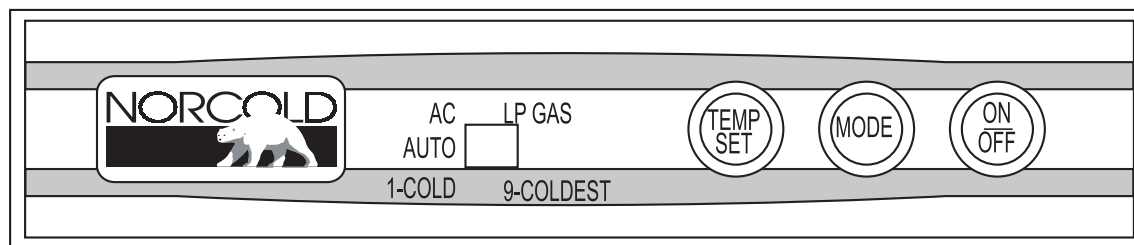
**Control Panel  
- Two Door**

030908

- **ON/OFF Button** - Turns the refrigerator on or off.
  - Push the **ON/OFF** button to start the refrigerator in Auto mode.
  - Push and hold the **ON/OFF** button for two seconds to shut it off.
- **TEMP SET Button** - Adjusts the temperature.
  - To adjust push and hold the **TEMP SET** button.
  - Number "9" is the coldest setting.
- **MODE Button** - Controls the operation mode of the refrigerator.
  - Push and hold the **MODE** button to select between Automatic AU, AC or LP operation.

**Manual Mode:**

When one of the two manual modes is selected:

1. **AC** = The refrigerator is operating on AC electric.
2. **LP** = The refrigerator is operating on LP-Gas.

If the LP-Gas does not ignite within 30 seconds, the control changes to a different energy source or the gas safety valve closes and F displays. Turn the refrigerator off then back on. If the gas does not ignite after several attempts, consult your dealer or authorized Norcold service center.

**Automatic Mode:**

The refrigerator selects AC power over LP-Gas in Auto mode. The controls select the energy source in this sequence.

1. When 120 Volts AC is available "AU AC" flashes in the display. This indicates the refrigerator is operating on AC electric. After ten seconds, the "AU AC" goes off and only a power indicator remains.
2. If 120 Volts AC is not available, "AU LP" flashes in the display. This means the refrigerator is operating on LP-Gas.
3. After the refrigerator is operating, press the **TEMP SET** button and set the desired temperature.

**Control Panel -  
Four Door  
(Optional)**

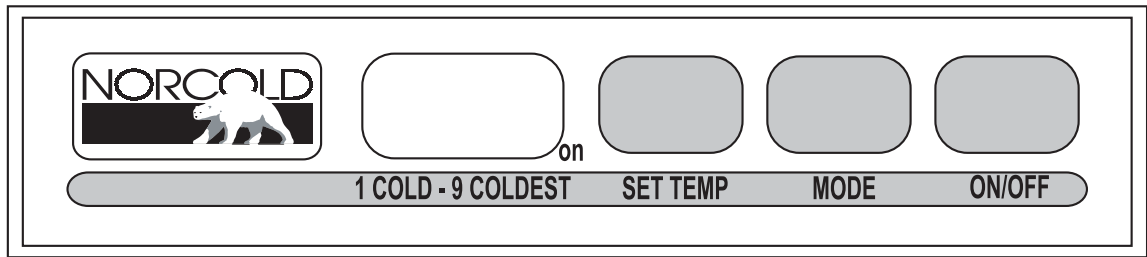

The Refrigerator Control Panel requires 12 Volt DC to operate.

030864

- **ON/OFF Button** - Turns the refrigerator on or off.
  - Push the **ON/OFF** button to start the refrigerator in Auto mode.
  - Push and hold the **ON/OFF** button for two seconds to shut it off.
- **LED Display** - This screen is used for mode, temperature and fault code display.
- **MODE Button** - Controls the operation mode of the refrigerator.
  - Push and hold the **MODE** button to select between Automatic AU, AC or LP operation.
- **TEMP SET Button** - Adjusts the temperature.
  - To adjust push and hold the **TEMP SET** button.
  - Number "9" is the coldest setting.

**Manual Mode:**

When one of the two manual modes is selected:

1. **AC** = The refrigerator is operating on AC electric.
2. **LP** = The refrigerator is operating on LP-Gas.

**Automatic Mode:**

This feature selects AC over LP-Gas operation. If AC discontinues the alarm sounds and the refrigerator switches to LP-Gas operation. If the refrigerator fails to light, the alarm sounds and a code displays.

- Press and hold the **MODE** button until **AUTO** displays, release the button.
- Press and hold the **TEMP SET** button until the desired temperature displays, release button.
- In **AUTO** mode, AC or LP will remain lit for 10 seconds or when a mode has changed.

If the LP-Gas does not ignite within 30 seconds, the control changes to a different energy source or the gas safety valve closes and F displays. Turn the refrigerator off then back on. If the gas does not ignite after several attempts consult your dealer or authorized Norcold service center.

**Tips**

- Cool items first, if possible, before putting them into the refrigerator.
- Keep the doors shut. Think about what you want before opening the doors.
- Allow the refrigerator 24 hours of operation before actual use to help it get a "head start" with the refrigeration process.
- A box of open baking soda will help absorb food odors.

---

The icemaker works from 120 Volts AC only. The icemaker functions only after the freezer temperature is low enough. City water or the water pump must be on and the valve for the water supply line to the icemaker must be on.

**Ice Maker  
(Optional)**

- Pull the metal arm (bail) down to turn the icemaker on.
- Push the arm up to turn the icemaker off.



**NOTE: If the icemaker is in operation while the motorhome is in motion, water may spill out of the ice tray. Raise the icemaker arm to stop ice production while in transit. Do not use the first one or two trays of ice if the refrigerator has been in storage. Ice cubes may have contaminants. Do not operate the icemaker without water pressure supplied to the refrigerator. This can cause damage to the ice maker assembly.**

---

The refrigerator doors use a positive latch that secures the door with a "click" to prevent the door from opening while traveling. The doors use a heating element located in the flapper on the left door (four-door model) or in the door (two-door model). The heating element activates when operating the refrigerator in any mode to help prevent moisture accumulation in high humidity conditions.

**Doors**

When storing the motorhome, the refrigerator doors have a storage position that locks the doors partially open. This will help reduce odor from mold and bacteria. A completely sealed refrigerator in storage is a perfect environment for mold and bacteria to grow.

To use the storage feature, partially open doors and slide tab into the cut-out of the strike plate.

## Alarm

The refrigerator uses an audible alarm that will sound for the following reasons:

1. DC or AC voltage is higher or lower than allowed.
2. Refrigerator is set to Auto and 120 Volts AC is discontinued.
3. The refrigerator fails to light on LP-Gas or fails to light after a period of operation.
4. Door is open longer than two minutes.
5. The circuit board detects a failure displaying a code.



**NOTE: If the alarm sounds, note the code in the LED display and turn the refrigerator off to silence the alarm.**



**Refer to the manufacturer's manual for the list of codes and their meanings.**



**WARNING: Make sure all flames are extinguished and the LP-Gas valve is off before refueling. LP-Gas and gasoline are highly flammable which can ignite, resulting in an explosion, fire or death. Many states have passed laws regarding having the LP-Gas valve open while traveling. Know the laws for the particular state in which you are traveling.**

---

## Service

The LP-Gas function of the refrigerator and LP-Gas pressure will need servicing yearly, depending on use. Over time, the BTU rating of the flame can change, affecting the refrigerator's performance. Ambient temperature and humidity can also affect performance and function. The BTU rating lowers when operating on LP-Gas at an altitude higher than 5,500 feet. This affects the refrigerator's performance. If possible, switch mode operation to AC while at a higher altitude.

---

## Cooling Unit Fans (Four Door Models)

The cooling unit is equipped with a pair of cooling fans to help pass air across the cooling unit. These fans start automatically and are audible when in operation.

**Storage**

- Turn the refrigerator off and remove all items. Leave the drip tray under the cooling fins.
- Shorten defrost time by using trays of warm water. Do not use a heating gun, hair dryer or sharp objects to remove frost as these can damage the interior or cooling unit.
- Wash the interior using mild spray cleansers or a solution of liquid dish detergent and warm water. Do not use scouring pads or abrasive cleansers as these can damage the interior finish.
- Rinse with a solution of baking soda and water. Dry with a clean cloth.
- Lock the doors open.



**CAUTION: When defrosting, do not use a hot air blower. Permanent damage could result to plastic parts. Do not use a knife, ice pick or any other sharp instrument to remove ice from the freezer as they can puncture the system.**

The microwave oven is operated from 120 Volt AC supplied by shore power, the generator or the inverter. Microwaves heat food using sound waves generated at a very high frequency (2,450 MHZ) to agitate the water molecules inside the item being heated. The higher the water content is to solids, the faster the response or the shorter the cooking time. Inside the microwave is a turntable that rotates when the microwave is operating. This will help heat the food evenly. The turntable can be turned off if a baking dish or other large item is used. The microwave is designed to sit over a range or cooktop. When cooking from the cooktop use the microwave's two speed ventilation fan. The fan draws air in from the bottom of the microwave through a pair of grease filters then discharges the filtered air out through a charcoal filter at the top. The ventilation fan is controlled by a thermostat and activates automatically from heat produced by the cooktop.

The microwave offers many different features. Some include varied cooking times with different power settings: automatic sensor cooking, a kitchen timer, metric to American conversion chart (which includes temperature and weight), on screen programming help, childproof lockout and auto defrost cycles. The screen can display one of three different languages.

After placing the food in a suitable container, open the oven door and put it on the glass tray. The glass tray and roller guide must always be in place during cooking. Ensure the door is firmly closed before use.

**MICROWAVE  
OVEN**

**Microwave Tips:**

- Turn the oven off before cleaning.
- Keep the inside of the oven clean. When food spatters or spilled liquids adhere to oven walls, wipe with a damp cloth. Mild detergent may be used if the oven gets dirty. The use of a harsh detergent or abrasive cleaner is not recommended.
- Clean the outside oven surface with soap and water. Wipe away any residue using a damp cloth. Dry with a soft cloth. To prevent damage to the operating parts inside the oven, do not allow water to seep into the ventilation openings.
- If the control panel becomes wet, clean with a soft, dry cloth. Do not use harsh detergents or abrasives on the control panel.
- If steam accumulates inside or around the outside of the oven door, wipe it away with a soft cloth. This may occur when the microwave oven is operated under high humidity conditions and in no way indicates a malfunction of the unit.
- It is occasionally necessary to remove the glass tray for cleaning. Wash the tray in warm sudsy water or in a dishwasher.
- The roller guide and oven cavity floor should be cleaned regularly to avoid excessive noise. Simply wipe the bottom surface of the oven with mild detergent water or window cleaner and then dry. The roller guide may be washed in mild sudsy water.



**NOTE: The microwave is for food preparation only. Do not use the microwave to dry clothes, newspapers, shoes or other items.**

**Microwave Facts:**

One of the most useful documents for the microwave is the operations manual, located in the owner's information file box. Read it carefully and keep it for reference. Another useful item is a microwave cookbook. Many will contain information about cooking principles, techniques, hints and recipes. Ensure food is in the microwave during operation to absorb the microwave energy. The magnetron, cycling on and off, may be heard for power levels less than 100%.

Condensation is a normal occurrence in microwave cooking. The moisture within foods and the room humidity will influence how much moisture condenses in the microwave. Covered foods will not usually produce as much condensation as foods that are not covered.



**About Cooking:**

- Food should be arranged with the thickest area towards the outside of the dish.
- Monitor cooking times. Use the shortest amount of time required for cooking and add time as needed. For popcorn, follow product instructions and carefully monitor for the duration of popping time.
- Cover the food while cooking to prevent splatter and reduce condensation.
- Stir the food from the outside of the dish to the center, once or twice, between cooking.
- Turn food over during cooking to speed cooking times. Large food items should be turned at least once during cooking time.
- Use standing times to prevent overcooking. Covered food will continue to cook after it is removed from the microwave oven.
- Check for indications that the food is thoroughly cooked.
  - Food is steaming throughout, not just around the edges.
  - Poultry thigh joints come apart and move easily.
  - Meat or poultry is not pink in color.
  - Fish is opaque and flakes easily with a fork.
  - Center bottom of the dish is very hot to touch.

A meat thermometer is the best way to ensure that the food is cooked. The meat thermometer should be inserted into the thickest part of the meat, away from bone or fat. Most food should range between 160° F to 180° F. Never leave the thermometer in during cooking as it can shatter.

FOOD	DO	DO NOT
Eggs, Sausages, Fruits & Vegetables	<ul style="list-style-type: none"> <li>• Puncture egg yolks before cooking to prevent bursting.</li> <li>• Pierce skins of potatoes, apples, squash, hot dogs &amp; sausages to allow steam to escape.</li> </ul>	<ul style="list-style-type: none"> <li>• Cook eggs in shells.</li> <li>• Reheat whole eggs.</li> </ul>
Popcorn	<ul style="list-style-type: none"> <li>• Use specially bagged popcorn for use in the microwave.</li> <li>• Remove popcorn when popping slows to 1 or 2 seconds in between pops. Use the POPCORN setting.</li> </ul>	<ul style="list-style-type: none"> <li>• Pop popcorn in regular brown bags or glass bowls.</li> <li>• Exceed maximum time on popcorn package.</li> </ul>
Baby Food	<ul style="list-style-type: none"> <li>• Transfer baby food to small dish &amp; heat carefully. Stir often. Check temperature before serving.</li> </ul>	<ul style="list-style-type: none"> <li>• Heat disposable bottles</li> <li>• Heat rubber nipple.</li> <li>• Heat baby food in original jar.</li> </ul>
General	<ul style="list-style-type: none"> <li>• Cut filled baked goods after heating to release steam.</li> <li>• Stir liquids before and after heating to avoid boiling over.</li> <li>• Use deep bowls for cooking liquids or cereals to avoid boiling out of the container.</li> </ul>	<ul style="list-style-type: none"> <li>• Heat or cook in closed jars or air-tight containers.</li> <li>• Use for Canning. Cooking and heating may not destroy bacteria.</li> <li>• Deep fat fry.</li> <li>• Dry wood, gourds, herbs or wet paper.</li> </ul>

microwave food chart

### **Microwave Cooking Safety:**

- Always use pot holder to prevent burns when handling utensils that are in contact with hot food. Enough heat can transfer from food through utensils to cause skin burns.
- Stay near microwave when cooking and check frequently during cooking to prevent overcooking.
- Never use the cavity as a storage area for cookbooks or other items.
- Avoid steam burns by directing steam away from face and hands.

---

## **Operation**

The microwave/convection oven operates from 120 Volt AC supplied by shore power. The microwave has a power output of 850 watts and a convection heater output of 1,400 watts. Oven capacity is 1.1 cubic feet.

The microwave/convection oven has the ability to cook food with heat like an electric oven or preheat the oven with heat and cook with microwaves. Other features include the ability to cook with microwaves and convection at the same time, sensor cooking and a built-in broiler. A brief overview of these features may aid in the operation of the microwave/convection oven.



**NOTE: The microwave is for food preparation only. Do not use the microwave to dry clothes, newspaper, shoes or other items.**

### **Safety Lock:**

The microwave comes with a safety lock feature. This feature prevents the oven from operating accidentally. To use this feature:

- Press the **CUSTOM HELP** pad.
- Press the **1** pad.
- Press the **START/TOUCH-ON** pad.

The oven is now locked. If any button is pressed the word **LOCK** appears on the screen. The fan and hood light is still operational with the Safety Lock feature on. To return the oven to normal operation:

- Press the **CUSTOM HELP** pad.
- Press the **1** pad.
- Press the **START/TOUCH-ON** pad. The oven will resume normal operation.

### **Setting The Clock:**

- Press the **STOP/CLEAR** pad.
- Press the **CLOCK** pad.
- Enter correct time in sequence using the number pads.
- Press the **CLOCK** pad to begin time.



**NOTE: The clock is a 12 hour clock only.**

**Kitchen Timer:**

- Press the **KITCHEN TIMER** pad.
- Using the number pads enter minutes and seconds, or 00 if no seconds.
- Press the **START/TOUCH-ON** pad to begin timer. Timer end will be signaled by one long beep.

**Hood Light:**

To turn the hood light on or off touch the **LIGHT** button.

**Ventilation Fan:**

Press the **FAN HI/LO** button once for high, twice for low and three times for off.

**Press the STOP/CLEAR pad to:**

- Erase, if you make a mistake during programming.
- Cancel the kitchen timer.
- Stop the oven temporarily during cooking.  
(Press the **START/TOUCH-ON** pad to resume.)
- Return the time of day to the display.
- Cancel a program during cooking (touch the pad twice).

**Turntable On/Off:**

- Press **TURNTABLE ON/OFF** pad to stop or start the turntable.
- Enter the cook time desired minutes and seconds.
- Enter power level desired.
- Press the **START/TOUCH-ON** pad.

**Microwave - Timed Cooking:**

The maximum amount of cooking time is 99 minutes and 99 seconds.

Be sure to enter minutes and seconds. If seconds are not desired enter 00.



**WARNING: If a fire flares up when using the cooktop turn off the ventilation fan. The fan may spread the flame. If the ventilation fan has started automatically from a heated cooktop it can not be manually turned off. Turn off the microwave AC circuit breaker to prevent the flame from getting up into the microwave and spreading the fire.**



**NOTE: When cooking in convection mode try to avoid using the inverter as the AC power source due to the high rate of battery consumption.**

## **Microwave Cooking**

Press and hold the **START/TOUCH-ON**. The microwave pad operates at 100% power until the pad is released. This mode can be used for up to three minutes and up to three consecutive cycles.

### **One Minute Cook Times:**

Press the **MINUTE PLUS** pad if one minute at full power is desired or to add one minute intervals to cooking time. The **MINUTE PLUS** pad must be pressed within one minute of closing the door, or during selected cooking time.

For safety the **MINUTE PLUS** feature will lock out if there is no microwave activity within one minute of closing the door. Use the **START/TOUCH-ON** pad to reset the one minute safety period.

### **Microwave Cooking:**

To use 100% power, enter cook time by pressing the number pads. Press the **START/TOUCH-ON** pad to begin cook time. To use settings lower than 100% power, use the number pads to enter desired cooking time. Press the **POWER LEVEL** pad. Use the number pad to select desired power level. Press the **START/TOUCH-ON** pad to begin cook time.

### **Multiple Sequence Cooking:**

If sequential cooking times with varied power levels are desired, press the **POWER LEVEL** pad and select desired power level. Use the number pad to enter cook time for the first interval. Press **POWER LEVEL** pad again, select desired power level, then enter cook time for the next time period. Press the **START/TOUCH-ON** pad to begin sequential cooking. The microwave can hold up to four sequential cook time periods. If full power is desired in any of the time periods, skip the power level step and 100% power is automatically selected.

### **Keep Warm:**

Press the **KEEP WARM** pad during cooking time to automatically keep food warm for up to 30 minutes after cooking time has expired. To use this feature after cooking time has expired, or after the food has been removed, place the food back into oven and press the **KEEP WARM** pad.

### **Defrosting:**

Defrosting can be done on manual time selection or use the microwave's CompuDefrost.

### **Manual Defrost:**

Press the **POWER LEVEL** pad. Select number 3 for defrost power. Enter desired defrost time. Be sure to stir or break food apart at regular intervals.

**CompuDefrost:**

The microwave has automated defrost programs for different foods and weights. Press the **CompuDefrost** pad to enter this mode. Press **CompuDefrost** again to select between ground meat, steak or chicken. Use number pads to enter weight of food being defrosted. Press **START/TOUCH-ON** to begin defrost cycle.

**Sensor Cooking:**

The microwave has electronic sensors that sense moisture or humidity given off by the food during the cooking process. Electronic sensors will be affected if room temperature exceeds 95° F. To adjust the sensor cooking mode to allow for more or less cooking time, press the **SENSOR COOK** pad. Press the **POWER LEVEL** pad once to increase cooking time or twice to decrease cook time.

To use the sensor cooking mode, press the **SENSOR COOK** pad. Select the number or food desired from the library listed adjacent to the **SENSOR COOK** pad. Press the **START/TOUCH-ON** pad to begin sensor cooking.

The interior of the microwave produces heat just as in a regular oven. The convection cooking mode has special options such as a broil mode, the ability to preheat oven by convection and use of microwaves to complete cooking or to preheat.

**Convection Cooking**

**NOTE: When using the convection oven feature, leave the turntable in place and do not restrict the rotation. This can damage the microwave.**

**Cooking with Convection:**

Press the **CONVEC** pad. Press the numbered pad with the desired cooking temperature. Press the numbered pads for desired cooking time. Press the **START/TOUCH-ON** pad to begin convection cooking.

**Manual Broiling:**

The Manual Broiling temperature is automatically preset to 450° F. Only the cooking time can be adjusted.

To use the broiler, press the **BROIL** pad. Enter amount of cooking time. Press the **START/TOUCH-ON** pad to begin preheating the oven. Four beeps will signal the end of the preheat cycle. Food can now be placed into the oven.

**CompuBroil:**

The CompuBroil cooking method has programs preset for common foods like hamburgers, steaks, chicken and fish. Temperature and time are preset depending on the food quantity. The amount of cooking time can be adjusted to fit particular needs. The **POWER LEVEL** pad will vary the preset cooking time. **Press once for more time and twice for less time.**

To use the **CompuBroil** feature: Press the **CompuBroil** pad and select the food number from the food library next to the CompuBroil pad. Enter the number of pieces being broiled. Press the **START/TOUCH-ON** pad to begin the preheat cycle. A series of four beeps signal the end of preheat cycle.

**Automatic Mix Cooking:**

This method combines both the convection oven and microwave at the same time. The microwave uses 30% power on **HIGH/MIX** and 10% power on **LO/MIX** while in this mode. The convection temperature can be changed from 100° F to 450° F. The default convection temperature is 325° F for both **HIGH/ MIX** and **LO/MIX**.

To use this feature: Select either **HIGH/MIX** or **LOW/MIX** and use the number pads to enter cooking time. Press the **START/TOUCH-ON** pad to begin the mixed cooking cycle.

**CompuRoast or CompuBake:**

These features can be used for food items ranging from pastries and cakes to roasts, chicken and pork. The temperature is preset for both functions. Only the cook times can be tailored for individual preference by entering into either the **CompuRoast** or the **CompuBake** mode. Press the **POWER LEVEL** pad once for more cooking time and twice for less cooking time.

To use either function: Press the desired pad, enter the food type from list next to the mode used and enter the food type being cooked by using the number pad.

To use **CompuBake**: Press the **START/TOUCH-ON** pad to begin the preheat cycle.

To use **CompuRoast**: Enter the weight of item using the number pads. Press the **START/TOUCH-ON** pad to begin the preheat cycle. Four beeps will signal the end of the preheat cycle and the oven is now ready.

---

**Tips**

- Check the type of cookware being used to see if it is microwave or oven safe depending on the type of cooking being done.
- Gold paint or glaze may contain a trace amount of gold which is electrically conductive and not compatible for microwave. Hand-painted china commonly contains traces of metal.
- To test utensil for microwave compatibility place it in the microwave with an 8 oz. plastic cup of water. Set the microwave at full power for one minute. Carefully feel the utensil. The entire utensil should be cool to the touch.
- Cover food with a paper towel or upside-down plate to help keep food spattering to a minimum. Place a paper towel on the turntable to keep clean-up at a minimum. Use only microwave-safe paper towels.
- Clean all spills or spatters before they dry.

- Food odors may linger inside oven. To help eliminate odors, combine the juice and the peel from one lemon, several whole cloves and 8 oz. of water into a two cup bowl. Place in oven on high power, bring to a boil for several minutes. Let cool in the oven for several minutes.
- Some food wrappers may be foil lined. Check the wrapping carefully before cooking or heating. A small amount of foil is acceptable if it is not wrinkled or near the sides of the microwave.
- If the microwave screen is not lit, plug another electrical appliance into the same outlet the microwave was plugged in to verify AC power is present. If the test item works, contact an appliance repair facility to have the microwave checked.

The exterior of the microwave is plastic and metal. The interior is metal. Do not use a scouring pad, harsh or abrasive cleanser, chemical cleaners or petroleum based thinners as these can damage the finish. Use mild soap and water with a damp cloth or paper towel to remove most stains or spills. When cleaning the touch pad open the door to prevent accidental operation. Use mild soap and water with a soft cloth. Avoid using excess amounts of water on the touch pad. The turntable plate and oven racks are dishwasher safe.

### Care & Cleaning

#### Grease Filters:

Do not operate the oven without the grease filters in place. This can damage the microwave. Grease filters should be cleaned at least once a month. To remove the filters, use the pull tab to slide the filter to the end of the opening and tip down. Soak the filters in the sink or in a dishpan filled with hot water and detergent.

- Do not use ammonia or other alkali based products. They may darken the filter material.
- Agitate the filter. Use a scrub brush to remove caked on grease.
- Rinse the filter thoroughly and shake it dry. Place the filter back into the opening, tip it upward and slide it to the end of the opening. Lock it in place. Be careful not to kink or warp the filter upon installation.

The cooktop uses LP-Gas only as a fuel source. The burners use a piezo type igniter. The cooktop should be used for cooking purposes only and not as a heating source. When the burner valve is opened the fuel source flows through the valve into the mixture tube. The fuel passes by a hole or venturi in the mixture tube, which draws air in with the fuel for a proper fuel/air ratio. The flame should have a blue appearance with a lighter blue defined flame at the burner head. A yellow flame or yellow tips indicate a rich fuel mixture, which can leave a black color or carbon on the bottom of a pot or pan.

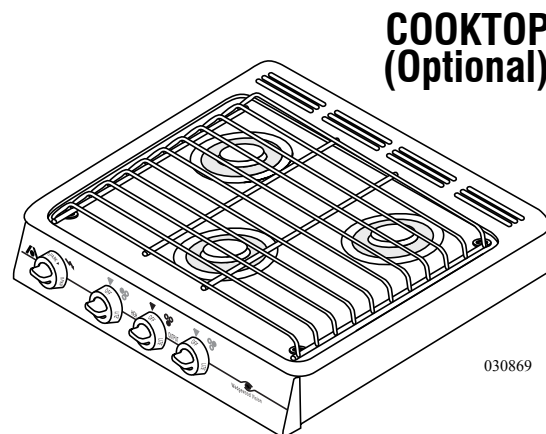

## Operation

**The cooktop will operate when the following conditions have been met:**

1. The LP-Gas valve on the LP tank is open.
2. The house battery cut-off switch is on.

To use the cooktop open the desired burner valve and rotate the igniter knob, clockwise, at the left hand side of the stove.

Before cooking on the range top the cover must be in full upright and folded position. Push the cover toward the outside wall to prevent it from falling onto the range top during cooking.

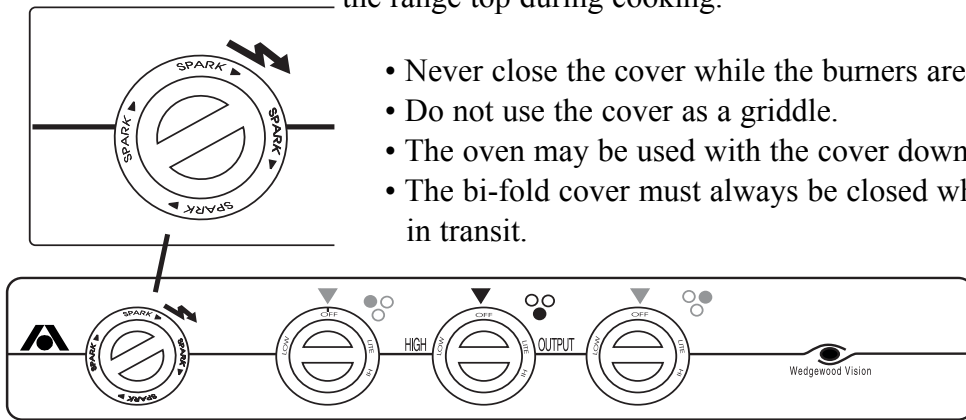

- Never close the cover while the burners are in use.
- Do not use the cover as a griddle.
- The oven may be used with the cover down.
- The bi-fold cover must always be closed when the motorhome is in transit.

030870 modified



**WARNING: Do not the heat motorhome interior with the range or oven. Gas combustion consumes oxygen inside the motorhome. Carbon Monoxide is an odorless, colorless and highly poisonous gas.**

## Lighting Top Burners

- Turn the appropriate burner knob counterclockwise to **ON** or **LITE**. Do not attempt to light more than one burner at a time.
- Turn the **SPARK** knob clockwise one click. If the burner fails to light, continue turning the **SPARK** knob clockwise until the burner lights.
- Turn the burner knob clockwise to **OFF**.



**WARNING: Top cover must be open when the cooking surface is in operation. Do not cover the oven vent openings while the oven is in operation.**

## Burner Grate

The burner grate is attached to the cooktop cover by two spring clips located on the underside of the cooktop cover. The burner grate can be separated from the cooktop cover for cleaning purposes. Place a towel down onto the countertop next to the cooktop. Lift the cooktop cover up by the front corners, just high enough to clear the top of the burners. Pull the cooktop cover toward the front of the cooktop and lift it away. Place the cooktop cover upside down onto the towel. Squeeze both of the grate spring clips to remove the grate from cooktop cover.





**WARNING: If you smell gas, extinguish all open flames and turn off the main gas supply. Liquid propane is highly volatile, highly explosive and extremely dangerous. Explosion, fire, property damage, injury or death can result. Propane is a “heavy” gas and will lay on the floor and “hide” in corners. Open all windows and doors. Do not touch any electrical switches. They may cause a spark which can ignite. Contact a qualified service center to have the problem correctly diagnosed and repaired before resuming operation.**

1. A yellow flame is an indication of incorrect fuel/air ratio. Lowered BTU output and carbon build up can occur.
2. When cooking at an altitude above 5,000 feet the flame may change appearance and the flame BTU output will be lowered. Allow extra cooking time.
3. Do not allow the tips of the flame to extend beyond pan or pot edge. When this occurs heat is wasted and possibility of injury increases.
4. Remove the cooktop cover to help keep the underside of the cooktop clean. Place strips of aluminum foil on the cooktop floor pan and under burners. Do not restrict air flow of mixture tubes.
5. Pre-heat the oven for 10 minutes prior to use.

### **Tips**

#### **Cleaning Tips:**

- Clean all surfaces as soon as possible after boil overs or spillovers.
- Use warm soapy water to clean the burner grates, cooktops, painted surfaces, porcelain surfaces, stainless steel surfaces and plastic items on the range or cooktop. Grit or acid-type cleaners may ruin the surface.
- Use only non-abrasive plastic scrubbing pads.
- Do not allow foods containing acids (such as lemon or tomato juice, or vinegar) to remain on porcelain or painted surfaces. Acids may remove the glossy finish. Wipe up egg spills when cooktop is cool.
- Allow porcelain surfaces to cool before cleaning. Burns from the heated surface may occur or the cooktop porcelain can crack.

### **Cleaning & Maintenance**

Regular cleaning with a soft cloth and a warm detergent solution is generally enough to keep the cooktop clean. Wash, rinse and dry with a soft cloth. Thoroughly clean the cooktop when it is cool. Use a dry cloth or paper towel while the surface is warm to the touch to clean splatters or spills. Cleaning will be more difficult if spills bake on to the surface. Glass cleaner sprayed on a paper towel should be used for the cooktop surface. Do not spray glass cleaner directly on the surface. **DO NOT** use abrasive cleaners or steel wool. Harsh cleansers like bleach, ammonia and oven cleaner should NEVER be used. The surface burner grate and caps should be cleaned using the same guidelines as the cooktop surface.

### Porcelain Enamel:

Porcelain enamel is a type of glass fused on steel at a very high temperature. It is not extremely delicate but must be treated as glass. Sharp blows, radical surface temperature changes, etc., will cause enamel to chip or crack. Some foods such as vinegar, lemon juice, tomatoes and milk contain acids which can dull the finish of the enamel. To avoid dulling the finish, wipe up the spill before it is baked on. The surface is glass and must be given consideration when cleaning. Steel wool and coarse, gritty cleanser will scratch or mar the surface. Any gentle kitchen cleanser powder or grease cleaner will be suitable. For further information on care and maintenance of the porcelain, call “*Hopes Cultured Marble Polish*” at 800-325-4026.

## COOKTOP RANGE/OVEN

The cooktop range/oven is operated and maintained the same as the cooktop without the oven. This option allows for a wider variety in floor plans and provides more storage space.

### Lighting Oven Pilot

- Push in the oven control knob and rotate counterclockwise to **PILOT ON**.
- Light the oven pilot located near the back of the oven, under the broiler shelf and to the left of the oven burner.
- Set the oven control knob to **PILOT ON** to maintain pilot flame. The oven and broiler are now ready for operation. The oven pilot has been factory set and requires no further adjustment.
- To extinguish the oven pilot push in the oven control knob and rotate clockwise to **OFF**.

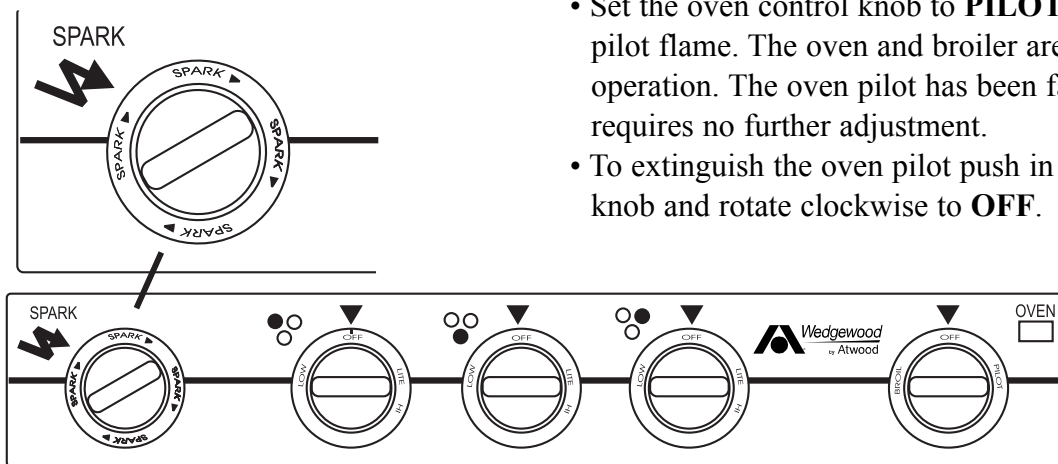

030828



**WARNING: Extinguish all pilots when refueling or traveling. Do not block vents in oven with cookware or other objects.**

**WALL  
THERMOSTAT**

The wall thermostat operates the HVAC (heating, ventilating and air conditioning) system. The thermostat, located in the living room, operates the front roof air conditioner functions as well as the LP-Gas furnace. The thermostat located in the bedroom controls the rear air conditioner functions and (if equipped) the bedroom furnace.

The roof air conditioners operate from 120 Volts AC only. Operation is controlled by a 12 Volt DC wall thermostat. The electronics in the wall thermostat send a signal to the roof air conditioner's circuit board. The circuit board controls the desired roof air conditioner functions. The refrigeration process in the roof air conditioner is primarily the same as the dash air conditioning or a household type refrigerator. It functions as an enclosed system. The refrigeration process repeats in a cycle. The refrigerant is drawn into the compressor where it is heated from compression. The high pressure vapor is sent to a condenser where the heat is expelled into the atmosphere. The vapor leaves the condenser as a high pressure liquid. This liquid is forced into a metered capillary tube and then into the evaporator or low side pressure. The refrigerant changes from liquid form to a vapor as the heat is extracted. The vapor is drawn back into the compressor to start the cycle again.

**AIR CONDITIONER  
- ROOF**

**NOTE: Air conditioning systems will freeze the moisture in the air depending on the humidity content. Under high humidity conditions it is recommended to leave the HIGH/LOW switch to the HIGH position.**

**The roof air conditioner will operate only when the following needs have been met:**

- 120 Volts AC from either shore power or the generator is supplied.
- The battery cut-off switch is in the **ON** position and house batteries are charged.

**Thermostat Operation:**

The thermostat operates the roof air conditioner and the furnace.

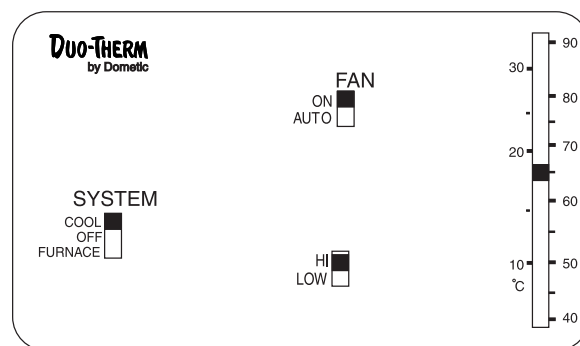
**Operation**

050235b

**Roof Air Operations:**

- **FAN ONLY** - Move the **FAN** switch to the **ON** position. Use the **HIGH** or **LOW** switch to set desired fan speed. Set the thermostat to desired temperature.
- **COOL** - Move the **SYSTEM** switch to **COOL**. Move the **FAN** switch to **ON**. Set the thermostat to the desired temperature. Use the **HIGH** or **LOW** switch to set desired fan speed.



**NOTE: The thermostat in the bedroom performs the same function as the living room thermostat. The FURNACE position on the bedroom thermostat is nonfunctional.**

**FURNACE**

The furnace and its related components are 12 Volt DC operated, using LP-Gas as the fuel source. Electronic circuitry (automatic ignition) is used to ignite the burner. The furnace uses outside air for the burner combustion and exhaust is expelled through the outside vent. Inside air is drawn into the furnace and blown across the internal heat exchanger. Heated air is then discharged through ducted hoses which can be run throughout the motorhome.

**Operation**

The furnace operates in the following manner: The wall thermostat sends a signal to the front roof air conditioner circuit board, which closes a relay. Closing a relay sends an electrical signal to the furnace to begin the ignition cycle. There is a small time delay before the blower motor begins. When the blower motor attains a predetermined speed it will close the air prover or sail switch. The sail switch sends the electrical signal through a high temperature protection switch, then to the automatic ignition circuit board. After the thermostat is satisfied, the gas valve closes and extinguishes the burner. The blower motor stops about two or three minutes after cool down.

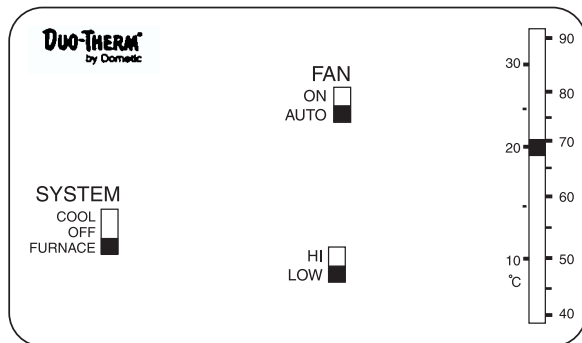

**The furnace will operate when the following conditions have been met:**

1. The LP-Gas valve on the LP tank is open and the LP-Gas valve at the furnace is on.
2. The house batteries in the motorhome are charged.
3. The battery cut-off switch at the entry door is in the **ON** position.

**Using the Furnace:**

1. Set the **SYSTEM** switch to **FURNACE**.
2. Set the **FAN** switch to **AUTO**.
3. Set desired temperature.



**WARNING: IF YOU SMELL GAS** extinguish all open flames and turn off the main gas supply. Liquid propane is a highly volatile, extremely dangerous gas. It can explode or ignite, which may result in property damage, injury or death. Propane is “heavy” and can “float” on the floor or “hide” in corners. Open all windows and doors. Do not touch electrical switches. They may spark, which can ignite. Keep all open flames, spark producing devices and smoking material out of the area. Contact a qualified service center to have the problem correctly diagnosed and repaired before resuming operation.



**CAUTION: Do not store any items or materials in the furnace area.** Restricted air flow may hamper furnace operation leading to failure and/or fire hazard.



**NOTE: The automatic ignition circuit board will attempt to light the burner three times before the ignition board will go into “lock-out.”** If the burner does not light the furnace blower motor will continue to run and the wall thermostat will have to be cycled off.



**NOTE: When washing the exterior of the motorhome,** avoid a direct stream of water into the outside furnace vents. This can damage the furnace.

- 
- After the motorhome has been removed from storage, operation of the furnace may produce a musty smell during the first couple of cycles.
  - Operating the furnace at an altitude above 5,000 feet reduces the BTU output due to air/fuel ratio.
  - The furnace will periodically need to be serviced by a qualified technician. If the furnace exhibits unusual symptoms or noises, or has an unusual odor when operating, have the furnace checked or serviced.

**Tips**

### **If the Furnace Fails to Light**

- Make sure the LP-Gas supply valve is open.
- Make sure the battery cut-off switch at the entry door is ON.
- The furnace will not light if the blower motor is not spinning to its specified speed. This may be due to a low house battery charge condition. Hook-up to shore power and start the generator or main engine to charge the batteries.
- If the blower motor does not spin and the necessary power requirements have been met, use a screwdriver or coin to open the furnace access panel outside of the motorhome. Make sure the ON/OFF switch is ON and the circuit breaker is pushed IN.



**WARNING: If you smell gas and the blower motor is spinning, do not attempt additional furnace operation. This may result in an explosion, fire or personal injury. Contact a qualified technician.**

---

## **WATER HEATER**

The water heater in the motorhome will heat water using LP-Gas. LP-Gas operation incorporates the use of an automatic ignition circuit board operated by 12 Volt DC. The water temperature is controlled by a thermostat. The temperature is preset by the water heater manufacturer. Water is pumped into the bottom of the water heater tank where it is heated and discharged out of the top of the tank upon usage. For easy winterization, the water heater is equipped with a temperature and pressure safety relief valve and a by-pass valve.



**NOTE: The automatic ignition circuit board will make three attempts to light the burner. If the burner does not light by the third attempt, the ignition circuit board will go into "lock-out." Cycling the on/off switch will reset the ignition board.**



**NOTE: Do not operate the water heater by either function without water in the water heater tank as this damages the thermostats and the electric heating element.**

**Before Using the  
Water Heater**

Before using the water heater, purge all trapped air from the water system. To purge the air and pressurize the system, fill the water heater tank by using the on board water pump or hooking up to city water. Check the tank for any obvious water leaks. When the system has pressurized, turn the hot and cold valves on for each water faucet, one at a time, inside and outside of the motorhome. Run each faucet until a steady stream of water with no air bubbles or air pockets is present. The water heater does not need to be operating during this process.



**WARNING: IF YOU SMELL GAS extinguish all open flames and turn off the main gas supply. Liquid propane is highly volatile, highly explosive and extremely dangerous. Explosion, fire, property damage, injury or death can result. Propane is a "heavy" gas and will lay on the floor and "hide" in corners. Open all windows and doors. Do not touch any electrical switches. They may cause a spark that can ignite. Evacuate the motorhome and shut off the LP valve. Contact a qualified service center to have the problem correctly diagnosed and repaired before resuming operation.**

**Water Heater Operations:**

- The LP-Gas valve on the LP tank is open.
- The battery cut-off switch at the entry door is **ON**.
- The house batteries are charged.
- Turn on the water heater switch at the monitor panel.

The ON/OFF switch controls the operating circuit. When the water heater is first turned on, the indicator lamp will briefly illuminate. If the water heater fails to light after three attempts, the water heater will “lock out” and the indicator lamp will illuminate.

The next portion of the operation is controlled by the direct spark ignition (DSI) system, as power is applied to the DSI board. The system will do the following:

1. The board has a timing circuit, which allows 12-18 seconds before ignition occurs.
2. The board will then apply current to the gas valve. At the same time, it produces a high-voltage current supply to the electrode to produce a spark at the burner.
3. The board will also confirm the presence of a flame.

**Operation**

The Thermostat-Limit controls the power to the module board. At 130° F, the thermostat will open shutting off the burner. If the thermostat fails, the limit switch will open, and requires manually resetting.

If the flame is not sensed after 6-9 seconds, the module board will try two more times and then go into lock-out. The flame sensing is through the spark wire.

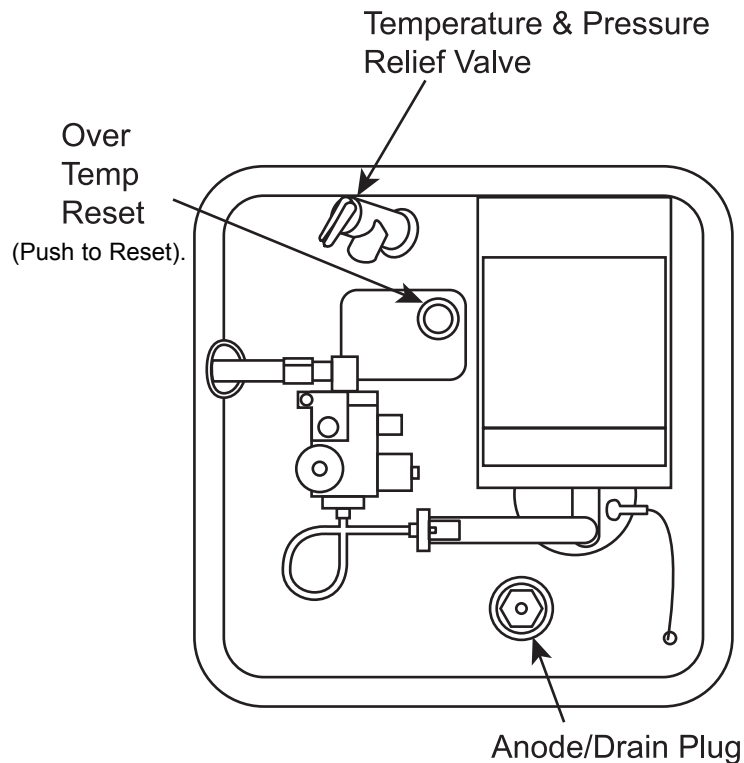

040424b

**LP-Gas Operations:**

- Make sure the LP-Gas is turned on.
- Turn the water heater switch to the ON position. The water heater will make an audible "roar" from the burner when ignited.
- The indicator light will illuminate briefly then go out when the water heater is lit. The indicator light will glow steady when the ignition cycle has gone into "lock-out."



**NOTE: It is recommended not to operate the water heater on LP-Gas while the motorhome is in transit.**



The water heater is equipped with a Pressure-Temperature relief valve. The water heater may discharge at the Pressure-Temperature relief valve during the heating cycle, due to thermal expansion of water. The Pressure-Temperature relief valve is designed to open if the water temperature within the heater reaches 210° F (98.8° C), or if the water heater pressure reaches 150 psi. This can be related to the fact the motorhome utilizes a closed system. A discharge is a normal occurrence and is not necessarily a faulty valve. The water heater has an internal air pocket to reduce the possibility of dripping or weeping. Eventually, the expansion of the water will absorb the air pocket. When this occurs, the air will have to be replaced utilizing the following procedure.

### **Pressure-Temperature Relief Valve**

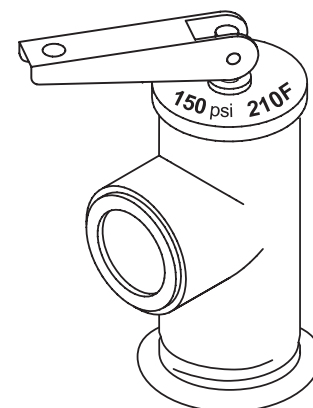

040463



**CAUTION:** Ensure the water heater storage tank is cool prior to making any check of the valve.

#### **Re-establishing the Air Pocket:**

**Step 1:** Turn off the water heater.

**Step 2:** Shut off the incoming water supply.

**Step 3:** Open the hot water line closest to the water heater.

**Step 4:** Pull the handle of the relief valve until the flow of water stops.

**Step 5:** Allow the relief valve to snap shut, close the hot faucet and turn on the water supply.

**Step 6:** Turn ON the water heater.

The air pocket is re-established and the process does not need to be repeated until the next discharge of water from the T&P valve. If the discharge does not stop, contact a qualified service center to evaluate the valve and make any required repairs.

### **Burner Compartment**

Periodically check the outside service compartment and screen (in the door) to ensure no foreign material has accumulated preventing the flow of combustion and ventilating air.



**INSPECTION:** Inspect the travel latch during the walk-around inspection.

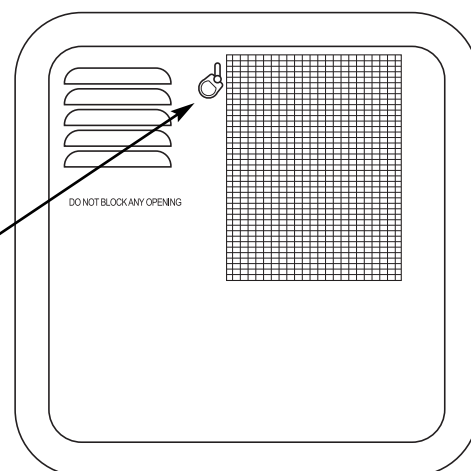

010720

## Water Heater Bypass System

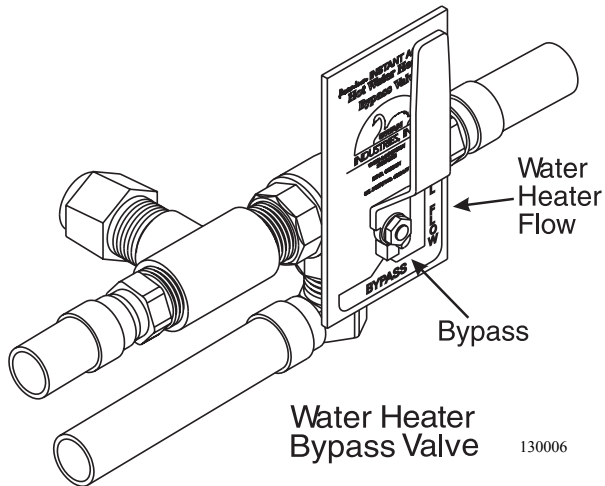

Shown in the bypass position.

The water heater bypass is a valve located on the back of the water heater. Turning the valve to **BYPASS** position diverts water away from the water heater. The water heater should be in the **BYPASS** position when winterizing. Bypassing the water heater will keep antifreeze out of the water heater, if antifreeze is used for winterization.

For normal water heater operation turn valve so that handle points to **NORMAL FLOW**.

### Tips

- Turn off water heater when not in use to conserve LP-Gas.
- The water heater tank capacity is ten gallons. When using the shower, conserve water by shutting the shower water off when not in use.
- Use caution when adapted to 30 Amp shore service, or anything less than 50 Amps. When the water heater element is in operation, it will use approximately 12 Amps. Appliances may need to be operated in sequence to avoid tripping a breaker.
- Remove the anode during the winterization procedure. If the anode has deteriorated, replace it. Water with a heavy sulfur content will coat the anode. Hot water will smell like rotten eggs. Replace the anode to eliminate the odor.
- The temperature and pressure (T & P) safety relief valve on the outside of the water heater is set to open at 210° F or 150 psi. When water temperature and pressure reach these settings the valve may drip until the pressure has dropped. Avoid opening the T & P valve manually as it may continue to leak. The valves can be purchased from most hardware stores.



**WARNING: Before beginning any service or work on the water heater make sure the LP-Gas is turned off, the 120 Volt AC source has been disconnected and the 12 Volt DC source has been disconnected. Failure to do so can result in explosion, fire or injury.**

**Draining & Storage**

If the motorhome is to be stored for a long period of time, or during the winter months, drain the water heater to prevent freeze damage.

1. Turn off the electrical power to the water heater.
2. Shut off the LP Gas supply to the water heater.
3. Open low point drains.
4. Open both Hot and Cold faucet.
5. Remove Anode Rod from the tank. Install a ¾" drain plug if RV antifreeze will be added to the system.
6. Place the Bypass lever in **BYPASS**.



**NOTE: Be sure to refill the water heater with water before resuming operation.**

- If water heater fails to light check the outside burner tube for obstructions. Spiders may make nests in the burner tube.
- If the indicator light on the monitor panel does not light, and the water heater does not light, ensure the battery cut-off switch at the entry door is on or check for a blown fuse in the house distribution panel.
- If the switch at the galley is on but there is no hot water, check the **ON/OFF** switch located outside behind the water heater inspection panel.

**Troubleshooting**

If the motorhome was not ordered with an optional washer/dryer, it may have a washer/dryer preparation package installed from the factory. The washer/dryer “prep” package includes the following items:

1. Color coded water supply lines. A red line for hot; a blue line for cold.
2. An 1½ in. waste water drain line with threaded cap, p-trap, and an automatic vent cap. This will drain the waste water into the grey water holding tank.
3. A 120 Volt receptacle located in the compartment.



**NOTE: Sidewall dryer vents are not part of the prep package. If a sidewall vent is to be installed be sure to properly seal vent to sidewall.**



**Refer to the manufacturer installation instructions if a washer/dryer is to be installed at a later date.**

**WASHER/DRYER  
PREPARED**

Further instructions are listed below which should be adhered to for safe and reliable operation:

- Do not connect the clothes dryer exhaust duct to any other duct, vent or chimney.
- Do not terminate the exhaust duct beneath the motorhome.
- Be sure to use proper length fastener when attaching exhaust vent to exterior sidewall. Stainless steel fasteners are best suited for this as they will not rust.
- If the cabinet or closet in which a washer/dryer is installed does not have vented louvered doors, the manufacturer's installation instructions may require installation of vented doors or vents to be installed in the doors. This is for sufficient circulation of drying.

## WASHER/DRYER (Optional)

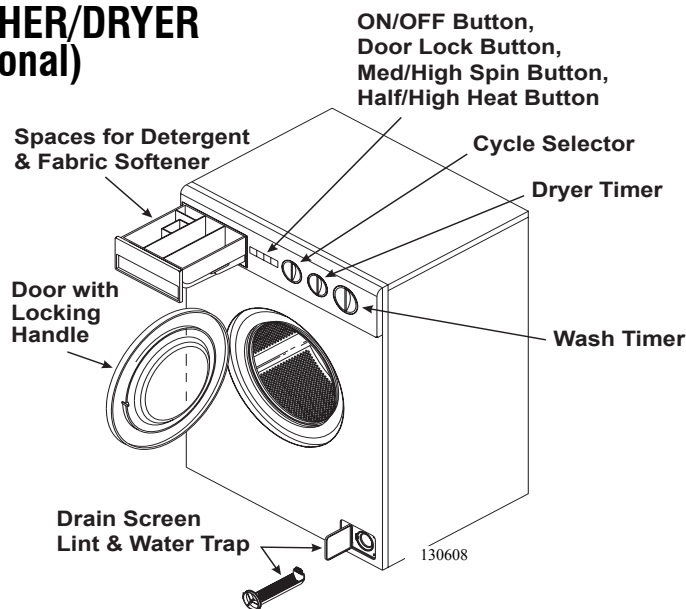

The automatic washer/dryer has a capacity of up to 10 lbs. (4.5 Kg.) of dry clothing. It is front loading with an extra large door opening for easier access. It has five wash cycles, in addition to extra rinse and spin cycles.

- The washer/dryer operates on 120 Volt AC.
- To operate the washer/dryer use shore power or the generator.
- The washer/dryer water use will be approximately 16 gallons of water.



**CAUTION: Open a window or vent while operating the dryer. It is dangerous to create negative air pressure inside the motorhome while operating fuel burning appliances.**

## Operating Instructions

Before using the washer for the first time wipe the inside and outside with a damp cloth to remove any travel dust that has accumulated. We recommend operating a rinse cycle to rinse out the washer.

**To begin a wash load:**

- Sort and pre-treat clothes (specific directions under sorting).
- Add the measured amount of detergent suggested by the package directions (maximum two tablespoons).
- Load the clothes loosely into the washer. Close the washer door.
- Turn the cycle selector knob to the desired temperature setting.
- Decide which washing cycle you wish to use. Turn the timer knob clockwise to the desired wash setting.
- Select High or Medium spin (only for regular washing).
- Press the push button ON.
- After the cycle is complete, wait two minutes for the door lock to release before attempting to open the door.



**WARNING: Do not wash or dry articles that have previously been cleaned, washed, soaked or spotted with gasoline, dry cleaning solvents or other flammable or explosive substances. They give off vapors that could ignite or explode. Do not add gasoline, dry cleaning solvents or other flammable or explosive substances to the wash water.**



**WARNING: Do not use heat to dry articles containing foam rubber or similar textured, rubber-like materials. Clean the lint screen if applicable (located on the back of the washer in the top left corner) after each use and keep the area around the exhaust opening and adjacent areas free from the accumulation of lint, dust and dirt.**

The removable drain screen, which protects the pump from lint and foreign matter, needs to be cleaned periodically. The frequency in which it is cleaned depends upon the type of clothes that are washed. Cotton articles produce more lint than nylon articles. Under no circumstance should the drain screen be removed while the machine is full of water. To clean the drain screen (on an empty machine) open the service door by pressing on the left hand side. Place a cloth or shallow tray under the drain screen housing to catch any remaining water that may drip out. It may be helpful to first set the machine to spin then remove the drain screen. This procedure reduces the amount of water released. Turn the drain screen counterclockwise and pull the drain screen out. Clean the screen to remove any dirt and lint. To replace the screen, slide it back into the housing and turn it clockwise to secure. Close the service door.



**NOTE: Check for water leaks before using the washer after removing and replacing the drain screen.**

### ***Cleaning the Drain Screen***

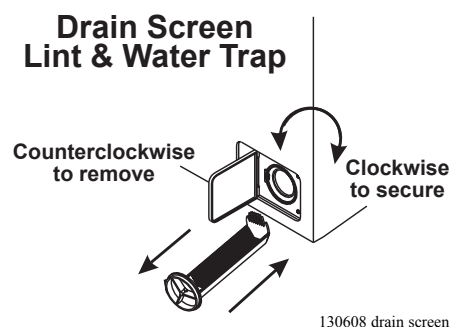

## ***Cleaning the Washer/Dryer***

Occasionally wipe the exterior cabinet of the washer/dryer with a damp cloth or sponge. Wipe dry with a soft cloth. Do not use polish on plastic trim. Clean the interior with one cup of chlorine bleach mixed with two cups of granular detergent. Run the washer through a complete cycle using the hot water. Repeat the process if necessary. Remove hard water deposits using only cleaners labeled as washer safe. Wipe the inside of the washer/dryer door with a soft cloth to remove any moisture. Periodically apply a thin coat of paste wax to the inner door, especially to the area which is immediately next to the door window. This will protect the door finish from laundry spills and discoloration.



**NOTE: Should the washer/dryer need removal for service, care should be taken as the washer/dryer weighs approximately 185 lbs. Proper accommodations should be made to avoid risk of injury.**

---

## ***Winterizing the Washer/Dryer***

**To winterize your washer/dryer follow the instructions below to avoid damage to your unit due to freezing:**

1. With the unit off, remove the wash filter to allow the water remaining (in the pump and drain hose) to be evacuated. Replace the filter.
2. Close the inlet shut-off valve located at the manabloc water system.
3. Open the low point drains to drain all the water.
4. In cold climates air should be used to blow out the system.
5. Install the water pressure regulator on a short water hose. Connect it to the water system. Use an air hose connector on the female end as this reduces pressure. Make sure one or more faucets are open.

**If antifreeze is being used in the system follow these instructions:**

1. When putting antifreeze into the water system of the motorhome, set the washer to a warm/warm fill setting and allow water to flow into the unit until the antifreeze is detected.
2. Slowly advance the timer to a rinse cycle and allow the water to flow for 10 seconds. Advance the unit to a spin cycle to remove the majority of the water from the unit.
4. With the unit off, remove the wash filter from the unit. This will allow the water remaining in the pump and drain hose to be evacuated. Replace the filter.
5. Any water remaining in the unit should contain antifreeze and be protected from freezing.



**NOTE: When placing the unit back into service, allow the unit to operate for one complete cycle before doing laundry to ensure all antifreeze has been purged from the unit.**

# SAHARA

## SECTION 5 EQUIPMENT

- INTRODUCTION • 145**
- ENTRY STEP • 145**
  - Operation • 145*
  - Tips • 146*
  - Maintenance & Lubrication • 146*
- ENTRY DOOR - Front Entry • 147**
  - Latch Adjustments • 148*
  - Screen Door - Changing the Glass • 148*
  - Screen Door - Adjusting • 148*
  - Screen Door - Removing the Screen • 149*
  - Entry Door - Side Entry • 149*
- SLIDE-OUT OPERATION • 151**
  - Extending Main Room(s) • 152*
  - Retracting Main Room(s) • 153*
  - Troubleshooting • 153*
  - Extending Bedroom Slide-out • 154*
  - Retracting Bedroom Slide-out • 155*
  - Manual Override - Bedroom Slide-out • 156*
- AWNINGS • 157**
  - Front Door • 157*
  - Awnings - Patio • 158*
  - Awning Care & Maintenance • 160*
  - Awning - Automatic Carefree (Opt.) • 161*
- SLIDE-OUT COVER • 163**
- FANS • 164**
  - Exhaust Fan • 164*
  - Tips • 164*
  - Bathroom Fan • 165*
- COCKPIT BLINDS • 165**
- DOOR - SLIDING • 166**
- SOFA BED CONVERSION • 166**
  - Sofa to Sleeper • 166*
  - Sleeper to Sofa • 166*
- DINETTE BED CONVERSION (Opt.) • 166**
- STORAGE - UNDER BED • 167**
- SUPER SLIDE (Opt.) • 167**
- ENTERTAINMENT SYSTEMS • 167**
  - Video Cassette Recorder (VCR) - (Opt.) • 167*
  - Television (Front) w/Lock-out Feature • 168*
  - Television Antenna • 168*
  - Hook-ups - TV Cable, Computer & Telephone • 171*
  - Entertainment Hook-ups - Exterior • 171*
  - Video Selector Box (Opt.) • 171*
- RADIO - DASH • 172**







---

**INTRODUCTION**

This section covers the basic operation and care of various types of equipment found in the motorhome, most of which are provided for entertainment and comfort. More detailed information about specific equipment may be found in that particular manufacturer's manual. Optional equipment will also be discussed in this section which may not apply to all motorhomes.



**Detailed information with CAUTION or WARNING instructions for the various electronics, other than what is provided in this section, can be found in the manufacturer's manual.**

---

The entry step features amber lighting under the step, automatic retraction with the ignition key in the RUN position and a last out feature. Located to the left, just inside the entry door, is the step switch.

**ENTRY STEP  
- Operation****Operating the Entry Step:**

1. With the entrance door open, turn the step switch on.
2. Close the door. The step should retract and lock in the **UP** position. The step light will remain on.
3. Open the door. The step should extend and lock in the **DOWN** position with the under step light on. The step will retract when the door is closed.
4. The step is equipped with a power switch. When the switch is turned off, the step should remain in the extended position with the door closed and the under step light off. Close the door and turn on the ignition switch. The step will retract for travel. To hold the entry step in the retracted position proceed with the following:
  - Turn the engine ignition switch off.
  - Wait 15 seconds and then turn the power step switch from off to on, then back off again. The step will stay retracted until the step switch is turned ON, or the ignition switch is turned on. The retracted position is useful for high curbs or on boat ferries.
5. With the power switch off, the step extended, the entrance door closed and the ignition turned on the ignition override system will go into effect and the step will automatically retract.
6. Turn the ignition off and open the door. The step will extend and lock in the **DOWN** position. This is the "last out" feature. When the ignition is on the step will always activate with the door movement, regardless of the power switch position.

## Tips

### If the step fails to operate:

- Verify that the step switch is **ON**.
- Check the main power supply for the step. A 20 Amp circuit breaker located on the low current plate.
- A magnetic door jam switch is used to control step operation. Use a separate magnet to apply a “trigger” to the door jam switch. Rotate test magnet to align polarity field.
- A 7 ½ Amp ATO blade fuse is used to illuminate the **STEP OUT** dash warning light. The fuse is located on the front run box.



**WARNING: If the motorhome is driven with the step in the extended position there is the possibility of causing major damage to both the step and the motorhome.**

---

## Maintenance & Lubrication

Clean all mud, salt and road grime from the step before lubricating. Lubricate all moving parts (bearings, pivot points, slides, clevis pin and the drive linkage ball) every 30 days with a good quality heat and moisture resistant penetrating grease. ***Kwik Lube Spray Grease*** is specially formulated to lubricate ***Kwik Electric Steps*** and it is also recommended for lubricating all moving parts. (Refer to the illustration.)



**NOTE: Silicone lubricants and WD-40 are not recommended as they have a tendency to evaporate and dry the mating surfaces which leaves them vulnerable to the elements.**

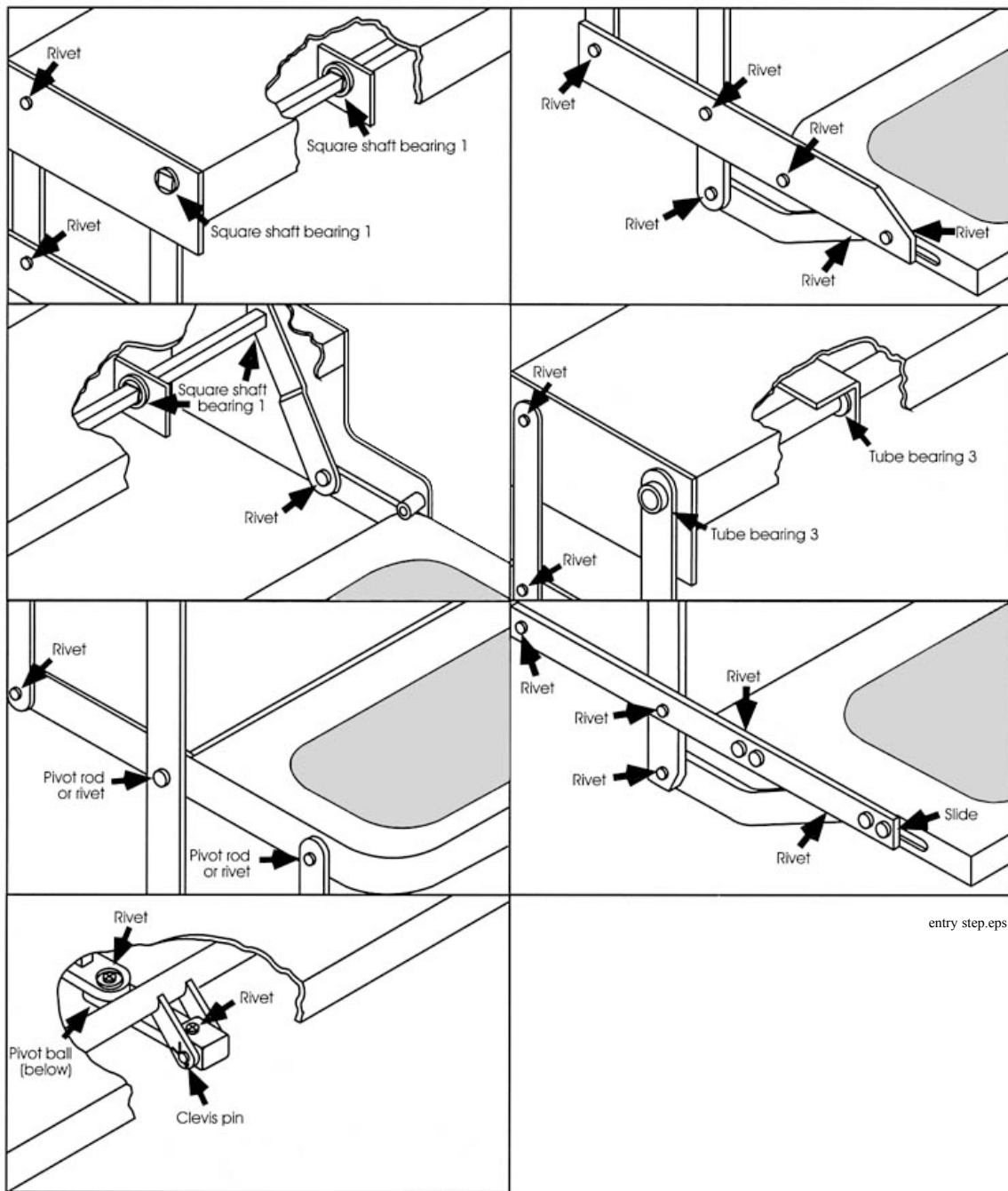

The entry door is adjusted at the factory and tested for all operations. The door incorporates three separate seals to eliminate wind noise during travel. The door uses two separate locks for safety and security. One locking system is the door handle and the other is a dead bolt. The door handle incorporates a primary and secondary latching system. This is used to ensure secure and safe latching. There are adjustments which can be made to help maintain entry door performance.

**ENTRY DOOR**  
**- Front Entry**

## **Latch Adjustments**

### **Adjusting the Entry Door Latch:**

- Determine which bolt needs adjustment.
- Slowly close the entry door observing the latch and strike bolt alignment. Do not attempt to latch if the alignment is off. If the alignment is correct, allow the latch to catch in the first (primary) position only.
- The latch should move to the second position with just slight pressure applied to the entry door. Upper and lower latches should be evenly timed. Press on the entry door to see if there is any further movement of the door.
- The entry handle should operate with little effort to open the entry door. An excessive amount of pressure indicates the bolts are set too far back.
- With a 5/8" inch box wrench or socket, loosen the movable strike bolt. Make all adjustments in small increments. Tighten the bolt firmly after making adjustments. The bolts should have slight up and down movement for vibration control in travel.
- Test the operation of the dead bolt lock to ensure proper functions.
- Silicone should be applied weekly to the entry door rubber gaskets to prevent squeaking while the motorhome is traveling. Use a one inch sponge paint brush, sprayed with silicone for easy application.



**CAUTION: When operating the entry door ensure the dead bolt latch is fully in the unlock position prior to closing the entry door. Failure to do so can result in damage to the dead bolt and/or entry door.**

---

## **Screen Door - Changing the Glass**

### **Changing the Glass in the Screen Door:**

- The screen slider is *Plexiglas*, the slider can be bowed for removal and replacement.
- Replace with new *Plexiglas* and reverse the procedure.

---

## **Screen Door - Adjusting**

### **Adjusting the Screen Door For Up and Down Location:**

- Loosen the chrome bolts on the hinge side of the screen door; four on the top and four on the bottom.
- The steel hinge has slots to allow up and down movement.
- Four Allen type screws are on the top hinge, and four on the bottom hinge, to adjust the screen door to properly fit to the entry door. The hinge should fit tightly to the trim of the door when the screen door is latched to the door and the door is open.

**Removable Screen:**

- The top half of the screen door is removable. This allows clear viewing through the entry door glass while traveling.
- To remove the top half of the screen door for travel, rotate clips and remove the screen.
- To store the screen for travel, use the clips provided on the bottom half of the screen door.

**Screen Door  
- Removing the Screen**

The entry door by design is virtually maintenance free. Installed, adjusted and tested at the factory for all operations, the door uses two separate locks for personal safety and security. The door handle incorporates a primary and secondary latching system. One locking system is the door handle and the other is a dead bolt. However, keeping the entry door in good operating condition requires some routine maintenance items on a regular basis. Adjustments can help maintain the entry door performance. These items are as follows:

- 1. Strike Plate/Bolt Adjustment:** The position of the striker plate or bolt may change over the course of time and with frequent operation of the motorhome. The setting may require adjustment to insure that the door operates smoothly and efficiently.

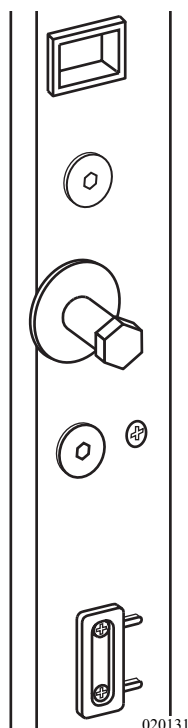
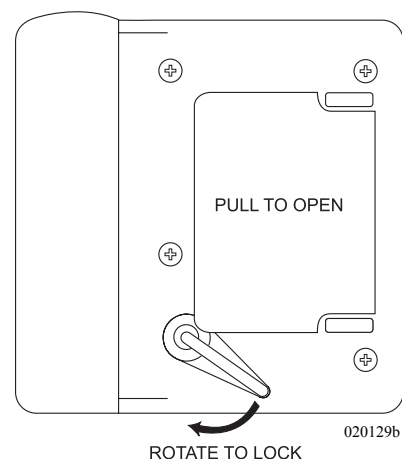
**Entry Door - Side Entry****Adjusting the Entry Door Latch:**

- Slowly close the entry door, observing the latch and strike bolt alignment. Do not attempt to close the door if the latch alignment is off. If the latch alignment is correct, close the door allowing the latch to catch in the first (primary) position only.
- The latch should move to the second position with just a slight pressure applied to the entry door. Press on the entry door to see if there is any further movement of the door.
- The entry handle should operate with little effort to open the entry door. If using an excessive amount of pressure is required, this indicates the bolt is set too far back.
- With a 5/8" box wrench or socket, loosen the strike bolt. Make all adjustments in small increments. Tighten the bolt firmly after making adjustments.
- Ensure the three torque head screws holding the latch assembly on the door are tight along with the two on the door jamb.

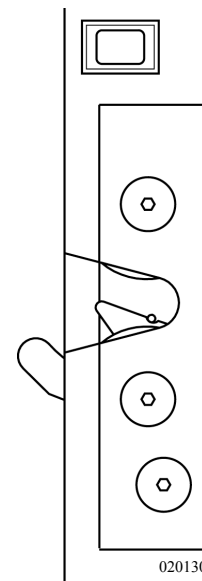

**CAUTION:** When operating the entry door ensure the dead bolt latch is fully in the unlock position prior to closing the entry door. Failure to do so can result in damage to the dead bolt and/or entry door.

**2. Locks:** The locking cylinder requires slight lubrication on an annual basis, or as needed. Use powdered graphite, not a petroleum product. Petroleum products gum the cylinder and inhibit smooth operation. The upper lock is the dead bolt, while the lower lock is the privacy lock. Applying a light coating of white lithium grease to the face of the lock bolt helps in obtaining a smooth close.

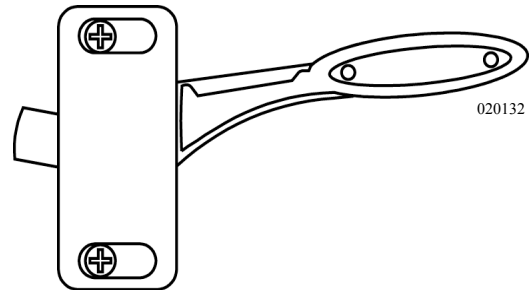

**3. Hinges:** The hinges for the door requires slight lubrication annually, or as needed, with any high-quality, dry spray lubricant.

**4. Screen Door - Adjusting:** The screen door can be adjusted to set flush in the door jam. This requires two separate adjustments be performed. The first adjustment made is at the screen door latch/catch itself. Loosen the two Phillips screws holding the latch to the door. This will permit vertical adjustment. Move the latch far enough to allow it to catch on the striker mounted on the door frame. Tighten both screws. The striker mount on the door frame permits horizontal adjustment. Again, loosen the two Phillips screws holding the striker assembly. Move the striker to center the latch and tighten the Phillips screws in place.

**5. Screen Door -Changing the Slider:** The sliding cover is a simple procedure to replace. Place the slider in the center. Pulling from the center of the slider will bow enough to allow easy removal. To re-install, reverse this procedure paying attention to install the upper left corner first and the location of the stop tabs.

**6. Fiberglass Skin:** To maintain their appearance and a long service life, the door skin panels should be washed and cleaned periodically. Cleaning will remove the accumulation of dust and dirt, which can combine with sunlight and wind to attack exposed surfaces both chemically and abrasively.

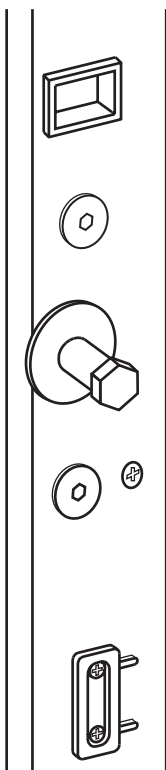

020131

**SLIDE-OUT  
OPERATION**

The main slide-out room operates by an electric switch controlling a hydraulic cylinder. Slide-out room operation uses many safety features preventing mechanical damage or physical harm. The slide-out room(s) will not operate until all safety requirements are met.

The design of the slide-out system requires very little maintenance. To ensure long life of the slide-out system, follow these simple guidelines:

- The roof of the slide-out should be checked for debris such as pine needles, dirt, leaves, sticks, etc. Any debris left on the top may cause damage to the seals when being retracted. If debris is present wash with soap and water, then rinse.
- When the room is out visually inspect the wipe seal. The seal should be clean and free of dirt or other foreign material. Inspect the seal for tears.
- In the event the slide-out room leaks, fully retract it. If necessary, tape the exterior opening closed with duct tape until repairs to the motorhome can be completed.



**NOTE: Do not use any petroleum-based products on the slide-out seal. Petroleum based products can damage the paint and will cause premature aging of the rubber seal.**



**WARNING: Move the driver's seat forward before activating the slide-out room. Damage to the upholstery can occur. The outside area must be clear of any obstructions restricting slide-out room operation. Ensure there is five or more feet of clear space outside the slide-out room prior to extending or damage can occur. When retracting the slide-out room, ensure there is sufficient clearance inside the motorhome. Never move the motorhome with any slide-out room extended.**



**CAUTION: Continuous operation of the slide-out room can drain the batteries and damage the motor from overheating.**

## Extending Main Room(s)

### To Extend the Main Slide-out Room:

- Move the driver seat forward.
- Confirm that there is at least five feet of clearance outside the motorhome for the slide-out room to extend.
- Ensure the ignition key is in the **OFF** position.
- The park brake must be applied.
- The house batteries are fully charged.
- Be sure all people, pets and objects are clear of slide-out room path.
- The control switch for the slide-out room is on the system monitor panel.
- Press and hold the front slide-out room switch in the **OUT** position. The slide-out room will slowly move to the **OUT** position. Release the switch to stop room movement. To continue the room movement, push and hold the switch in.
- Release the slide-out switch when the room is fully extended (a change in motor sound indicates extension). The slide-out drive motor will not stop automatically; the switch must be released.
- If equipped, extend additional slide-out rooms.
- Level the motorhome with the leveling system.

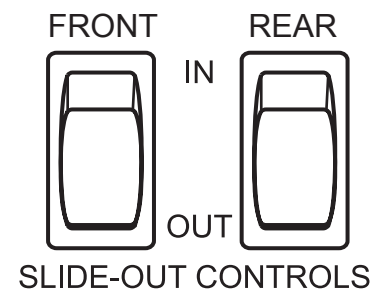

060158b



**NOTE:** Perform the slide-out room operation with the air suspension system full. Extensive damage could occur to the slide-out room and awning when extending the slide-out room in snow, sleet, ice or freezing rain. In such conditions, if the slide-out room is extended, clear the awning and ensure free movement prior to operating the slide-out room.



**CAUTION:** Dirt and grit trapped under the slide-out room could result in damage to the floor. Continuous operation of the slide-out could cause a drain on the house batteries and damage to the slide-out motor from overheating.



**Retracting Main Room(s)****To Retract the Main Slide-out Room:**

- Check for sufficient clearance inside the motorhome before retracting the slide-out room.
- Clean the floor, if applicable, to ensure there is no dirt or grit that could result in floor damage during operation.
- Move the driver's seat forward.
- Inspect the exterior to ensure there are no sags in the awning material.
- Remove any debris from the top of the slide-out room.
- Prior to retracting the slide-out room, start the motorhome. Allow the air bags to fully inflate to normal travel height.
- Retract the leveling jacks prior to operating the slide-out.
- Turn the ignition switch **OFF**. The slide-out room will not operate with the engine running.
- The house batteries should be fully charged.
- The park brake must be applied.
- Ensure all people, pets and objects are clear of the slide-out room path.
- Press and hold the switch in the **IN** position. The slide-out room will move slowly in. To stop the slide-out room, release the switch. To continue the room movement, push and hold the switch in.
- Release the switch.
- Rain water can pool on the slide-out awning. Added weight will cause the awning to sag. Upon retracting the room, the material can catch between the top of the slide room and the opening in the the motorhome. It will be necessary to retract the room in small increments, allowing the water time to run off.



**NOTE: Be sure you have sufficient clearance on the inside of the motorhome (driver's seat, etc.) before you retract the slide-out room. Ensure the floor is clean before you retract the slide-out room. Trapped dirt or grit under the slide-out room can scratch the floor surface. Never move the motorhome with the slide-out room extended.**

**If main slide room fails to operate:**

Check all related fuses. If the fuses are okay it will be necessary to call for mechanical assistance to correct the problem. The main slide room is actuated by a hydraulic cylinder. The hydraulic system operates as an enclosed loop and does not have a manual release valve.

The bedroom slide-out operates electrically. The bedroom slide-out room operates using many safety features preventing mechanical damage or physical harm. Firmly latch any cabinet doors located adjacent to the bedroom slide-out. Damage to the door or fascia can occur.

**Troubleshooting**

## Extending Bedroom Slide-out

### To Extend the Bedroom Slide-out:

- Confirm that there is at least five feet of clearance outside the motorhome for the slide-out room to extend.
- Ensure the ignition key is in the **OFF** position.
- The house batteries are fully charged.
- The house battery cut-off switch must be on.
- Locate the control switch for the slide-out, on the monitor panel.
- Ensure all people, pets and objects are clear of the slide-out room path.
- Press and hold the rear slide-out room switch in the **OUT** position. The slide-out room will slowly move to the **OUT** position. Release the switch to stop room movement. To continue the room movement, push and hold the switch in.
- Release the slide-out switch when the room is fully extended (a change in motor sound indicates extension). The slide-out drive motor will stop automatically.
- Level the motorhome with the leveling system.

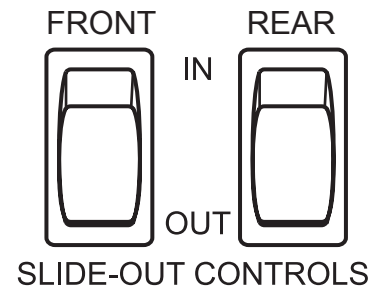

060158b



**WARNING:** Firmly latch all cabinet doors adjacent to the bedroom slide-out before extending or retracting the room. Damage to doors or fascia can occur.



**CAUTION:** Dirt and grit trapped under the slide could result in damage to the floor. Continuous operation of the slide-out could cause a drain on the house batteries and damage to the motor from overheating.



**NOTE:** Do not leave the slide-out in the extended position during severe weather. Conditions such as high winds or heavy rain may cause damage.



**NOTE:** Perform the slide-out room operation with the air suspension system full. Extensive damage could occur to the slide-out room and awning when extending the slide-out room in snow, sleet, ice or freezing rain conditions. In such conditions, if the slide-out room is extended, clear the awning and ensure free movement prior to operating the slide-out room.

**Retracting Bedroom Slide-out****To Retract the Bedroom Slide-out:**

- Check for sufficient clearance inside the motorhome before retracting the slide-out room.
- Clean the floor, if applicable, to ensure there is no dirt or grit that could result in floor damage during slide-out retraction.
- Remove any debris from the top of the slide-out room.
- Prior to retracting the slide-out room, start the motorhome. Allow the air bags to fully inflate to normal travel height.
- Retract the leveling system or prepare the air leveling system for travel prior to operating the slide-out.
- Turn the ignition switch **OFF**. The slide-out room will not operate with the engine running.
- The house batteries are fully charged.
- The house battery cut-off switch must be on.
- Locate the control switch for the slide-out, usually located on the monitor panel.
- Clear all people, pets and objects from the slide-out room path.
- Press and hold the switch in the **IN** position. The slide-out room will move slowly in. To stop the slide-out room before the room reaches the **IN** position, release the switch. To continue the room movement, push and hold the switch in. The motor will automatically stop when the slide-out room is fully retracted.
- Release the switch.
- Rain water can pool on the slide-out awning. Added weight will cause the awning to sag. Upon retracting the room, the material can catch between the top of the slide room and the opening in the the motorhome. It will be necessary to retract the room in small increments, allowing the water time to run off.



**CAUTION: Continuous operation of the slide-out room can drain the battery and damage the slide-out motor from overheating. Never move the motorhome without having the slide-out room retracted.**

If the slide-out room does not respond from the switch, check that all the safety features are in place. The bedroom slide-out system can be retracted in the event of a power loss.

**If the room does not move when the switch is pressed:**

- Check to make sure the battery cut-off switch is on.
- Check if the battery is fully charged and connected.



**WARNING: Do not work on the slide-out system unless the battery is disconnected. Make sure the floor is clean before retracting the slide-out room. Dirt or grit that is trapped under the slide-out can cause damage to the floor.**

## Manual Override - Bedroom Slide-out

After the previous items have been checked, and the room still does not move when the slide-out switch is pressed, follow these simple steps to manually override the slide-out room.



Slide Motor. Loosen the two wing nuts to separate the electric brake from the motor.

Slide brake.tif

### Manual Override for Bedroom Slide-out:

1. Disconnect the battery cables from the battery.
2. Lift up the mattress and baseboard to gain access to the slide-out mechanism.
3. Locate the slide motor. Loosen the two wing nuts retaining the electric brake to the shaft of the motor. Separate brake from slide motor.
4. Using a suitable wrench, rotate the large nut located on the intermediate shaft. Rotate shaft until room is fully seated in closed position.
5. Engage brake with slide motor by aligning slot in brake with indexing shaft of motor. Slight rotation of intermediate shaft may be necessary for alignment.
6. Secure brake to motor by tightening wing nuts.

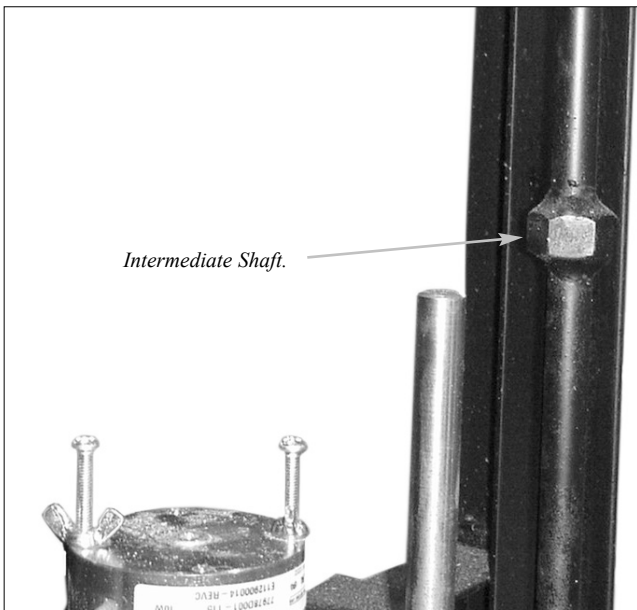

Intermediate Shaft.tif

## AWNINGS - Front Door

### To Extend the Awning:

- Hook the pull strap loop with awning pull rod.
- Pull strap until awning is at full extension.  
With free hand, lever out inner arms.
- Mate the slot of inner arm with hook on side of the motorhome. Repeat procedure for other arm.
- Release strap slowly ensuring inner arms are secure. Slide the strap to rear of awning roll tube and tie to rear arm.
- Loosen locking knobs for both arms and extend arms so the canvas will clear door in the open position.

### To Retract the Awning:

- Loosen locking knobs for both arms. Lower arms to stop bolts. Tighten knobs.
- Untie the pull strap and slide strap to center of awning roll tube.
- Pull down on pull strap with a firm grip until tension is off the inner arms. Fold inner arms and attach them to the velcro.
- Carefully allow material to wind onto awning roll tube while holding strap in a neutral position. This will allow material to roll up evenly.
- Awning end caps should be against the rubber bumpers. If one end cap is off, pull down on awning pull strap while holding strap slightly to opposite side, allowing awning to roll back up into position.

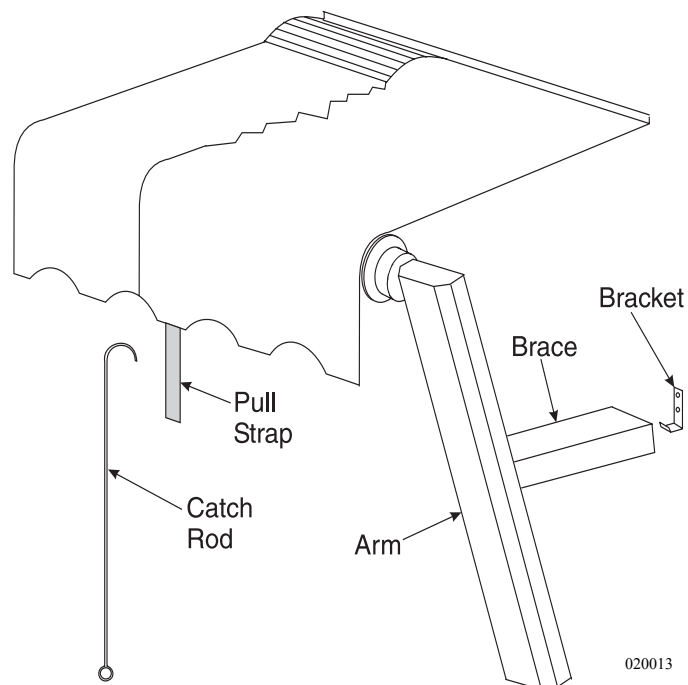

020013



**CAUTION:** When the awning is at full extension do not allow the awning to snap back into the retracted position. Personal injury or damage to the awning or motorhome may occur.

**Awning - Patio**

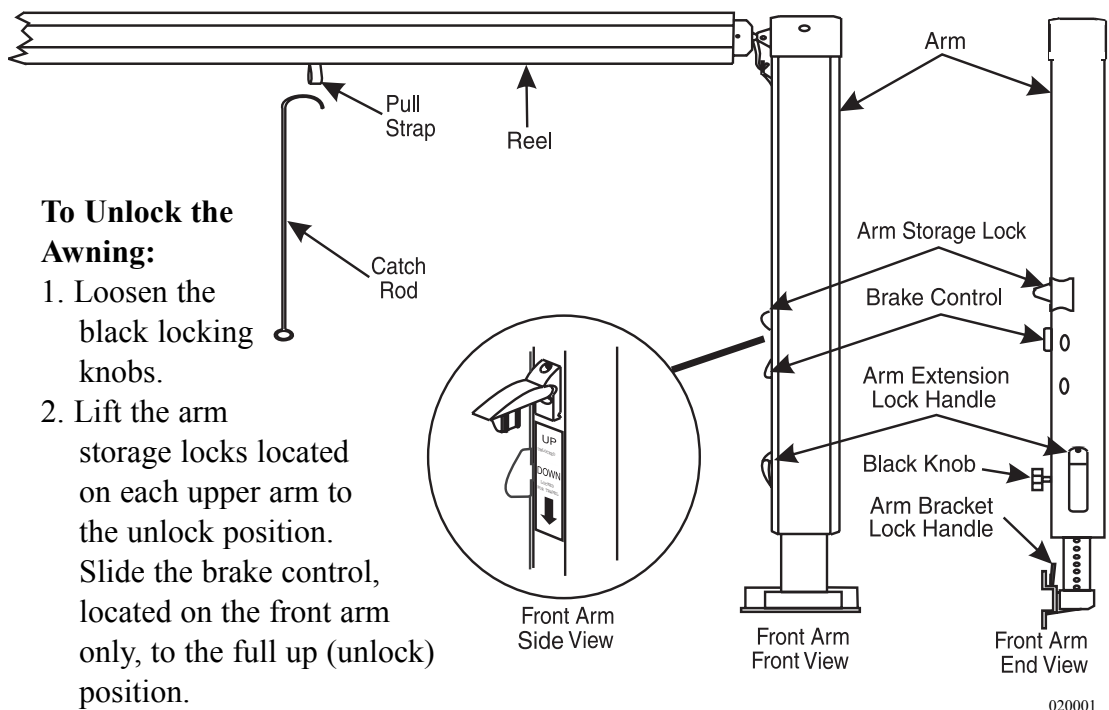

**To Unlock the Awning:**

1. Loosen the black locking knobs.
2. Lift the arm storage locks located on each upper arm to the unlock position. Slide the brake control, located on the front arm only, to the full up (unlock) position.

**To Extend the Patio Awning:**

1. Hook the loop of the center pull strap with the pull wand and draw the awning away from the motorhome to the desired extension. Slide the center pull strap to one end of the awning and store it.
2. Slide the inner rafters to the top of each arm and push outward to the tension canopy. Tighten the black locking knobs.
3. Raise the arm extension lock handles and slide the awning upward. Lower the lock handles and move the awning arm upward or downward to lock the detent into the hole. First, raise the lock handles on the main side. Next, raise the lock handles to the entry door. Go to the other awning arm and do the same. Make sure the awning is straight.

**To Retract the Patio Awning:**

Retract the arms and lower the awning until the arms rest on the lower stop bolts and lock into position. Loosen the two black locking knobs. Release the locking tab on the end of the awning leg. Slide the pull strap to the center of the awning while holding on to the strap. Allow the awning to roll up to the stored position.

- Snap the arm storage locks into the down position and tighten the black locking knobs.
- Verify that the brake control is in the locked or closed position.

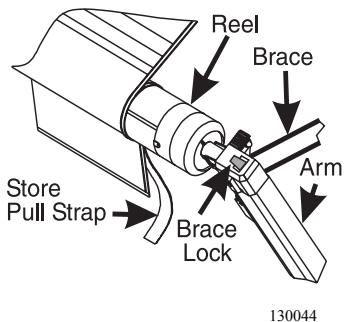

**Rain Release Setting:**

After the awning has been extended, choose the rain release position to prevent water build up on the awning. To position the awning in the rain release setting, lower one arm of the awning and leave the other arm in the normal position. This will create enough of a slope for adequate water run off.

Rain Release Setting

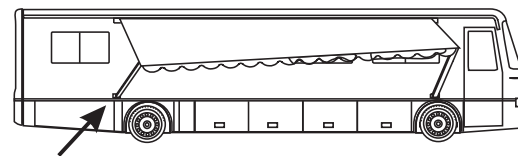

One arm should be set lower than the other for proper water run-off.

020031

**Using the Carport Feature:**

**(Not available with Carefree One Touch Awning.)**

1. Extend the braces and lock them into the end of the side arms. Tighten the black knobs.
2. Extend the awning as described under “To Extend Awning.”
3. Unlatch the bottom of the rear arm by pushing in on the lock handle on the arm bracket. Swing the arm away from the motorhome to an upright position.
4. Raise the rear arm extension lock handle all the way up to the unlocked position. Extend the arm to position the awning at the desired height and lower the lock handle to lock the arms in place.
5. Drive the stakes through the bottom holes in the arm.
6. Repeat instructions 1 through 5 for the front arm extension lock handle.

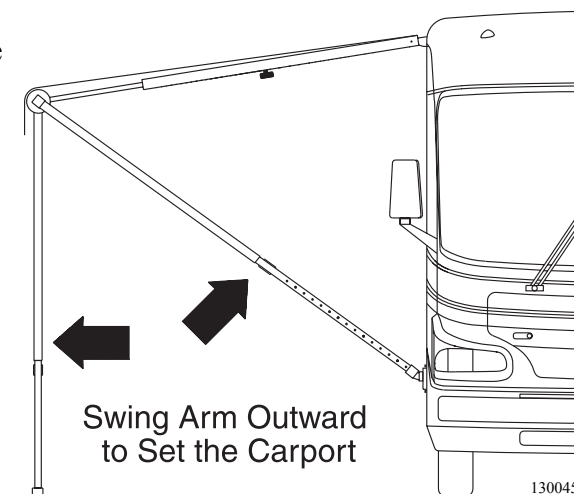

130045



**NOTE: To move the awning out of the carport position reverse the above steps.**

**Securing the Awning for Travel:**

Before traveling, check the following:

1. The awning is fully retracted against the sides of the motorhome.
2. The black locking knobs are tightened.
3. The storage locks are down and in the locked position.
4. The brake control is in the full down (locked) position, and no red warning is showing.
5. The bottom of the front and rear arms are latched properly into the bottom brackets.
6. The catch rod is stored away.

## **Awning Care & Maintenance**

Mildew will not form on the awning material itself, but it may form on the dust accumulated on the canopy. A quality vinyl cleaner, such as Carefree Awning Magic, will help keep your awning looking new. Be sure to follow the instructions on the container.



**NOTE: Allow the awning material to thoroughly dry before rolling the awning up. Metal surfaces should be cleaned with soapy water and thoroughly rinsed.**

### **Care of Awning Acrylic Fabric:**

The acrylic fabric should be cleaned regularly before substances such as dirt, leaves, etc., are allowed to accumulate on, and become embedded in, the fabric. The fabric can be cleaned without being removed from the awning. Simply brush off any loose dirt, leaves, etc. Hose down and clean with a cloth and mild soap. **Do not use detergents.** Allow to air dry, preferably on a warm sunny day. Should you have to retract the awning when the fabric is wet, it should be extended at the first opportunity to finish air drying.

Avoid leaving the awning partially extended during rainy conditions. The awning is at the strongest setting when the awning is fully extended.

### **Cleaning and Maintenance:**

- **Washing:** On a monthly basis, loosen hardened dirt and remove dust from the awning with a dry, medium bristle brush. Thoroughly rinse both the top and bottom with a hose. This process can be made easier with awning maintenance products. Saturate the fabric with the solution and leave it on for 15-20 minutes. Wash both sides of the awning using an awning brush. If necessary, reapply the solution to keep fabric saturated. Rinse the awning thoroughly. Repeat, if necessary, until most of the stains disappear.
- **Water Leaks:** If leaking occurs after washing, it generally results from insufficient rinsing. If water drips through the needle holes in the stitching use a commercial seam sealer which is available in canvas and trailer supply stores. Paraffin wax may also be applied to the top of the seams. As the awning “weathers” these holes will normally seal themselves.

It is normal for slight leakage to occur through the fabric where water is allowed to accumulate or pocket on the fabric. See “Storm Precautions” for information on the awning settings for proper water drainage. Sometimes soap or chemical residue, such as from active agents in insect fog or sprays, can “wet” the fabric so that it appears unable to repel water. Rinse the fabric thoroughly and test to see if it is water repellent after it dries. If leakage continues after repeating the washing and thoroughly rinsing, please contact Carefree Awning Magic concerning further maintenance.



- **Storm Precautions:** The warranty does not cover damage caused by acts of nature; therefore, steps should be taken to prevent damage from occurring due to wind, rain or storms. If you are leaving or retiring for the night, close the awning. This takes only a few seconds and it gives the best protection for the awning. If unable to close the awning, lower both ends of it as far as you can. This will create a sufficient slope for water run-off. One end may be lowered to sufficiently divert the water, if the awning is being monitored.

Water weighs 8.33 pounds per gallon. The awning was not made to withstand the 500 to 700 pounds that could accumulate. It is best not to subject the awning and the motorhome to the needless strain.

The Carefree One Touch automatic awning requires only “finger tip” operation. A key lock on the One Touch switch pad is provided to prevent accidental deployment of the awning while the motorhome is in motion. The key is removable in the lock or unlock position. Gas filled struts keep the awning fabric tight at any extended position. The 12 Volt DC motor for the One Touch awning uses approximately 15 Amps while in operation.

#### To Extend the Awning:

- Verify all persons and objects are clear from the extend path of the awning and related hardware.
- Turn the One Touch key to the **ON** position.
- Depress and hold the momentary switch to **EXTEND**. Motor will automatically stop at full extension.
- Allow 14 seconds for awning to reach full extension.
- Extension distance or fabric tension is adjusted by toggling between **RETRACT** and **EXTEND**.
- Turn the One Touch key to the **OFF** position.
- Install the wind braces (2) between the upper rafter and the main arm. Adjust wind brace so the inner spring is under tension.



**CAUTION:** The patio awning requires nine feet of lateral clearance from the side of the motorhome. This distance will allow the awning to reach full extension. The One Touch patio awning was not designed with a carport feature or a rain release setting. The awning should be retracted if the motorhome is left unattended or high wind conditions exist. Otherwise, wind damage to the awning may occur.



**NOTE:** It is not required to have the awning at full extension. Awning may be stopped at any time of extension or retraction by releasing the momentary switch.

#### Awning - Automatic Carefree (Optional)



030821

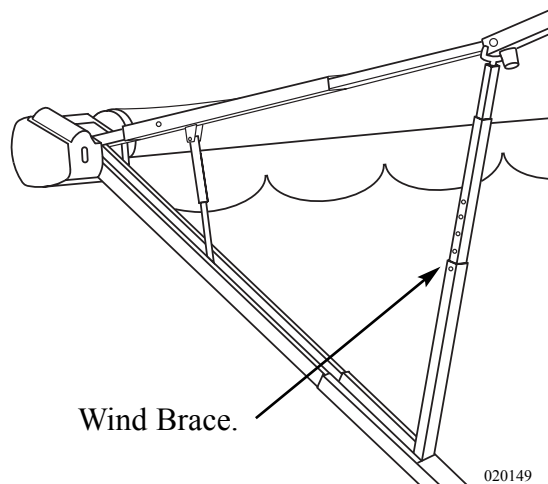

020149

**To Retract the Awning:**

- Remove the wind braces.
- Verify all persons and objects are clear from the retract path of the awning and related hardware.
- Turn the One Touch key to the **ON** position.
- Press and hold the momentary switch to **RETRACT**. The motor will automatically stop at full retraction.
- It takes approximately 14 seconds for the awning to travel from the fully extended position to the fully retracted position.
- Turn the One Touch key to the **OFF** position to avoid accidental deployment of the awning while the vehicle is in motion.

**Tips - If the awning fails to retract or extend:**

- Verify the One Touch key is in the **ON** position.
- The house battery cut off switch is in the **ON** position.
- The house battery voltage is at 12 Volts or above.
- Verify proper electrical connection from the awning motor to the side of the motorhome.

**Emergency Retract Procedure:**

If the One Touch awning fails to retract and proper DC voltages have been verified, the One Touch awning has two emergency methods of alternately retracting the awning.

1. Two exposed electrical studs are mounted externally at the forward end of the awning at the motor assembly. An alternate 12 Volt DC positive and negative supply may be applied to these connections. If awning fails to move, reverse the polarity of the alternate supply leads.
2. On the motor assembly, mounted externally at the forward end of the awning, is an opening. Insert a 9/64" Allen hex wrench. Using an electric drill, wind the awning to the retract position.

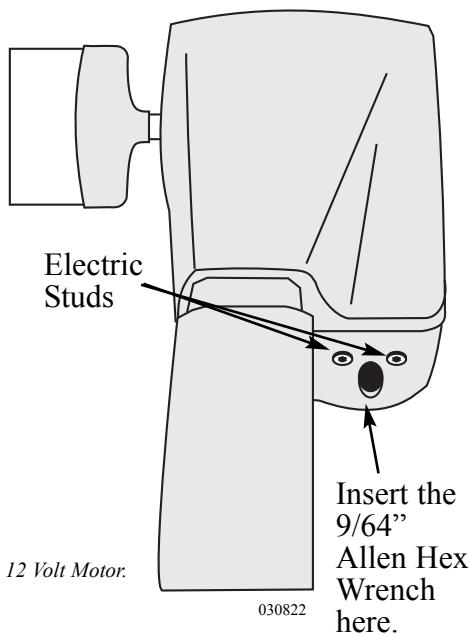

**CAUTION: When using an alternate method to operate the awning, use extreme care to keep appendages, hair or loose clothing away from exposed rotating hardware.**

**SLIDE-OUT COVER**

The slide-out cover is automatic. When the slide-out moves in or out, the cover reacts to the slide-out direction. A fixed edge of the slide-out cover is installed into an awning rail, mounted just above the slide-out. A spring-loaded roller with special brackets mounts to the slide-out. In a hard rain, the cover helps prevent water from penetrating the seal of the slide-out.

The slide-out cover will extend automatically attaining full coverage when the slide-out achieves maximum extension.



**NOTE: Water may pool on top of the extended cover. As the slide-out is retracted, the water is removed when the cover retracts.**

The slide-out cover retracts automatically and rolls up to the travel position when the slide-out is completely closed.



**NOTE: When retracting the slide-out, stop the room approximately halfway. Confirm that the fabric is rolling properly before fully retracting the slide-out.**

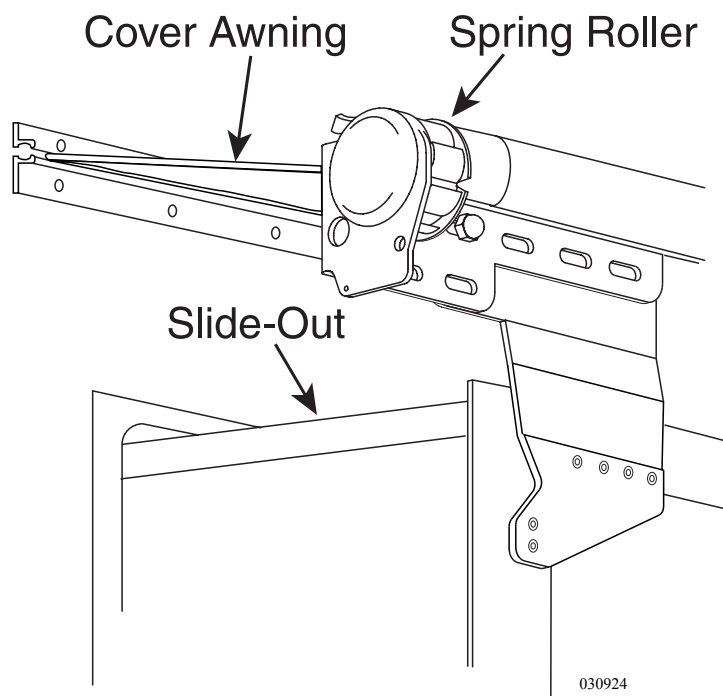

## FANS Exhaust Fan

The exhaust fan is a three-speed fan with a “0” or **OFF** position on the fan. The exhaust fan requires the presence of 12 Volt DC to operate. The fan will either pull in air or extract air from the motorhome depending on how the **IN/OUT** switch was set. The **IN/OUT** switch controls the direction of the fan rotation. There are three basic controls located on the ceiling vent fan. The knurled knob manually opens and closes the dome cover. The rotary knob selects the operating speed of the fan. When the dome cover opens approximately two inches, the fan motor begins to operate. During normal operations the knurled knob offers manual control of the dome cover for opening and closing.

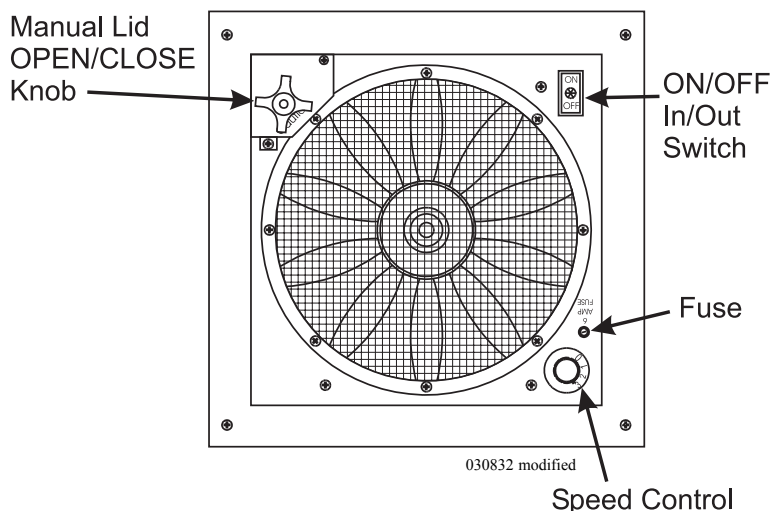

### To Operate the Fan:

- The Battery cut-off switch needs to be set **ON**.
- The dome manually opens and closes using the knurled knob.
- Select the desired fan direction to **IN/OUT**.
- Select the desired fan speed on the Speed Control dial:
  - Zero = OFF.**
  - One = LOW.**
  - Two = MEDIUM.**
  - Three = HIGH.**



**NOTE: Let fan come to a complete stop before changing fan direction.**



**NOTE: If the speed switch is in the "0" position the fan operates only as a vent.**

### Tips

- To keep condensation from accumulating open the vent fan lids slightly to help the air circulate. Condensation occurs naturally from fluctuations in interior and exterior temperatures, humidity and dew point changes, steam from cooking, or boiling large amounts of water on the cooktop. Shower usage also produces condensation.
- If the fan fails to operate, check for either a blown fuse in the domestic fuse panel or the 6-amp fuse on the fan.
- To clean the screen, remove the eight screws holding it in place. Wash the screen using a non-abrasive soap and water. Re-install the screen and tighten the screws.

- Keep all the vents closed when using the Fantastic Fan Vent. Direct the airflow by slightly opening the window(s) on the shaded side of the motorhome to obtain the maximum airflow, especially on hot, sunny days. Close all the roof vents. The area between the open window(s) and the Fantastic Vent supplies the maximum airflow and providing the most comfort.



**NOTE: Do not leave the vent cover open while the motorhome is stored or unattended for extended periods. High winds, other unusual conditions or obstructions may prevent closing. The resulting leakage could cause serious damage.**

The motorhome is equipped with roof air vents which are manually operated. The vent is opened or closed by simply turning the crank handle in the desired direction. The fan, which is for ventilation only as it will not help cool the motorhome, can be operated by pushing the small power button. The vent must be opened before using the power fan. To close the power air vent, push in the power button to stop the fan and close the vent.

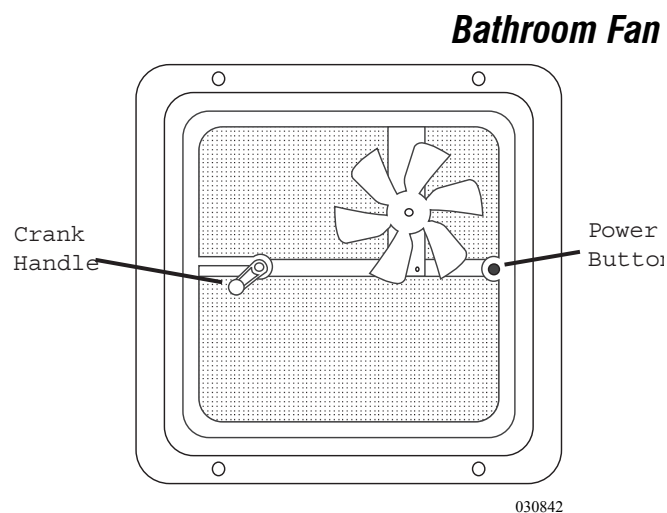

The cockpit blinds are 12 Volt DC operating from the house batteries. One blind assembly is used for each window located in the cockpit area.

## COCKPIT BLINDS

### To Operate the Blind:

- The house battery cut-off switch must be on.
- Push the switch down to lower the desired blind.
- Push the switch up to raise any blind.



**NOTE: Do not attempt to move or drive the motorhome with any blind in the lowered position.**

## DOOR - SLIDING

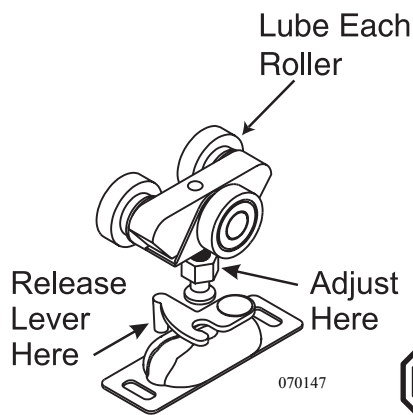

The sliding pocket door uses two rollers at the top of each door. During the life of the motorhome the sliding door may need adjusting. The sliding pocket door can be adjusted to close tight against the wall. Locate the small wrench and turn the adjusting screw upward or downward.

If, for any reason, the pocket door needs to be removed, locate the portion that is secured to the top of the pocket door and rotate the small lever outward to release the latches.



**The pocket door rollers should be lubed with just a small drop of oil once a year to help increase the life of the rollers and improve the sliding of the door.**

## SOFA BED CONVERSION

The sofa will convert easily into a bed. The sofa comes equipped with safety belts and these should be used if occupied during travel.

### *Sofa to Sleeper*

- Raise the sofa seat base until seat base and backrest form a “V” shape by lifting up from the center of sofa just below the seat cushions.
- Push down on seat base until the seat base and backrest are flat.
- Fold seat belts out of the way.

### *Sleeper to Sofa*

- Lift the seat base up until seat and back rest are in a “V” shape.
- Push down on seat base.

## DINETTE BED CONVERSION (Optional)

- The booth dinette easily converts into a bed.
- Lift or remove the seat cushions to permit the table to swing down into position.
- With a firm grip, lift front edge of the table approximately six inches and push table leg lock to release the support leg.
- Swing the table leg up locking the leg into the horizontal position.
- Continue lifting table until table stays are clear of retainers. Pull outward and lower table down.
- Use both seat cushions and one back cushion for a mattress. Leave one back cushion in a vertical position.



**WARNING: Do not occupy the booth dinette, if not equipped with safety belts or the dining chairs while the motorhome is in motion. To avoid personal injury to occupants in case of a crash or sudden stop, chairs must be stored in an enclosed area or secured with tie down straps while the motorhome is in motion.**

---

To use the storage compartment located under the bed, locate and unlock the bed deck latches. Lift up the bed by the front edge of the mattress platform. Gas struts hold the mattress and platform open.

## **STORAGE - UNDER BED**



**NOTE: Do not over stress gas struts by rapidly opening or closing the bed access cover, as this action can damage the struts or mounts. In extreme cold gas struts may not hold the mattress platform in the open position.**

---

The super slide is an option that is available for use in the storage compartment bays of the motorhome. This allows for the pay-load to slide outward for easier access.

## **SUPER SLIDE (Optional)**

- The motorhome must be level before opening.
- There are two latch releases: lift and hold up to release one, pull outward while pulling on the slide to release the other.
- Maximum weight capacity is 1,000 lbs. Never exceed this amount.



**WARNING: The motorhome must be level when sliding the drawer out of the bay compartment. The drawer can slide out abruptly, if the motorhome is not level, and cause bodily harm.**

---

The components used to make up the entertainment center are carefully selected to provide the highest quality in audio and visual enjoyment. There are several pieces of equipment, which encompass the entertainment center. The following paragraphs will discuss the operations and various components. Use the instructions given in the Video Selector Box section to use these components.

## **ENTERTAINMENT SYSTEMS**

---

The videocassette recorder is the same one found in most homes. The VHS Compatibility allows recording and playing back programs on standard VHS tapes. The Audio/Video Input Jacks in the front allows for quick, easy connections of additional video equipment. Easy Setup procedures provide the flexibility to quickly adapt the configuration for RV usage.

## **Video Cassette Recorder (VCR) - (Optional)**

**Television (Front)  
w/Lock-out Feature**

The remote control color television located above the pilot seat has lock-out circuitry. Simply stated, the ignition switch controls the front TV power outlet. Only with the ignition OFF will the front TV operate. No other television set will be affected by the lock-out circuitry. The TV operates on 120 Volt AC power only. This power can be provided by shore power, the generator or the inverter. Viewing time of the front TV from the inverter depends on the state of charge of the house batteries and any additional 12 Volt DC circuitry which is being operated.

---

**Television Antenna**

The television antenna is a manual crank up style antenna with built in electronics that use 12 Volts DC to "boost" signal strength. Signals that are weak or fuzzy can be amplified by turning on the boost switch in the passenger front overhead cabinet. The antenna and booster work together to provide the best possible picture for most situations. Certain conditions occur when no amplification is needed, and in fact may make the picture worse. The television station will send a signal that resembles the waves or rings of water from a rock thrown into a still pond. The radiating television signal can hit an object such as a mountain and come back. The result one sees in the television picture is a double image. The antenna will receive a signal from the initial pass, then receive an additional signal from the rebound resulting in a split or double image. In this case, the picture may be improved by no amplification or even lowering the antenna.



**NOTE: Do not move the motorhome with antenna in the raised position, it can be damaged by tree limbs or wires.**



**WARNING: Before raising antenna make an outside, visual inspection for any obstructions or overhead electrical wires. Damage to the antenna, severe shock, personal injury or death can occur from inadequate clearance.**



**To Raise the Antenna:**

- Rotate the crank handle clockwise to raise the antenna (it is approximately 14 ½ turns).
- Pull down on the outside directional wheel and rotate the antenna until the best picture is obtained. The directional wheel is spring loaded.



**WARNING: Do not raise a TV antenna near overhead electrical wires as contact may cause serious injury or death. The motorhome must not be driven with the antenna in a raised or partially raised position. Worm gear or worm breakage may result.**

**To Lower The Antenna:**

- Pull down on the directional wheel and align arrows together.
- Rotate the crank handle counterclockwise to lower the antenna fully into the cradle. Make an outside visual inspection to ensure the antenna is properly stowed.

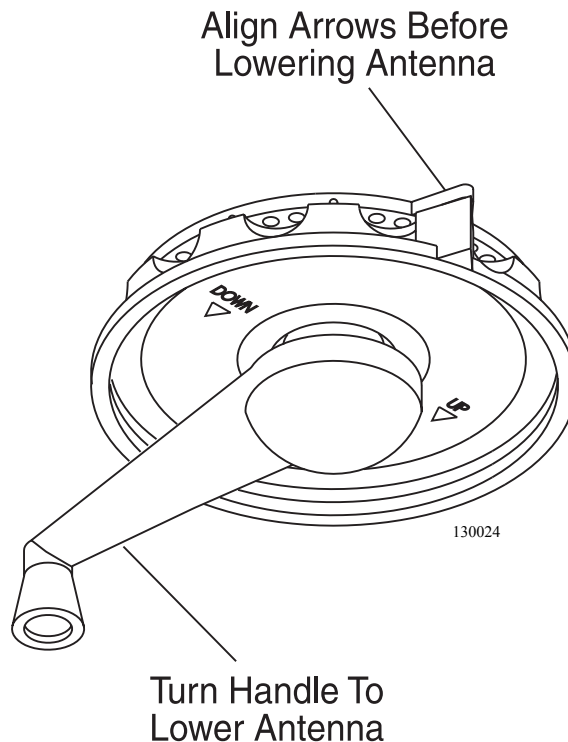
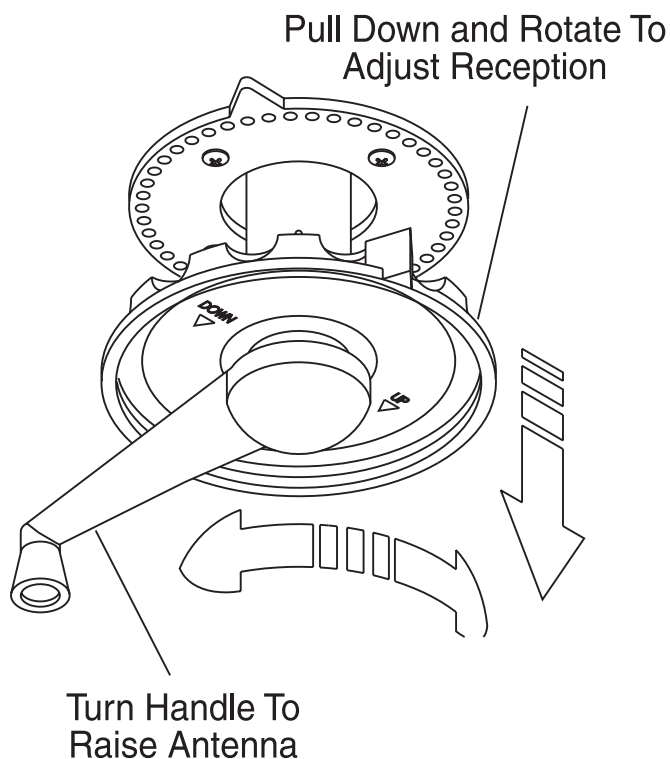

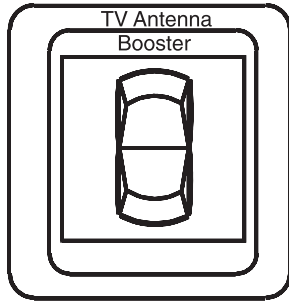

030261

**Boost Operation:**

To boost the antenna signal to the TV or VCR, use the boost switch. Turn this switch to the **ON** position. Turn the boost switch off when not in use. The switch is located on the left side of the VCR.

**Troubleshooting TV Reception with Amplifier Installed:**

- Check the domestic battery for correct voltage. The antenna booster receives power from the domestic fuse block inside the coach.
- Check the fuse from the grey wire.
- If there is no picture or the picture is weak, be sure the antenna is working. If it is working and the picture is weak, an amplifier may not improve the signal.
- Check for 12 Volt DC and correct polarity on the input lines. Make sure the coax fitting and center wire are making contact at the antenna and the amplifier.

**Troubleshooting the Coax Wire:**

Weak or no picture can indicate a possible shorted or open coax. The coax cable is made of two conductors. A center conductor which is usually copper and the ground which is woven or braided aluminum. The "die-electric" insulating material separates the two conductors. The ground and center conductors are to remain electrically separate from one another. When installing a metal end onto a coax cable, use care so none of the woven ground strands comes in contact with the center conductor. A continuity tester is required to test a suspected fault in a coax wire. Unscrew both ends of the suspected bad coax run, with the continuity tester check between the center conductor and the outside threaded ring. If continuity is present, the coax is shorted. To test for an open connection of a particular coax run use one test lead and touch the threaded end of the coax. With the other test lead, touch the threaded ring at the opposite end. Continuity should be present. Perform the same test procedure on the center conductor. Proper electrical coax operation should indicate continuity from the center conductor at one end to center conductor at other end. Continuity should be present between each coax terminal end. There should be no continuity between the terminal end and center conductor. Though damage does not usually occur from a shorted or open coax cable, picture quality is compromised.

The motorhome is equipped with cable TV and telephone hook-ups, located in the electrical service center. For convenience, there are auxiliary outlets located at the co-pilot seat and on the optional computer desk. This connection is set up for a telephone or laptop computer.

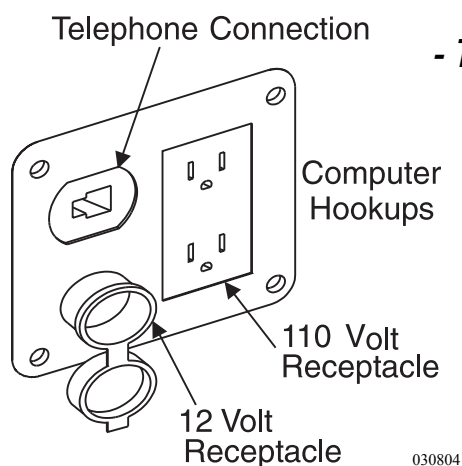

**Hook-ups  
- TV Cable, Computer  
& Telephone**

030804

Provided for convenience in the passenger bay are entertainment connections. These include telephone jack, cable TV hook-up, a 12 Volt DC utility outlet and 120 Volt AC electrical outlet. A detachable reel light with magnetic base with an 18' foot cord offers additional lighting when needed.

**Entertainment  
Hook-up - Exterior**

**Reel Light - Operation:**

1. Lift the lever and pull the light out.
2. The light has a magnetic base attached. Locate a place to attach the light so you can work hands free.
3. To replace bulb push down on clear plastic cover and twist counterclockwise.
4. To rewind, crank the handle in the retract direction. When fully retracted, push down on the lever handle to keep the light locked into position.

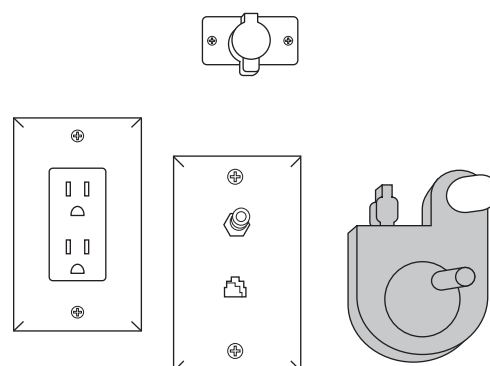

060192

The motorhome is equipped with a video selector box located in the overhead cabinet. The selector box receives audio/video signals from three different sources: the roof mounted antenna (ANT), shore cable (AUX) or the VCR. The video selector box directs the signals to either the front or the bedroom TV, and directs the signal from shore cable (AUX) or the roof-mounted antenna (ANT) to the VCR. The selector box switches are divided into three groups: TV1 (front TV), TV2 (rear TV) and the VCR. Both the TV1 and TV2 button groups perform the same functions. For example: To watch the front TV (TV1) from the antenna, press the ANT button in the TV1 group. This will direct the signal from the antenna to the front TV.

**Video Selector Box  
(Optional)**



**NOTE: The audio/video signals for the cable hook-up in the storage compartment are received through the TV 2 group.**

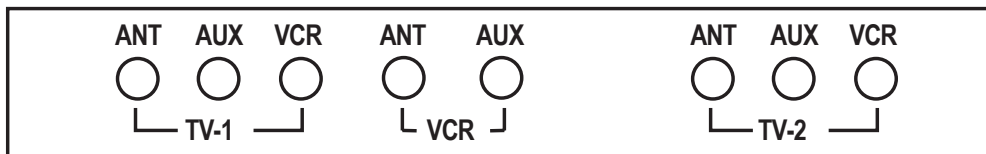

030836

**To Watch the Front TV:**

- Using the antenna, press the **ANT** button in the **TV1** group.
- Using the shore cable, press the **AUX** button in the **TV1** group.
- Using the VCR, turn the TV to **channel 3** and press the **VCR** button in the **TV1** group.
- Using the DVD player, press the **WHO/INPUT** button on the TV remote until **VID** displays.



**NOTE: The TV may be programmed to select VID through normal channel tuning. It will be located between the highest and lowest channel programmed. See the owners manual for the TV for detailed programming instructions.**

**To Watch the Rear TV:**

- Using the antenna, press the **ANT** button in the **TV2** group.
- Using the shore cable, press the **AUX** button in the **TV2** group.
- Using the VCR, turn the TV to **channel 3** and press the **VCR** button in the **TV2** group.



**NOTE: When watching TV and using the VCR (such as playing a tape) make sure the TV is tuned to channel 3.**

**Using the VCR:**

- With the antenna, press the **ANT** button in the **VCR** group.
- With the shore cable, press the **AUX** button in the **VCR** group.

**RADIO - DASH**

The dash radio is a tuner and a compact disc player. It holds up to eighteen preset FM stations and six AM stations. Other features are an attenuate mode; loudness control, clock display and auto seek tuning. The compact disc player features are fast forward and reverse, random track play, repeat and pause.

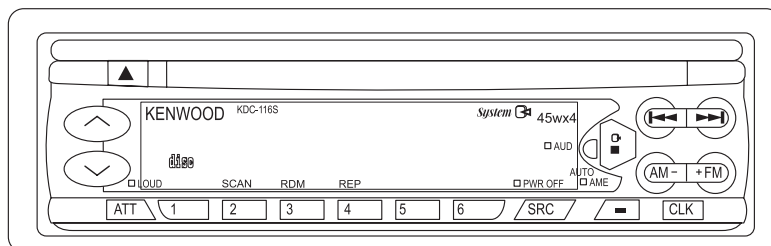

030190

**Operation:**

- Turn **ON** the house battery cut-off switch, located at entry door.
- Press the **SRC** button to turn on the radio.
- Press and hold the **SRC** button to turn off the radio.

**Function of Features:**

- **Volume** - Use the Volume Control arrows to increase or decrease volume.
- Press the **CLK** button for clock display.
- **Clock Set/Adjust** - Press and hold the **CLK** button for three seconds. The clock display will flash. Pressing either the **AM/FM** button selects the desired hour. The **LEFT** and **RIGHT** arrow buttons selects the desired minutes. Pressing the **CLK** button again sets the clock.
- Insert a compact disc. Press the **SRC** button to toggle between tuner and disc.
- Press the **ATT** button to attenuate the sound. Press and hold the **SRC** button for "loud" bass control.

**Tips:**

1. If the radio does not function, check the house battery cut-off switch to make sure it is on.
2. The LCD display may become difficult to read at temperatures at or below 41° F.

For detailed information and operating instructions on the stereo and CD player system, refer to the manufacturer's manual. Additional and detailed information for the dash radio functions and operations can be found in the Owner's Information File Box.

**NOTES**

# SAHARA

## SECTION 6 WATER SYSTEMS

WATER SYSTEMS - INTRODUCTION	• 177
MONITOR PANEL - <i>Measurement &amp; Calibration</i>	• 177
WATER TANK - FRESH FILL	• 178
WATER - CITY HOOK-UP	• 178
WATER PUMP	• 179
<i>Water Pump - Troubleshooting</i>	• 180
WATER SYSTEM - <i>Troubleshooting</i>	• 181
WATER SYSTEM - <i>Disinfecting Fresh Water</i>	• 181
WASTE WATER SYSTEMS	• 182
<i>Proper Waste Disposal</i>	• 182
<i>What Not to Put in Waste Holding Tanks</i>	• 183
<i>Waste Drains &amp; Sewage Tanks</i>	• 183
<i>Waste Drain Hose</i>	• 184
<i>What to Put into the Holding Tanks - Black Water Tank</i>	• 185
<i>What to Put into the Holding Tanks - Grey Water Tank</i>	• 185
<i>Black Tank Flush</i>	• 185
TOILET	• 187
<i>Operating Instructions</i>	• 187
<i>Cleaning</i>	• 187
<i>Maintenance</i>	• 187
<i>Drain Traps &amp; Auto Vents</i>	• 188
COLD WEATHER USE	• 189
STORAGE - COLD WEATHER	• 189
WINTERIZING - Using Nontoxic Antifreeze	• 190
WINTERIZING - Using Air Pressure	• 191
TANK CAPACITIES - CHART	• 192
SERVICE CENTER	• 192





This section contains information and knowledge for the operation and care of the various water system equipment found in the motorhome. The motorhome is equipped with two separate water systems. Optional water equipment will also be discussed, so not all information may be applicable to the motorhome. More detailed information with **CAUTION** or **WARNING** instructions for the various equipment, other than what is found in this section, can be found in the manufacturer's manual in the owner information box.

It is hard to imagine how much water is used by the average person everyday. Newcomers to a self-contained motorhome soon discover water does not last very long unless consumption is drastically reduced. For example, less water can be used for showering if the shower is turned off while soaping down, then turned back on to rinse. This way a good shower uses a couple gallons of water or less. There is plenty of water to meet personal needs once habits are adjusted.

**Fresh Water System:**

The fresh water system consists of: fresh water tank, water pump, pressure accumulator tank, Manabloc Plumbing Manifold, gravity fill connection, water filters and a city/fresh water connection.

Use the water hose that is marked for potable water use only. Care of the hose is a must. **After each use, drain the water hose and coil the hose neatly. Attach the ends together to keep dirt, debris and insects out of the hose.**

**Waste Water System:**

The waste water system consists of: a waste holding tank (grey water), a sewage holding tank (black water), flush system, toilet and drains.

**WATER SYSTEMS - INTRODUCTION**

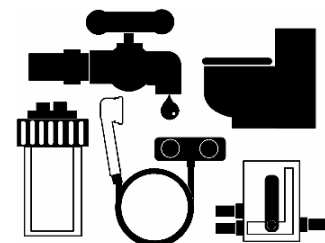

Watersys.eps

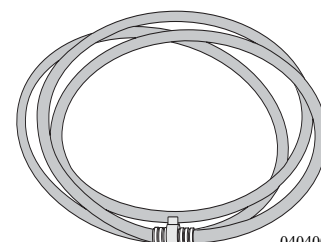

040400

The motorhome is equipped with a monitor panel to aide in managing the storage tanks. The monitor panel will be located in a main Status Monitor Panel in the hallway area. The switch marked **TEST** is a momentary switch which requires being held down while testing the level of the storage tanks. Read the scale for the desired storage tank that is to be monitored. Each scale uses colored lights along with a corresponding scale reading. The lights and scale indications are as follows:

- Green lamps indicate good or normal ranges.
- Amber lamps indicate fair or partial ranges.
- Red lamps indicate full or empty ranges (depending on the scale), which are in the critical range.

**Lamp indication voltages are as follows:**

6.0 Volt DC E lamp illuminates under 6.0 Volt DC lamp off.  
 Over 11.2 Volt DC the 1/3 lamp extinguishes.  
 Over 11.9 Volt DC the 2/3 lamp extinguishes.  
 Under 12.7 Volt DC the F lamp extinguishes.  
 All voltages have a +/- 5% tolerance.

**MONITOR PANEL  
Measurement  
& Calibration**

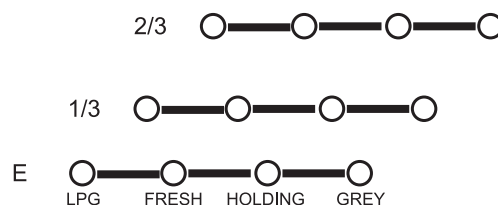

060158 zoom

## WATER TANK - FRESH WATER FILL



040460

- Connect a potable water hose to city/fresh water hook-up located in the service center on the roadside of the motorhome.
- Turn the city water/tank fill valve to the **FRESH WATER TANK FILL/OPEN** position.
- Turn on the water supply.
- The water pump should be in the **OFF** position.
- When the water tank is full water will flow out the vent opening of the gravity fill compartment. Shut the water supply off as soon as possible.



**NOTE:** When connecting the motorhome to fresh water be sure to use a hose manufactured and labeled for potable water to ensure that the hose will not flavor the water. Monitor the tank filling process at all times. Use the inside monitor panel as a tank fill guide.

## WATER - CITY HOOK-UP

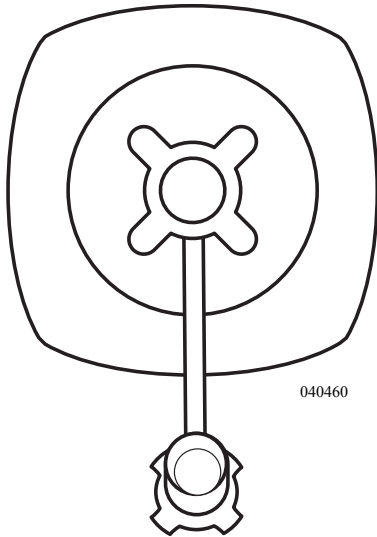

040460

- Connect a potable water hose to the city water hook-up located in service center on the roadside of motorhome.
- Turn the city water/fresh water tank fill valve to the city water position.
- Turn on the water supply.
- The water pump can either be off or on. It will not affect the water pump to leave it on.
- The city water hook-up in the service center does not have a pressure regulator or a one way check valve. A pressure regulator must be installed to limit incoming water pressure to no more than approximately 45 psi.



**CAUTION:** Some outside water sources develop high water pressure, particularly in mountainous regions. High water pressure is anything over 55 psi (pounds per square inch). Excessive water pressure may cause leaks in water lines and/or damage the water heater. Installing a pressure regulator at the city water faucet will regulate the pressure to the potable water hose. Excess pressure on a hot day can cause the water hose to swell and burst.

The water pump pressurizes the fresh water system when the motorhome is not connected to city water. The water pump is totally automatic and self-priming, operating on demand as water is used. The pressure equalizer tank relieves the water pump from cycling when a small amount of water is used. The water pump is located in a storage compartment of the motorhome.

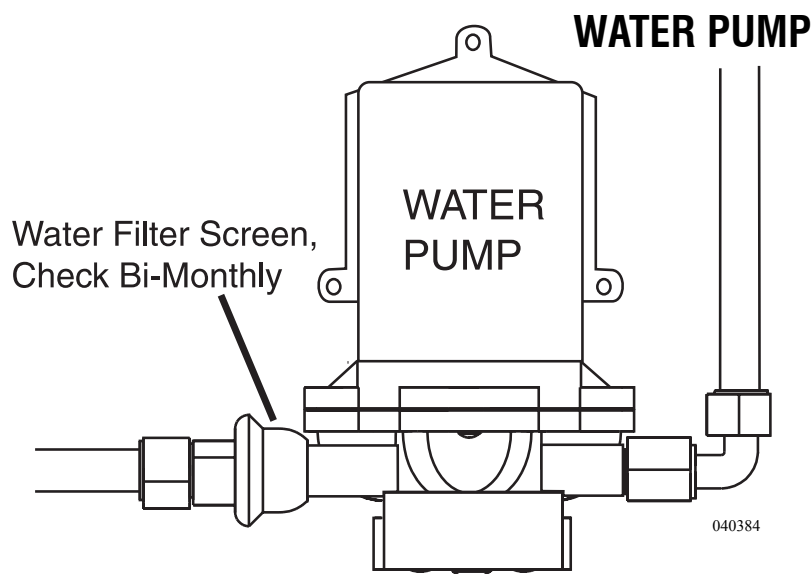

**WARNING:** Before leaving your coach for extended periods of time (i.e. overnight or longer) be sure that the city water and all water pumps have been turned off. Damage from neglect will be the responsibility of the owner, not the manufacturer.

The water pump may be operated from this location:

- The monitor panel.

To turn the water pump **ON** or **OFF**, momentarily press the water pump switch. The indicator lamp will illuminate when the water pump is turned **ON**.

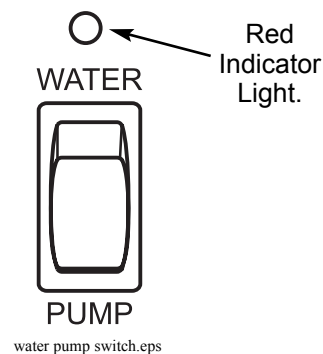

**CAUTION:** Do not continue water pump operation when the fresh water holding tank is empty. Damage to the water pump or electrical supply system may result.

**To start pump after unhooking city water supply, or first time use, proceed as follows:**

- Fill the fresh water tank.
- Open all valves and faucets except the drain valves. This includes hot and cold water valves, all faucets and shower.
- Turn the water pump on and wait for the water lines and the hot water tank to fill.
- Close each faucet when it delivers a steady stream of water (cold water faucets first).

## **Water Pump - Troubleshooting**

Vibration induced by road conditions can cause the plumbing or pump hardware to loosen. Check for system components that are loose. Many symptoms can be resolved by tightening the hardware. Check the following items:

### **The water pump will not start/blows the fuse:**

- Check the electrical connections, fuse or breaker, main switch and ground connection.
- Check the electrical connections at the latching controller.
- Is voltage present at the pressure switch? Bypass the pressure switch.
- Is the latching controller grounding the water pump?
- Check the charging system for correct voltage and good ground.
- Check for an open or grounded circuit or motor.
- Check for seized or locked diaphragm assembly (water frozen).

### **The water pump will not prime/sputters: (No discharge/motor runs):**

- Is the strainer clogged with debris?
- Is there water in the tank or has air collected in the hot water heater?
- Is the inlet tubing/plumbing sucking in air at plumbing connections (vacuum leak)?
- Check for proper voltage with the pump operating.
- Look for debris in the pump inlet/outlet valves or dry/swollen valves.
- Check the pump housing for cracks or loose drive assembly screws.

### **The water pump will not shut-off/runs when the faucet is closed:**

- Check to see if the fresh water tank fill valve is completely closed.
- Check output side (pressure) plumbing for leaks and inspect for a leaky toilet or valves.
- Look for loose drive assembly or pump head screws.
- Are the valves or the internal check valve held open by debris or is the rubber swollen?

### **The water pump is noisy or rough in operation:**

- Check for plumbing which may have vibrated loose.
- Does the mounting surface multiply noise (flexible)?
- Check for mounting feet that are loose or compressed too tight.
- Look for loose pump head to motor screws.

### **The water pump is rapid cycling:**

- Look for restrictive plumbing/flow restrictors in the faucets or shower heads.

## **WATER SYSTEM - Troubleshooting**

Water system problems and leaks usually fall into two categories: system problems and problems caused by improper use or lack of attention. These problems stem from improper winterizing, poor maintenance, road vibration and campsite water pressure variations. Check all plumbing connections for leaks at least once a year. If the water pump runs when a faucet is not open, check for a water leak. If a water line or fitting is leaking, tighten the fitting. Have the leak repaired before returning the supply line to service.



**NOTE: A small water leak can cause severe water damage. Shut off the water supply and have the leak repaired.**

If the hot water appears not to be heating to factory set temperature, check the faucet sprayer knobs located at the service center. Both faucets must be in the **OFF** position when not in use.

In addition, opening the city water/tank fill valve with the water pump off will remove all water line pressure within the motorhome.

Disinfecting the water system with chlorine bleach (superchlorination) protects the drinking water from bacterial or viral contamination that may come from any common water source.

## **WATER SYSTEM - Disinfecting Fresh Water**

### **Disinfect the Water System:**

- If the motorhome is new.
- If the motorhome has not been used in a long time.
- Every three months.



**NOTE: An independently operated water pump with garden hose connections and a container to hold prepared solution will be required to perform this task.**

**Use the following procedures to disinfect water system:**

- Prepare a chlorine bleach solution using 1 gallon water and 1/4 cup of chlorine bleach. Use 1 gallon of solution for every 15 gallons of tank capacity. Example: Add 2-2/3 gallons solution to a 40 gallon tank. Add 4-2/3 gallons solution to a 70 gallon tank. Add 6-2/3 gallons to 100 gallon tank. This mixture puts a 50 ppm (parts per million) disinfecting solution in the water system. This concentration will act as a quick-kill dosage for harmful bacteria, viruses and slime-forming organisms. Concentrations higher than 50 ppm may damage the water lines and/or tanks.
- Drain the fresh water tank. Close the drain and pump the solution (if desired) into the fresh water tank using an independently operated pump and a garden hose connected to City Water Hook-Up on the water control panel. Pour into the fresh tank using the gravity fill and a funnel. Run the water until you smell a distinct chlorine bleach odor.
- Allow the system to stand for four hours.
- Drain the system and flush with fresh water. The drain is located in the outside water service compartment. Install new water filters. Thoroughly flush with fresh water until no chlorine bleach taste or smell is detected in the water system.

---

**WASTE WATER  
SYSTEMS -  
Proper Waste  
Disposal**

Most State Parks have strict regulations about discharging wastes except into authorized disposal systems. Dumping raw sewage from toilet holding tanks, except at authorized dumping stations, is universally prohibited.

Most National, State and private parks have either a central dump facility or campsite hook-up for sewage. Many of the modern rest areas along the interstate now have dump stations available. You will find a list of dumping stations from coast to coast in Woodall's Campground Directory, Trailer Life's RV Campgrounds and Services Directory, Rand McNally's Campground and Trailer Park Guide, Good Sam Park Director (Good Sam Club), and other similar publications. Some major oil companies offer dump facilities at selected stations. With a little planning you will find few inconveniences in proper and legal disposal of holding tank waste.

**What Not  
to Put in Waste  
Holding Tanks**

- Do not use strong or full strength detergents to deodorize and disinfect. Use odor control chemicals made especially for holding tanks.
- Do not put automotive antifreeze, ammonia, alcohol or acetone in holding tanks. Some chemicals will dissolve plastic.
- Do not put large table scraps in the tanks. They could stick in or damage the valve seals.
- Do not flush facial tissues, sanitary napkins or other non-dissolving items into the system. Chemically treated for strength, the tissue will not dissolve like toilet paper. Special holding tank tissue is available at most RV supply stores. White toilet paper dissolves faster than colored paper.



**CAUTION: Do not use any products that contain petroleum distillate or ammonia in place of RV odor controlling chemicals. Petroleum distillate or ammonia will damage the ABS plastic holding tanks and seals.**



**NOTE: Never dispose of sanitary supplies or other non-dissolving items into the system. Facial tissue, wet strength tissue, paper towels or an excessive amount of toilet tissue can create clogging in the holding tank system.**

The waste drain system provides adequate and safe storage and/or discharge of waste materials. The drain system uses ABS plastic piping and fittings connected to sinks, shower, toilet and holding tanks draining to an outside termination. The motorhome should be reasonably level for optimum operation of the systems. The wastewater holding system consists of a wastewater holding tank (grey tank). The grey water tank stores the sink, shower and clothes washer drain water. A sewage holding tank (black tank) stores waste from the toilet only.

Drain valves and a tank flush system dispose waste through a common termination. Each holding tank has a separate drain valve dumping the waste water (grey water) and sewage (black water) through a common single discharge outlet. The tank drain valves are located service center on the roadside. Use the water monitor panel to observe tank levels. When ready to drain the tanks, drain the sewage tank first. Next, flush the black tank with the flush system. Drain the grey water tank. Using this sequence helps flush solids from the sewer hose. When traveling, it is recommend both holding tanks be empty or less than half full.

**Waste Drain &  
Sewage Tanks**

**Waste Drain Hose**

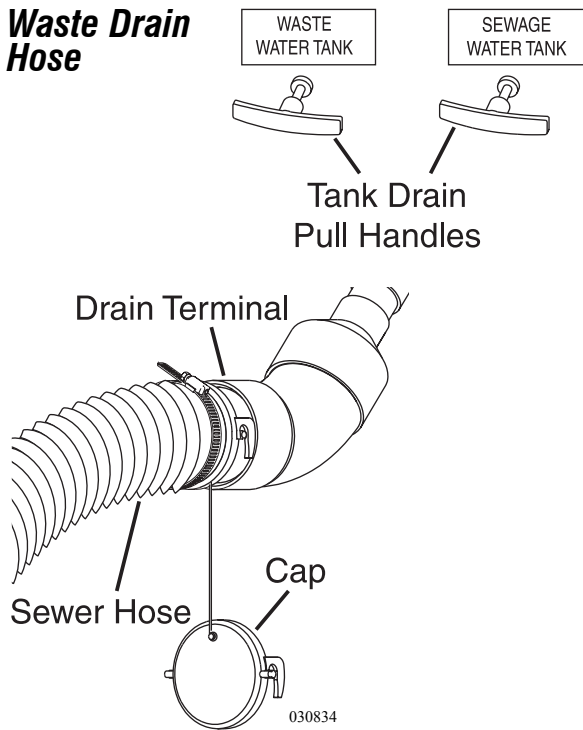

A flexible three inch sewer hose attaches between the termination drain and the shore facility. Sewer hoses usually come in 10 or 20 foot lengths. The sewer hose is stored in a tube accessed through a compartment door on the roadside next to the drain valves. The shore fitting for the sewer hose may be three or four inch pipe, which could be male or female thread. Another possibility may be a four inch pipe, with no threads, covered by a metal plate. There are many configurations. Different style adapters are available to fit most configurations. Hose ladders may also be purchased to support the hose.

It is important that the hose remains secure. Always tighten clamps and restraining devices before use. Lay the hose in line between the termination outlet and the shore fitting. Restrain the hose to prevent movement during use. Wear protective and/or disposable gloves when handling the sewer hose.

**To Attach the Hose:**

1. Remove sewer hose from carrier.
2. Remove termination cap. Align coupler tangs with termination tabs. Twist coupler clockwise 90° locking coupler to termination outlet.
3. Attach the other end of the hose to the drain service. Restrain hose to prevent movement during use.
4. Open the (small) grey water valve.

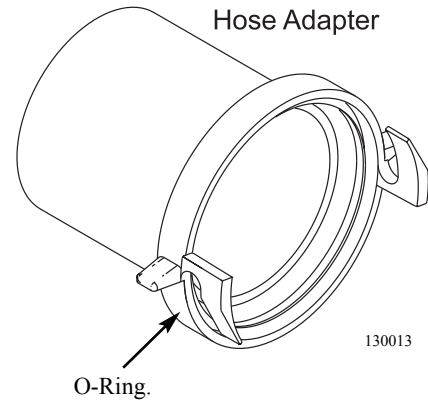

The (large) black water valve remains closed until the tank is full or until time of departure. This will help prevent accumulation of solids. Use the outside faucet or shower attachment for washing or rinsing.



**NOTE: Lubricate the O-ring on the sewer hose adapter periodically with silicone spray. Use care when connecting the sewer hose adapter to the termination outlet in cold weather.**



Before using the toilet, treat the sewage holding tank with water mixed with an odor-controlling chemical. These chemicals are readily available at most RV supply stores. Pour the chemicals into the holding tank through the toilet. Add approximately three gallons of water to the holding tank first. Next, mix the chemicals, in accordance with the manufacturer instructions, with approximately one gallon of water. Pour mixture through toilet to the holding tank. Be careful not to spill the chemical on your hands, clothing, toilet bowl or carpet as it can cause a permanent stain. Extremely hot weather areas may require adjusted amounts of chemical to help with odor control. Repeat the chemical pre-charge to the holding tank each time the tank is cycled.

### **What to Put into the Holding Tanks - Black Water Tank**



**CAUTION: Do not use any products that contain petroleum distillate or ammonia in place of RV odor controlling chemical. Petroleum distillates or ammonia will damage the ABS plastic holding tanks and seals.**

The grey water waste tank stores the sink, shower and clothes washer drain water. No chemical is required in this holding tank; however, a waste holding tank can produce odors. A reduced mixture of chemicals can help with odor control.

### **What to Put into the Holding Tanks - Grey Water Tank**

Ensure that there is enough liquid in the holding tanks prior to dumping the waste holding tanks. This provides a smooth flow through the valve, drain pipe and drain hose. When cycling the tank with sufficient liquid, a swirling action should remove accumulated solid wastes along with the waste liquid. Empty the sewage tank weekly to prevent stagnation and overflowing.

The motorhome comes equipped with a power flush system to aid in cleaning the holding tank. The power flush nozzle, located in the black tank, helps reduce solid build-up. Use the tank flush each drain cycle. Failure to thoroughly rinse the tank each drain cycle may result in solids accumulating and a clogged spray nozzle.

### **Black Tank Flush**



*Tank Flush Valve.*

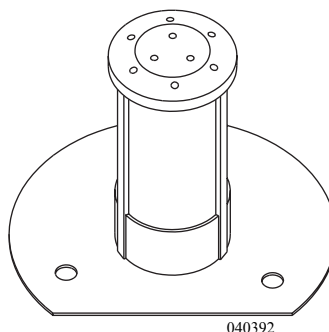

040392

**Dumping the Tanks:**

1. When preparing to dump the black tank, first close the grey water valve.
2. Fill the grey tank to at least 50% by running water in the shower or sinks.
3. Use the monitor panel to observe tank fluid levels. When the grey tank is 50% full stop filling the tank.
4. Open the black water valve. Allow the black tank to drain.
5. Use the tank flush system.
6. Connect a non-potable water hose, with pressure regulator, to the flush system fitting located in the service center.
7. Turn on the faucet allowing water to rinse the black tank at least three minutes. Never operate the system unattended. Ensure the water flows freely through the drain hose.
8. When completed turn off the faucet and close the black water valve.
9. Open the grey water valve. The water in the grey tank flushes any remaining solids from the hose. With the grey water valve open, run two gallons of water down any drain to flush the grey tank. The grey valve remains open until the next drain cycle or departure.



**WARNING: Never operate the flush system unattended. Flooding may occur. Use the tank flush system each time the holding tanks are cycled. Failure to routinely use the flush system will result in a clogged spray nozzle. Turn off the water supply when finished flushing the tank.**

10. If preparing for travel, close both the valves. Undo any restraining devices from the hose. Disconnect the hose from the termination outlet by rotating the fitting counterclockwise 90°.
11. Raise hose and drain using hand over hand method working hose towards shore fitting. Rinse the hose with outside facility and repeat the hose drain process.
12. Remove the hose from shore fitting. Install hose in carrier and lock door. Secure the termination cap (required by law in some states).
13. If desired, add chemicals to the tanks to control odor. Follow the chemical manufacturer's directions.



**NOTE: Dump the black tank before driving.**

The toilet operates from either fresh water tank or city water supply. The water pump must be turned on or the city water connected. The toilet flushes directly into a sewage holding tank (black water).

## **TOILET - Operating Instructions**

- To add water to the toilet before using press and hold the pedal half-way until the desired water level is reached. Generally, more water is required only when flushing solids.
- To flush the toilet press the all the way down.
- To operate the hand held sprayer, press and hold the pedal until water begins to flow into toilet. Press lever on hand held sprayer.

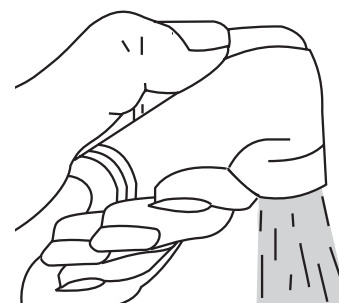

040397



**NOTE: Holding the flush pedal longer than necessary results in excess water use.**

The toilet should be cleaned regularly for maximum sanitation and operational efficiency. Clean the toilet bowl with a mild bathroom cleaner. Do not use chlorine or caustic chemicals, such as drain opening types, as they will damage the seals.

## **Cleaning**

Clean out the system by flushing several gallons of fresh water through with one cup of dry laundry detergent. Add odor control deodorant, in the amount specified for your holding tank capacity, after cleaning and every few days during use.

To find leaks, check behind or under toilet. Take four or five sheets of toilet tissue and wipe all the seams and water line connections. Start at the top of the unit and work downward. When the tissue comes in contact with leaking water it will immediately change texture.

## **Maintenance**



**NOTE: If the motorhome is in storage for six months it is a good idea to spray silicone on the toilet valve and work it back and forth. Perform this maintenance monthly (silicone will evaporate in about 30 days).**

**Checking for leaks:**

- Back of toilet: check water supply line connection.
- Between closet flange and toilet: Check screws for tightness. If leak continues, remove toilet and check flange height. Adjust, if necessary to 7/16" above floor. Replace flange seal if damaged.
- Poor flush: A good flush should be obtained within 2 to 3 seconds. If problem persists remove the water supply line and check flow rate. The flow rate should be at least ten quarts (9.5 liters) per minute.
- Bowl will not hold water: Check for foreign material in valve blade groove in the flush drain.



**NOTE: Most chemical mixtures for holding tank odor control are poisonous. Follow the product manufacturer's directions and warnings when using any holding tank additive.**

**Drain Traps & Auto Vents**

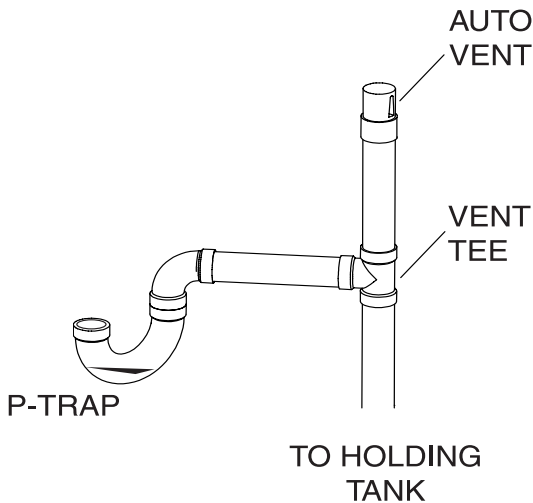

Sinks, shower and clothes washer drains incorporate a water trap or "P-trap" and auto vents to prevent waste water holding tank odor from entering the motorhome. These P-traps are usually within 54" of a vent tee. These traps must have water in them to block odors.

During storage water can evaporate and allow odor into motorhome. If odor is detected run water into sinks, shower and clothes washer to fill drain traps. The auto vent by design is to assist in the flow of water in the drain lines. They enable a smooth flow of water in the drain without creating a vacuum.

If the auto vent is stuck in the open position, grey odors may enter the motorhome. Auto vents double as "clean outs" in case the line has to be "snaked" out.



**NOTE: Most chemical mixtures for holding tank odor control are poisonous. Follow the product manufacturer's directions and warnings when using any holding tank additive.**



**NOTE: During cold weather antifreeze must be added to the drain traps.**

**COLD WEATHER  
USE**

A motorhome is not designed for extended use in below freezing (32° F/0° C) weather. However, you may not experience any problems as long as the temperature does not drop too low. Interior water lines, fixtures, water storage tanks and pumps are normally protected from moderate freezing temperatures, as long as the furnace is operating. Exposed drains may freeze quickly. If in doubt about what temperature the motorhome will tolerate, winterize with potable antifreeze.

**Storage:**

If the motorhome is stored where freezing temperatures may occur, drain the domestic fresh water loop completely of water. When draining the domestic fresh water system begin with draining the fresh water tank by opening the point drain lever for the fresh tank and allowing the water to drain.



**NOTE: Ice makers, water purifiers (if applicable) and water heaters all use domestic water and should be drained and stored in accordance with the manufacturer's recommendation for winterizing.**

The method chosen to winterize the motorhome and water lines is up to the motorhome owner. The lines can be air blown to remove standing water or the lines can be filled with approved FDA RV antifreeze. Either way, all interior and exterior faucets need to be opened and closed, one at a time, to be checked. Open all low point drains and drain the holding tanks.

If the motorhome is stored where freezing temperatures may occur, drain the domestic fresh water loop completely of water. When draining the domestic fresh water system begin with draining the fresh water tank by opening the point drain lever for the fresh tank and allowing the water to drain.

**STORAGE  
- COLD WEATHER**

**NOTE: Ice makers, water filters, water purifiers and water heaters all use domestic water and should be drained and stored in accordance with the manufacturer's recommendation for winterization.**

The method chosen to winterize the motorhome and water lines is up to the motorhome owner. The lines can be air blown to remove standing water or the lines can be filled with an approved FDA RV antifreeze. Either way, all interior and exterior faucets need to be opened and closed, one at a time, to be checked. All low point drains should be opened and the holding tanks emptied.

## **WINTERIZING - Using Nontoxic Antifreeze**

Ten gallons of FDA approved RV antifreeze will be required to winterize the motorhome.

- Open all faucets, low point drains (next to the Aqua-Hot) and drain valves for the fresh water tank, water heater tank, holding tanks and fresh water lines.
- Close all faucets, drain valves and low point drains.
- If the motorhome has a water heater, remove the anode to drain the internal tank. At the back of the water heater turn the water valve to the "by-pass" mode.
- Pour the antifreeze into the fresh water tank using the fresh water gravity fill.
- Turn ON the system water pump and operate each faucet (hot and cold valves) individually until a small amount of antifreeze is present.
- Close off the faucets.
- Open the shower faucets and toilet valve to allow a small amount of antifreeze to run into the holding tanks.
- Use a soft cloth to wipe out the sinks and shower to protect surfaces from antifreeze stains.
- Open the exterior faucet using the same procedure as the interior faucets.
- If the motorhome is equipped with an icemaker, remove the  $\frac{3}{4}$ " fitting and flush antifreeze through the water line.
- Disconnect the power supply line affecting water pump operation.

To de-winterize, drain and fill the fresh tank with water. Connect the power supply line for the water pump. Operate all faucets, one at a time, until clear water is present.



**WARNING: Use only specifically designed non-toxic RV antifreeze for potable water systems. Automotive antifreeze, if ingested, can cause blindness, deafness or death.**



**WARNING: It is recommended that a qualified RV service technician familiar with motorhomes, such as an authorized dealer, do this procedure.**

**WINTERIZING**  
**- Using Air Pressure**

To use air pressure to winterize the motorhome you will need access to an air compressor and an adapter to connect the air line to the water system. Adapters can be found at any RV supply store. When hooked to the water lines the pressure should not exceed 40 psi. Higher pressure can damage the lines.

- Drain the fresh water tank by opening the valve located in the outside water control service compartment of the motorhome.
- Open the water heater and the low-point drains. Turn knobs to open the drains.
- Open the low point drains to clear the water out of the hot and cold water lines. Leave the low-point valves open until the motorhome is used again.
- Let all the water drain. Turn the pump on and allow it to run so that all the water is cleared out of the pump and lines. Turn the pump off.
- After the water lines are drained, hook an air hose to the city water connection located on the water control panel in the outside service compartment. Blow out the water lines until no further water can be seen coming out of the drain lines. Do not exceed 40 psi in the water lines and faucets
- Open all faucets (including the outside spigot), one at a time while the air is on, to clear water from the faucet supply lines. Do not forget to drain the shower.
- While the air is on, hold the spray nozzle (located right next to the toilet) open until the water has quit running. Hold the toilet flush pedal or handle down until the water has stopped running.
- Unhook the air hose and close the city water connection.
- You will need 1 gallon of RV antifreeze to protect various water drain lines in the motorhome. Pour 1 pint into both the kitchen and bath shower drains. Pour 2 pints into the bath sink drain, with some of the antifreeze going into grey tank to protect the drain valve. While holding down the flush pedal, pour another 3½ pints into the toilet, letting the antifreeze run into the black tank to protect the valve located there. Pour the last pint of antifreeze into the toilet after you have released the flush pedal. Use a soft cloth to wipe out the sinks and shower (after the antifreeze is poured in) to protect the surfaces from stains.
- Leave the low-point drains open until the motorhome is used again.



**WARNING: When draining the low water drain lines and the water heater be sure the water is not hot. Hot water from the lines can burn or injure skin.**

## TANK CAPACITIES - CHART

Water Tank Capacities	3996	3756
Water Heater	6 gal.	6 gal.
Water Heater Opt.	10 gal.	10 gal.
Grey Tank	55 gal.	55 gal.
Black Tank	55 gal.	55 gal.
Fresh Tank	95 gal.	95 gal.



**NOTE:** This chart reflects product specifications available at the time of printing. Therefore any floor plans introduced thereafter may not be reflected in the chart. All other information contained throughout the manual will still apply.

## SERVICE CENTER

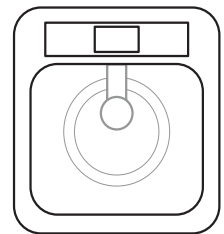

### WARNING

POTABLE WATER ONLY. SANITIZE, FLUSH AND DRAIN BEFORE USING. (SEE INSTRUCTION MANUAL)



CITY WATER HOOKUP

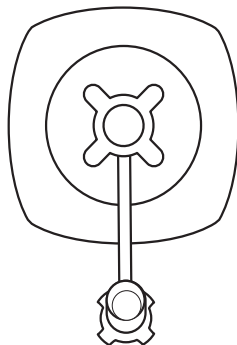

BLACK TANK DRAIN

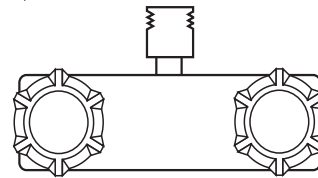

FRESH WATER TANK FILL

GREY TANK DRAIN

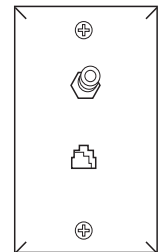

TV AND PHONE HOOKUP



LOW POINT DRAIN



LOW POINT DRAIN



# SAHARA

SECTION 7  
LP-GAS SYSTEMS

LP-GAS SYSTEM •	195
LP-GAS DETECTOR •	196
<i>Operation</i> •	196
<i>Testing</i> •	196
<i>Alarm</i> •	197
<i>Care of the Detector</i> •	197
MONITOR PANEL MEASUREMENT •	198
CHECKLIST - LP-GAS EMERGENCY PROCEDURES •	198
LP-GAS TANK CAPACITY •	199
LP-GAS TANK •	199
<i>Operation</i> •	199
<i>LP-Gas Tank Filling</i> •	200
LP-GAS FUNDAMENTALS •	200
LP-GAS REGULATOR •	202
LP-GAS HOSE INSPECTION •	203
LP-GAS CONSUMPTION •	204
LP-GAS DISTRIBUTION LINES •	205
LP-GAS SAFETY TIPS •	206

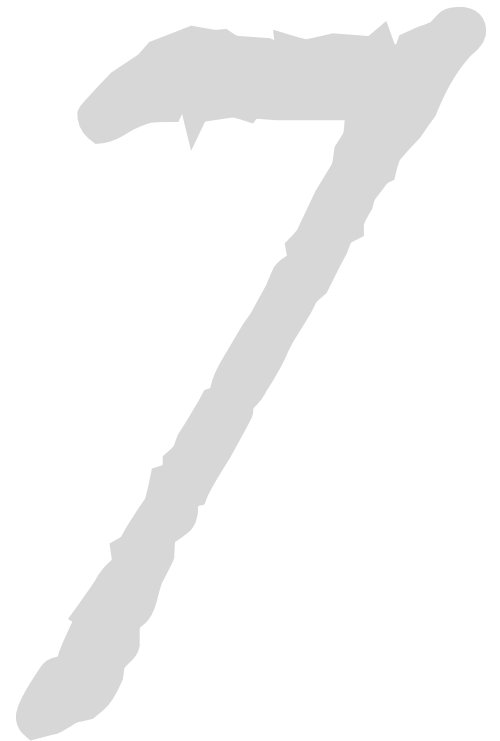



**LP-GAS SYSTEM**

This section contains information and knowledge for the operation and care of the various Liquefied Petroleum (LP-Gas) system equipment found in the motorhome. The motorhome is equipped with several appliances and various equipment which are capable to operate on LP-Gas. Some items discussed may not be applicable to all motorhomes. More detailed information with **CAUTION** or **WARNING** instructions for the various equipment, other than what is found in this section, can be found in the manufacturer's manual in the owner's information box.

All components for the motorhome LP-Gas systems are approved for use in recreational vehicles by a nationally recognized testing laboratory. When properly handled, LP-Gas is a clean-burning dependable fuel for heat producing components. The LP-Gas tank mounted in the motorhome contains liquid petroleum gas that is under high pressure. As the fuel is used, liquid gas vaporizes and passes through the tank valve to a regulator that automatically reduces pressure. Low-pressure gas is then distributed to components through a pipe manifold system.

Component lighting problems are commonly caused by an improperly adjusted gas regulator. Do not attempt to reset the regulator. Adjustments need to be made by a dealer or an authorized service person.

In higher elevations or extreme cold weather (10° F/-21° C or lower) a shortage of LP-Gas may be experienced. Usage can be modified by running only one component at a time. For example, turn off the furnace while using the range. If LP-Gas is going to be used in higher elevations or cold climates for a long period of time, have an authorized service person adjust the LP-Gas regulator for these conditions.

Have the LP-Gas system checked by an authorized dealer at least once a year, and thereafter before every extended trip. Although the manufacturer and the dealer test the system carefully for leakage, travel vibrations can loosen fittings.

Leaks can be easily found by applying a leak detector solution on all connections. Leaks can usually be repaired by tightening the fittings. If not, shut off the main gas valve at the tank. Immediately see an authorized dealer for repairs. Hand tighten the tank valves only. Do not use a wrench or pliers as over tightening may damage valve seats and cause leaks. If a leak is suspected (which can be easily identified by the odor of rotten eggs or sulfur) never light a match, have an open flame or use any spark producing equipment or appliance.



**WARNING: LP-Gas is highly volatile and extremely explosive. Do not use matches or a flame to test for leaks. Use only approved LP-Gas leak testing solution for leak detection. Unapproved solutions can damage copper tubing and brass fittings. Never attempt to adjust LP-Gas regulators. Only qualified personnel should perform any maintenance or repair to the LP-Gas system.**

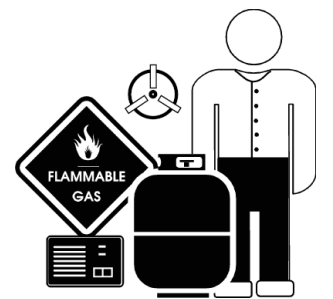

Lp 2.eps

## LP-GAS DETECTOR

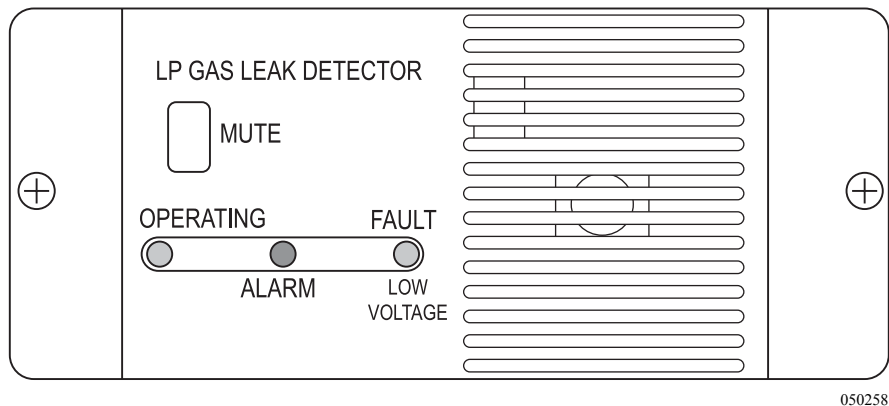

The LP-Gas detector is provided for safety. It detects both LP-Gas and methane gas. Liquefied Petroleum (LP) Gas is heavier than air; methane gas is lighter than air. LP-Gas will settle to the lowest point, generally the floor of the motorhome. Methane gas will rise. The gas detector is also sensitive to other fumes such as hair spray, of which most contain butane as the propellant.

Butane, like propane, is heavier than air and will settle to the floor level where it will be detected. When this occurs, press reset button to stop the alert sound for 60 seconds.

Other combustibles which will be detected include alcohol, liquor, deodorants, colognes, perfumes, wine, adhesives, lacquer, kerosene, gasoline, glues, most cleaning agents and propellant of aerosol cans. Most are lighter than air in their vapor state and will only be detected when the motorhome is closed up.

### Operation

Upon first application of power the LED will flash **yellow** for three minutes while the detector is stabilizing. At the end of the start cycle the LED will turn **Green**, indicating full operation. If the detector senses unsafe levels of gas it will immediately sound an alarm. The gas detector operates on 12 Volt DC, with a current draw less than 1/10th of one amp.



**CAUTION: The detector will not alarm during the three minute warm up cycle.**

### Testing

Press the **TEST** switch any time during the warm up cycle or while in normal operation. The LED should flash **red** and the alarm should sound. Release the switch. This is the only way the detector should be tested. The test feature checks full operation of the detector.



**WARNING: Test the operation of this detector after the motorhome has been in storage, before each trip and at least once per week during use.**

The **red** LED will flash and the alarm will sound whenever a dangerous level of propane or methane gas is detected. The detector will continue to alarm until the gas clears or the **TEST/MUTE** switch is pressed.

**Procedures To Take During An Alarm:**

1. Turn off all gas appliances, (stove, heaters, furnace), extinguish all flames and smoking material. Evacuate, leave doors and windows open.
2. Turn off the propane tank valve.
3. Determine and repair the source of the leak. Seek professional help if necessary.



**CAUTION: Do Not re-enter until the problem is corrected.**

**Alarm Mute:**

Press the **Test-Mute** button when the detector is in alarm.

1. The **red** LED will continue flash and the alarm will beep every 30 seconds until the gas level has dropped to a safe level.
2. The LED will flash **green** until the end of the **MUTE** cycle.
3. If dangerous gas levels return before the end of the **MUTE** cycle, the alarm will beep four times and return to phase 1.
4. After two minutes the detector will return to normal operation (**solid green**) or resound the alarm if dangerous levels of gas remain in the area.

**Fault Alarm:**

Should the microprocessor sense a fault in the gas detector, a fault alarm will sound twice every 15 seconds. The LED will alternately flash **red** to **green** and the **MUTE** switch will not respond to any command. The gas detector must be repaired or replaced.

1. Vacuum the dust off the detector cover weekly (more frequently in dusty locations) using the soft brush attachment of the vacuum.
2. Do not spray cleaning agents or waxes directly onto the front panel. This action may damage the sensor, cause an alarm or cause a detector malfunction.

**Care of  
the Detector**

## MONITOR PANEL MEASUREMENT

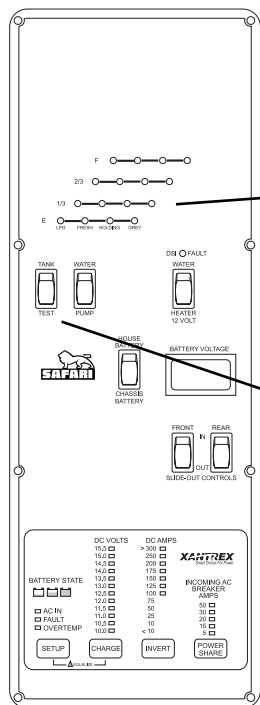

Sahara Monitor Panel.eps

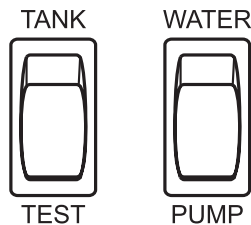
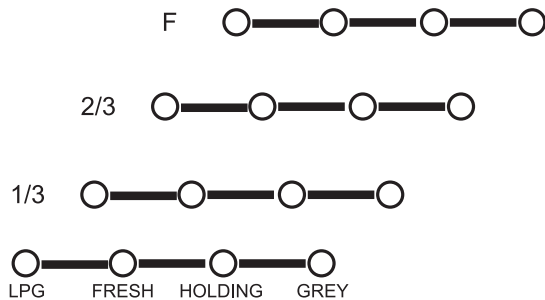

Use this switch to test tanks.  
Momentary push & hold.

**Tank Measurement** - To measure level of a tank simply push button on display panel corresponding to tank you wish to measure. Observe the gauge.

**Calibration** - The monitor panel comes factory calibrated for accuracy and should not need to be adjusted.

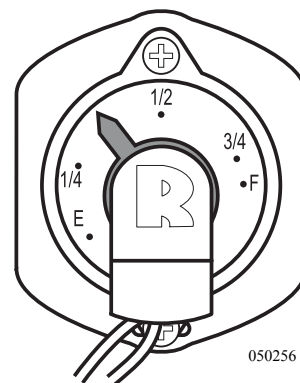

LP Tank Gauge

050256



**NOTE: The LP-Gas gauge is not adjustable.**

## CHECKLIST- LP-GAS EMERGENCY PROCEDURES

If you smell gas (a rotten egg or sulfur smell) at any time, perform the following steps immediately:

- Shut off gas appliances.
- Manually turn off the main gas supply at the tank.
- Do not attempt to operate any electric switch as this can produce a spark and ignite the gas.
- Open windows and doors.
- Evacuate the motorhome. Stay clear of the surrounding area.
- Keep open flames, spark producing devices and smoking material out of the area.
- Contact a qualified service technician to find the source and repair the gas leak.



**WARNING: A fire or explosion from ignited gas or gas fumes can seriously injure you or cause death.**

**LP- GAS TANK CAPACITY**

LP-GAS TANK CAPACITY	
3996	41 Gallon
3756	41 Gallon

**LP-GAS TANK - Operation**

LP-Gas exists in both the liquid and vapor state within the LP-Gas tank. A “FULL” tank is approximately 80% liquid. The pressure inside the tank varies with the temperature of the liquid. All tanks are required to be equipped with a pressure relief device. The purpose of the relief valve is to release gas or liquid caused by being overpressurized. The gauge at the tank, when full, will only read 3/4 full. The monitor panel is adjusted to indicate “FULL” at this point.

When storing portable LP-Gas tanks that are not connected to an LP-Gas system, install an approved plug in the tank outlet holes to prevent leaks. Do not transport or store LP-Gas tanks, gasoline or other flammable liquids inside the motorhome.



**WARNING:** Do not store or transport empty LP-Gas tanks, portable tanks, gasoline or other flammable liquids inside the motorhome. Keep open flame and spark producing materials away from the LP-Gas area. Shut off all appliances and LP-Gas tank valve (located on side of LP-Gas tank underneath the motorhome) when the motorhome is in storage. If this warning is ignored a fire or explosion could result.



**CAUTION:** Pressure inside LP-Gas tanks can reach over 200 psi when exposed to direct sunlight. A high pressure safety relief valve will purge excess high pressure if necessary. LP-Gas will stop vaporizing as the LP-Gas tank temperature approaches -40° F. Appliances that consume large amounts of LP-Gas, such as the water heater or furnace, will need to be operated in sequence in extremely cold environments.

**Tank Operation:**

- Manually open the primary shut-off valve located on the LP-Gas tank.
- Turn off the primary valve on the LP-Gas tank when the motorhome is in between trips.
- Hand tighten the primary valve. Do not use a wrench or pliers to close the valve.
- The primary valve is designed to be closed by hand, over tightening may permanently damage the valve seat.

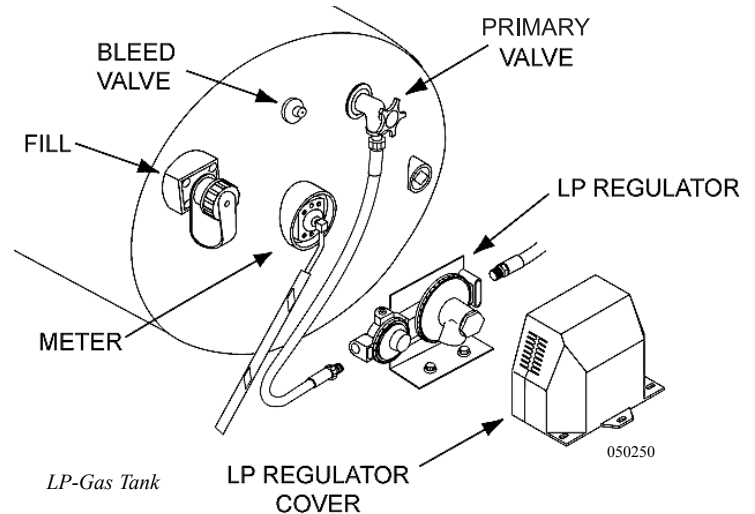

## LP-Gas Tank Filling

*Woodall's Campground and Trailer Guide* and other similar publications list refueling stations. Many travel parks sell LP-Gas. Shut off the pilot lights, appliances and igniters before filling the LP-Gas tank to prevent a fire or explosion. Have a trained service person fill the LP-Gas tank.

The LP-Gas tank fill is located in the LP-Gas tank access outside compartment. Caution the service technician, if the tank is new and being filled for the first time, to purge any air from the tank before filling. When the tank is filled to the proper level there is space available for the conversion of liquid into gas. If a tank is over-filled it may vent pressure. When this happens a strong rotten egg odor near the tank and/or hear a hissing noise may be detected.



**WARNING: Turn off all pilot lights and appliances while filling the LP-Gas tank to prevent a fire or explosion.**



**NOTE: Actual tank capacity is 80% of listing.**

## LP-GAS FUNDAMENTALS

# Capacity	Gallon Capacity	BTU Capacity
5	1.18	107,903
10	2.36	215,807
11	2.59	237,387
20	4.72	431,613
30	7.08	647,420
40	9.43	863,226

### CONVERSIONS

Gallons to Liters (1 Gallon = 3.785 Liters)

Fahrenheit to Celsius ( $F^{\circ} - 32 \div 1.8 = C^{\circ}$ )

11 in. Water Column = 6 1/4 ozs. per sq. in. pressure.

27.7 in. Water Column = 1 lb. per sq. in. pressure.

**The above capacities allow for 20% vapor space on each cylinder.**

*Data taken from the National Fire Prevention Association (NFPA). Pamphlet #58-1998.*



**LP-Gas Statistics:**

Pounds Per Gallon	4.24
Specific Gravity of Gas	1.50
Specific Gravity of Liquid	.504
Cubic Feet Gas Per Gallon of Liquid	36.38
Cubic Feet Gas Per Pound	8.66
BTU Per Gallon	91,502
BTU Per Pound	21,548
Dew Point in Degrees Fahrenheit	- 44° F
Vapor Pressure at 0° F	31
Vapor Pressure at 70° F	127
Vapor Pressure at 100° F	196
Vapor Pressure at 110° F	230
Flash Point	842° F

**Basic Facts About LP-Gas:**

- LP-Gas detectors are a federal requirement on all LP-Gas equipped recreation vehicles.
- LP-Gas is a by-product produced by refining oil.
- Odor is added to LP-Gas after the refining process.
- Each liquid gallon of LP-Gas produces 91,502 BTU (British Thermal Units).
- Temperature effects pressure of LP-Gas.  
Internal tank pressure can exceed 200 psi.
- Tanks or valves contain pressure relief valves.  
The relief valve opens at 125% above tank rating.
- LP-Gas stops vaporizing at -44° F.
- Standard LP-Gas operating pressure is 11" of Water Column or approximately 6 ¼ ounces per square inch.
- An inch of Water Column is a measurement of applied pressure to one side of a U-Tube ½ filled with water at sea level. The amount of pressure required to raise the water level 11", represents 11" of Water Column.



**NOTE: The above information is not a complete guide for the use of LP-Gas tanks or appliances. In cold climates keep fuel levels above 50% in order to keep vaporization of LP-Gas at the highest level.**

## LP-GAS REGULATOR

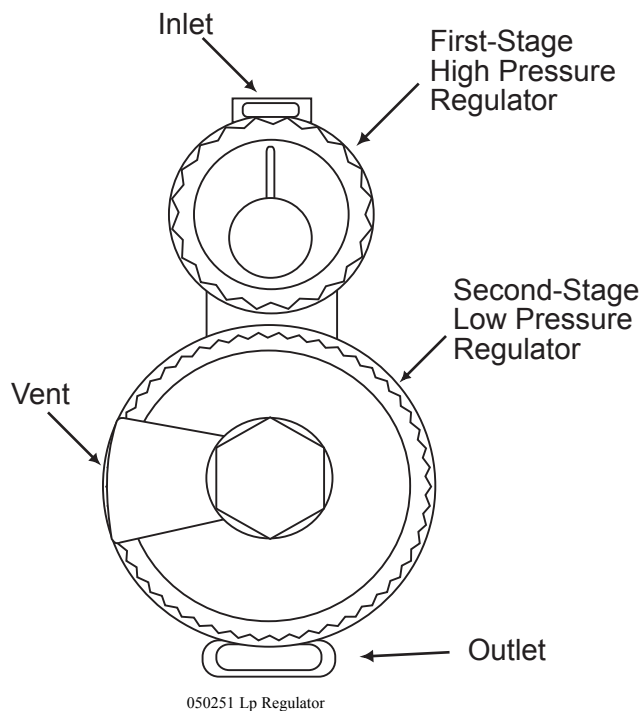

Typical two-stage LP-Gas Regulator.

The regulator is the heart of an LP-Gas system. The LP-Gas in the tank is under high pressure. The regulator reduces the pressure of gas so that it is safe to use with various appliances. The regulator on the motorhome is a two-stage regulator. The first stage regulator reduces the full tank pressure down to a range of 10-13 psig (pounds per square inch gauge). The second stage further reduces the pressure down to an outlet pressure of 0.4 psig (11 inches of water column). The regulator is equipped with a vent that allows it to breathe. It is important to keep the vent clean and clear of obstructions or corrosion. If the vent becomes clogged, pressure from LP tank could cause a failure of the components. If there is any corrosion, contact a qualified LP-Gas service technician. The regulator is mounted so that the vent faces downward. If the vent becomes clogged clean it with a toothbrush.

Under normal atmospheric conditions an LP regulator will not freeze, nor will the LP-Gas. The gas passing through the regulator will expand and cool creating moisture in the gas. This moisture will turn to ice which can build up and partially or totally block the orifice. The possibilities of freeze up is greatly reduced with the two stage regulator.

### To prevent freeze up:

1. Ensure the LP tank is totally free of moisture prior to filling.
2. Ensure the tank is not overfilled.
3. Keep the valve closed when the tank is empty.
4. If a freeze up occurs, have an LP-Gas distributor purge the tank.
5. Have the LP-Gas distributor inject methyl alcohol in the tank.



**WARNING: Do not attempt to adjust the regulator, it is preset at the factory. If adjustments need to be made, special equipment is required. Failure to follow these instructions may result in a fire or explosion and cause severe personal injury or death. Do not attempt to enter the motorhome until the problem has been corrected!**

It is suggested by the hose manufacturer, that the Liquid Propane Gas (LP-Gas) supply hoses used on the motorhome, be subject to regular inspections. As a guideline, we suggest that all flexible LP lines connecting the slide-out, appliances, or tanks be inspected in the spring and fall of each year by a qualified RV technician.

According to the manufacturer, the inspections should consist of the following procedures and be performed when the hose is not under pressure:

1. Inspect the outside cover of the hose for blistering, abrasion or cuts and coupling slippage. Cuts in the hose cover, which expose or damage the reinforcement, are cause for replacement. Hose strength is controlled by the plies of the reinforcement and, for this reason; damage in this area cannot be tolerated. Small cuts, nicks, or gouges in the cover that do not go completely through the cover will not be cause for replacement of the hose.



**NOTE: Pricking of the cover in the manufacture of this type of hose is common and necessary for satisfactory hose performance; Consequently, the uniformly pricked cover should not be viewed with alarm.**

2. Damage to the textile reinforcement or wire braid is cause for hose replacement. Wire braid reinforced hose, which has been kinked or flattened, so as to permanently deform the wire braid in the un-pressurized state, shall be removed from service.
3. Blistering or loose outer cover is cause for hose replacement.
4. Examine couplings for slippage. Slippage is evidenced by the misalignment of the hose and coupling and/or the scored or exposed area where slippage has occurred. Any evidence of slippage is cause for hose replacement.
5. It is important that if a damaged LP-Gas hose is found, the source of the damage be determined and corrected prior to the replacement of the LP-Gas hose.



**NOTE: Only a qualified RV technician should complete replacement of LP-Gas components.**

It is also suggested, that the flexible LP-Gas supply lines on your recreational vehicle be replaced every ten (10) years. The manufacturer of the LP-Gas supply lines recommended this schedule after performing extended testing and have determined that the failure rate may rise after this period of time. The motorhome manufacturer recommends following these guidelines to assure your continued safety and the dependable use of your recreation vehicle.

## LP-GAS CONSUMPTION

Each gallon of LP-Gas produces 91,502 BTU's of heat. One 27 gallon tank produces two million BTU's. Total consumption depends on the rate of usage by each appliance and the operating time. The stove and heating systems typically use the most gas. With sub-freezing temperatures and high winds, consumption by the furnace can be very high. Check the tank level often in cold weather.

### Determine Fuel Consumption:

To determine approximately how many hours an LP-Gas appliance will operate on one gallon of LP use the following formula:

- LP-Gas appliances are rated in Input BTU (British Thermal Units). The rating is usually stamped or printed on tag affixed to the appliance. For example: the Input rating of the appliance is 10,000 BTU's.
- One gallon of LP-Gas produces 91,502 BTU's.
- Divide the amount of BTU's of one gallon of LP-Gas (91,502) by the rating on the appliance in this example 10,000. Net continuous operation time for one gallon of LP-Gas for this appliance would be approximately 9.2 hours.

Typical Appliance BTU Ratings
<b>Water Heater (Suburban)</b> 6 gallon - 12,000 BTU 10 gallon - 10,000 BTU
<b>Furnace (Atwood)</b> 40,000 BTU
<b>Cooktop</b> 9,000 BTU - Front 6,500 BTU - Rear 7,100 BTU - Oven
<b>Refrigerator (Norcold)</b> 2-door 1500 BTU 4-door 2200 BTU

The above formula can be useful when trying to determine the approximate length of time a tank of LP-Gas will last. Generally, LP-Gas appliances do not operate continuously. An example would be the typical cycling of the furnace or water heater.

### Determining how long a tank of LP-Gas will last:

- Combine the BTU input totals of all appliances and the approximate length of time these appliances operate per day.
- Multiply the number of liquid gallons in the LP tank by 91,502.
- Divide the total of BTU's of the LP tank by the total number of BTU's the appliances consume equals the approximate number of hours of operation before refueling.



**WARNING: LP-Gas is highly volatile and extremely explosive. Never use matches or open flame to test for leaks. Use only approved LP-Gas leak testing solution to test for leaks. Unapproved solutions can damage copper tubing and brass fittings. Never attempt to adjust LP-Gas regulators without the use of proper equipment. Improper LP-Gas regulator adjustment will affect the performance of LP-Gas operated appliances. Incorrect flame or explosion can occur. Only qualified personnel should perform any maintenance or repair to the LP-Gas system.**

# LP-GAS DISTRIBUTION LINES

A primary manifold black steel pipe running throughout the motorhome distributes LP-Gas to secondary lines. All secondary lines leading to gas appliances are made of copper tubing with flared fittings. If any lines rupture do not attempt to splice them. Always run a new line. We recommend gas distribution work be performed by an authorized dealer or an authorized service technician. When removing or servicing any gas appliance, manually close the main valve located on the side of the LP-Gas tank. This will prevent dangerous gas leakage that could result in an explosion and possible serious injury.



**INSPECTION:** Inspect the rubber flexible lines, twice a year, for abrasions, tears, kinks or other signs of damage.

If a gas leak is suspected, get the system inspected and repaired by a qualified service technician as soon as possible.

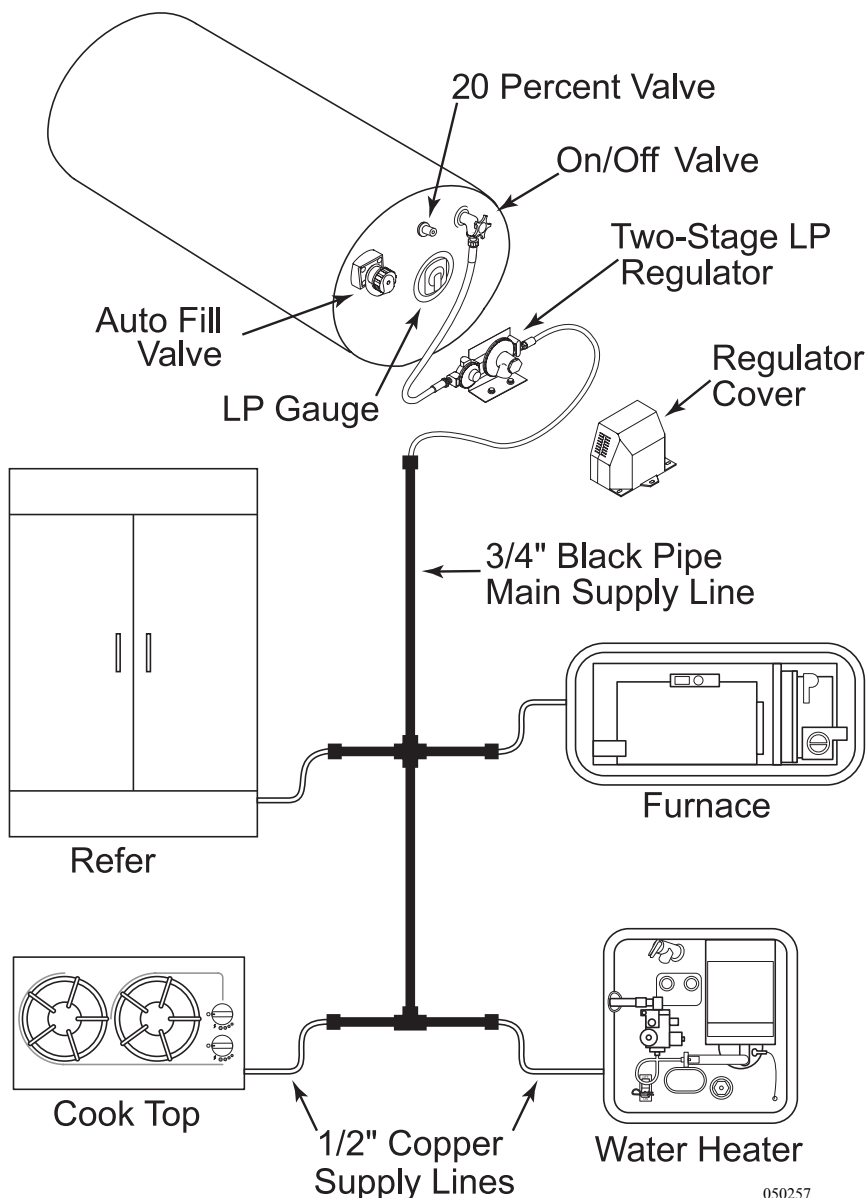

## **LP-GAS SAFETY TIPS**

Liquid Propane gas is one of the safest and most reliable fuels available on the market if it is handled properly. LP-Gas, however, does have a great explosive "potential" if handled improperly. Danger is minimized by becoming familiar with and following a few safety precautions, and by learning how to properly operate LP-Gas appliances. Use of LP-Gas requires the responsibility to enforce extra safety measures.

The motorhome is equipped with many LP-Gas operated appliances because it is a convenient and efficient source of fuel. LP-Gas appliances must be operated and maintained in accordance with the product manufacturer's instructions.

The National Propane Gas Association (NPGA) has a special service program offered called GAS<sup>®</sup> (Gas Appliance System) Check. The GAS<sup>®</sup> Check program is aimed at educating the users in the association about the convenience of propane use with safety and peace of mind. For information on the **NPGA Gas<sup>®</sup> Check program, call (630) 515-0600 or visit [www.npga.org](http://www.npga.org).**

### **LP-Gas Tanks and Cylinders:**

Tanks are built to American Society of Mechanical Engineers (AMSE) Code. The cylinders are built to DOT (Department of Transportation) Code. The major difference between cylinders and tanks is in required testing and inspection procedures and in the construction of the containers. Both tanks and cylinders are required to undergo pressure testing and inspections; however, the procedures for how they are tested and inspected differ.

The difference between the two codes are that the valves, fittings and brackets are located only on the ends of the DOT cylinders; however, on the ASME tanks they may be located on ends, as well as the sides. There is also a difference in how the tanks are rated. Required tank ratings are in gallons (ASME ratings) or pounds (DOT) water capacity. The Federal DOT (Department of Transportation) regulations require periodic inspections and re-qualifications of cylinders.

American Society of Mechanical Engineers (AMSE) tanks or bulk containers are generally used in the motorhomes and motorized products. These tanks are permanently mounted on to the unit.

An alloy steel two-piece welded and brazed tank is used on all towable products. The marking on the collar, DOT 4BA240, identifies the DOT specifications and service pressure. Other pertinent information included on the collar is the water capacity (WC) and the tare weight (TW), both which are measured in pounds, and the Manufacture date (one of the most important items). There is a required 12 year re-qualification. The final piece of information is for the Dip Tube (DT) length. This is part of the overfill protection and maximum liquid allowance in the cylinder.



**Maintenance and Safety Tips for the LP-Gas Refrigerator:**

- Have the refrigerator, furnace and venting **inspected** annually by an authorized service center.
- Before firing up the refrigerator, or using the propane gas furnace for the first time each season, have the venting system checked for blockage. Insects may have built nests that will obstruct flow.
- At the first indication of incomplete combustion (yellow flame instead of a blue flame or soot is present) contact a service technician immediately. Improper combustion can cause carbon monoxide buildup, which is potentially fatal!

**Maintenance and Safety Tips for the Propane Range:**

- Burner flame should be a blue color, indicating complete combustion. If not, have the unit serviced by a qualified technician.
- Do not cover the oven bottom with foil. Air circulation will be restricted.
- Never use gas ranges or ovens for heating purposes.
- Always have pot handles turned inward.
- Ensure children understand never to turn or play with the knobs on the front of the propane gas range.

**NOTES**



# SAHARA

## SECTION 8 ELECTRICAL SYSTEM - HOUSE

<b>INTRODUCTION • 211</b>	<b>BATTERY - HOW IT WORKS • 224</b>
<i>Shore Power • 211</i>	<i>Starting Battery • 224</i>
<i>Generator • 211</i>	<i>Deep Cycle Battery • 225</i>
<i>Inverter/Converter • 212</i>	<i>Battery Trays • 225</i>
<b>BATTERY CUT-OFF SWITCH • 212</b>	<i>Battery Maintenance • 226</i>
<b>SHORE POWER HOOK-UP • 212</b>	<i>Testing the Battery • 226</i>
<b>TRANSFER SWITCH • 215</b>	<i>Reasons Why Batteries Fail • 228</i>
<b>GENERATOR - 120 AC (LP-GAS) • 215</b>	<i>Battery Voltage &amp; Current • 229</i>
<b>GENERATOR - 120 AC DIESEL (Opt.) • 216</b>	<i>Battery Charge Time &amp; Consumption Rate • 230</i>
<i>Pre-start Checks • 216</i>	<i>Battery Specifications - House • 232</i>
<i>Starting the Generator • 217</i>	<b>INVERTER/CONVERTER • 233</b>
<i>Stopping the Generator • 217</i>	<i>Battery Charging • 233</i>
<i>Powering the Equipment • 218</i>	<i>Remote Panel • 234</i>
<i>Generator Fuel • 218</i>	<i>Battery State Indicator • 235</i>
<i>Resetting the Circuit Breaker • 219</i>	<i>Circuit Breakers • 235</i>
<i>Generator Exercise • 219</i>	<i>Stand-By Mode • 235</i>
<b>DISTRIBUTION PANEL - HOUSE • 220</b>	<i>Power Share • 235</i>
<i>Circuit Breakers • 220</i>	<i>Charge Cycles • 236</i>
<i>Fuses - 12 Volt DC • 221</i>	<i>Pass-through Relay • 236</i>
<b>GFCI BREAKERS &amp; OUTLETS • 222</b>	<i>Temperature Sensitive Charging • 236</i>
<i>Tools of the Trade • 223</i>	<i>Programming the Inverter • 237</i>
<i>Know When to Say No • 223</i>	<i>Equalize Charge • 237</i>
	<b>SOLAR PANEL - (Opt.) • 239</b>





## INTRODUCTION

The motorhome 120/240 Volt AC system can be operated from three different power sources: shore power, the on-board generator or the inverter/charger. Shore power is the most efficient and should be used whenever possible. The on board generator can be used when shore power is unavailable. The inverter/charger supplies silent AC power using the house batteries of the motorhome. This source has limited AC power output and should be used sparingly.

Two different sources supply the main AC circuit breaker panel with power: the 50 Amp shore power cord or the on board generator. The power source used is selected automatically by an automatic electrical switching device known as a transfer switch. The inverters supply AC power to the sub-panel.



**WARNING: The electrical system is engineered and tested for complete safety. Circuit breakers and fuses protect the electrical circuits from overloading. If you plan modifications or additions to the electrical system, we strongly recommend consulting your dealer for assistance to ensure continued integrity and safety of the electrical system. Please note that any modifications may void the warranty.**

The motorhome is equipped with a shore power cord. The electrical cord connects the motorhome to outside electrical services. Shore power service is the most efficient source of electrical power. Use this as the primary power source. The plug end of the shore power cord is 50 Amp 220 Volt. Many facilities are equipped with this power service. When this type of power service is not available electrical adapters will be required to allow a proper and safe connection to the electrical service supply.

### *Shore Power*



**NOTE: In instances when 50 Amp shore service is not available, care will have to be used when operating the appliances and using the outlets so the shore power service will not be overloaded.**

The generator can be selected for use when AC shore power is not available. The generators maximum amount of output power, measured in watts, is calculated at an elevation of 500 feet above sea level. This figure will decrease slightly with a higher altitude. Ambient temperature also effects total maximum output. The amount of AC electrical load applied to the generator determines fuel consumption.

### *Generator*

## Inverter/Converter

The inverter/charger can be used for silent AC power if shore power is not available, and using the generator is not going to be selected as a secondary power source. This device has limited AC power output, measured in watts. It operates only selected appliances and outlets. The inverter/charger is two components in one. First is as an auxiliary 120 Volt AC power source that uses 12 Volt DC house battery power to invert to 120 Volts AC. The second function of the inverter/charger is to use 120 Volts AC power, supplied from either shore power or the generator, and convert it to 12 Volts DC power to recharge the batteries. When dry camping, the inverter may be used to supply power to selected outlets.

## BATTERY CUT-OFF SWITCH

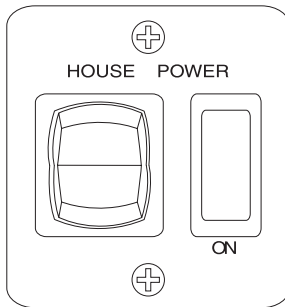

Battery Cut-off Switch.eps

The battery cut-off switch is located inside and next to the entry door. This switch controls the 12 Volt DC power to the domestic fuse panels. When the switch is ON power is supplied to all interior DC lighting and DC operated appliances. Some appliances will require both DC and AC power to operate, such as the roof air conditioner. This switch is helpful when dry camping and can be used to conserve house battery power. Refrigerator and inverter operation are unaffected by the operation of this switch. When turned off, this switch will not stop all parasitic loads.

## SHORE POWER HOOK-UP

The power requirement for the motorhome is 50 Amp 120/240 Volt AC single phase. The shore cord is stored in the roadside compartment. If 50 Amp shore power service is available, all that is necessary is connect the supplied shore power cord. If 50 Amp service is not available, electrical adapters will be required.



**CAUTION:** Avoid flash damage to the electrical system contacts. Before hooking up to shore power, starting the generator or using the inverter make sure all the appliances are off.



**WARNING:** Keep fingers away from metal contacts of the shore plug end. Avoid standing in water when making electrical connections. Serious electrical shock and personal injury can occur. To avoid the risk of an electrical shock, turn the circuit breaker off for the power supply outlet before making the shore power connection.

**Plugging in the Shore Cord:**

- Located in the roadside compartment is the shore power cord.
- Unscrew the deck plate and extend a sufficient amount of cable through the deck plate to reach the socket.
- Align cord end with socket terminals. Insert and rotate end clockwise  $\frac{1}{4}$  turn locking end into socket.
- If 50 Amp service is not available, install the proper electrical adapters to the cord.
- Always turn off the shore power breaker to the power supply outlet before connecting or disconnecting the shore cord. This will prevent an accidental shock and flashing of electrical contacts.
- Make the connection to the outlet and turn the shore power breaker on. The transfer switch should make an audible click.

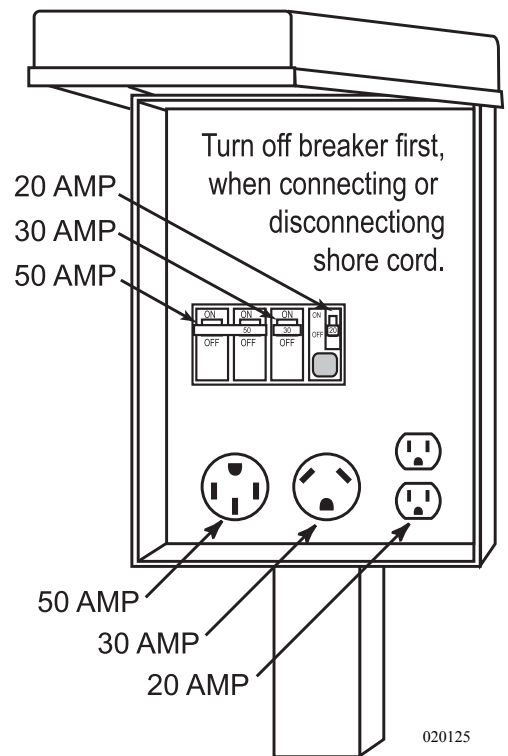

After connecting the motorhome to shore power, wait approximately one minute for the inverter/charger or converter to "stabilize" charging of the batteries before starting air conditioners or other large AC loads. In the instance 50 Amp service is not available, use caution not to overload the supplied shore service breaker. Operate appliances and outlets in sequence rather than all at the same time.

**Power Supply:**

Different amperage supplies vary greatly in the amount of available current.

- The continuous amount of current through a breaker or fuse is only 80% of its rated capacity.
- 50 Amp 220 Volt AC shore power service consists of two power supply conductors, a neutral and a safety ground. The 50 Amp breaker simultaneously limits each power supply conductor to no more than a short-term maximum of 50 Amps for each conductor. The 50 Amp 220 Volt service actually provides 80 continuous amps.
- Use care when hooked to anything less than 50 Amp shore service. Shore power service less than 50 Amps consists of one power supply conductor, a neutral and a safety ground. 30 Amp shore service is limited to 24 continuous amps. 20 Amp shore service is limited to 16 continuous amps.

**Electrical Adapters:**

There are many different electrical adapters available to suit a variety of needs. Only UL approved adapters should be used. The most common adapter is a 50-30 Amp adapter. The type of connector adapts the 50 Amp shore cord to a 30 Amp shore power outlet. Always install the adapter to the cord prior to making the connection to the outlet.

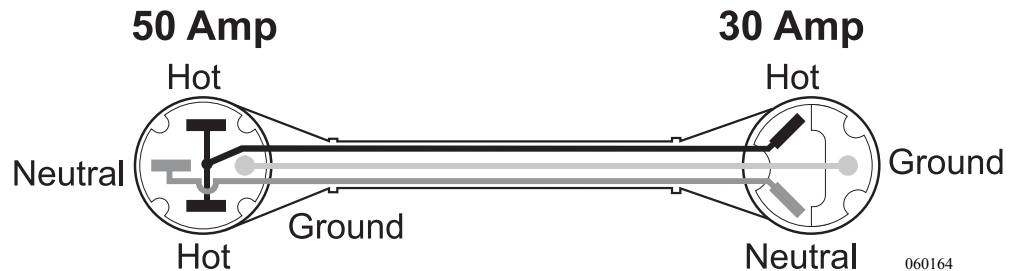

Another common adapter is a 30 to 15 Amp adapter. This type of connector adapts the 30 Amp shore cord to a 20 Amp shore power outlet.

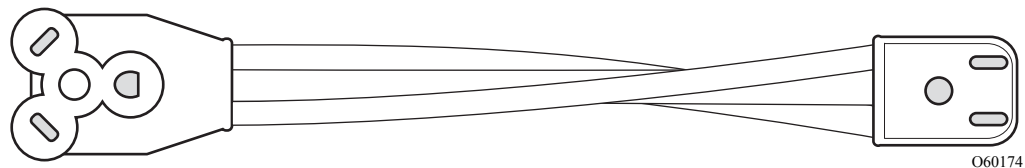

**CAUTION:** If shore power service is limited to 15 or 20 Amps, use of light duty extension cords and electrical adapters will create a voltage loss through the cord and at each electrical connection. Line voltage loss and the resistance at each electrical connection can be a hazardous combination. Damage to sensitive electronic equipment may result!



**CAUTION:** Avoid the risk of electrical shock or component damage by disconnecting from shore power during electrical storm activity. Use the inverter or start the generator if AC power is needed.



**NOTE:** Shown below are the three types of shore power outlets most commonly used.

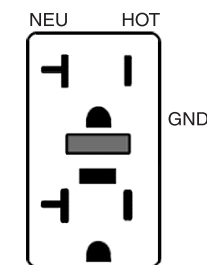

15-20 AMP  
120 VOLT

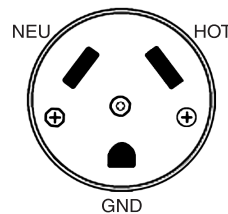

30 AMP  
120 VOLT

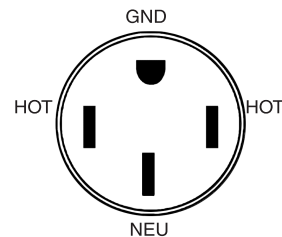

50 AMP  
220 VOLT

060121

The transfer switch automatically transfers AC power from the shore power cord or generator through the transfer switch to the 110/220 Volt AC breaker panel. When using the generator as the power source, the transfer switch has a time delay built into it before transferring power to the AC breaker panel. This allows the generator time to warm up before applying an AC load. When operating the generator while hooked to shore power, the transfer switch automatically selects generator power as priority over shore power.

## TRANSFER SWITCH

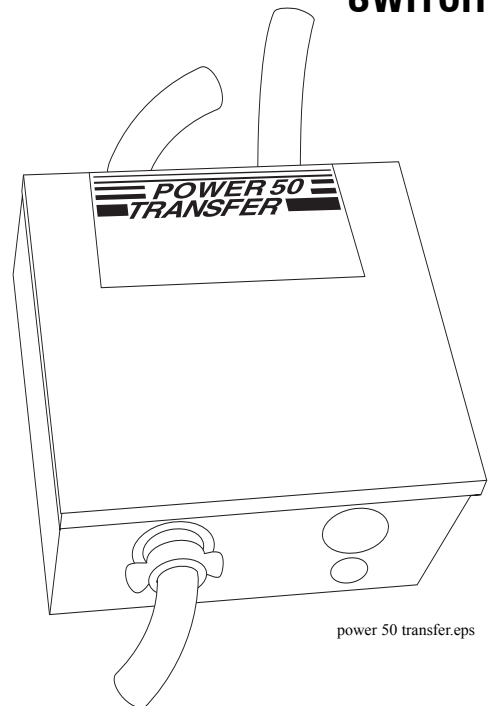

power 50 transfer.eps



**NOTE: The shore cord is NOT electrically connected to the generator. When the generator is operating, the electrical contacts of the shore cord are not electrically energized.**



**NOTE: To prevent damage to the transfer switch contacts do not have appliances on or AC loads plugged into outlets when hooking up to shore power or starting the generator. The transfer switch will begin to disengage at approximately 90 Volts AC. Operation at this voltage may damage the transfer switch, appliances or other items plugged into outlets. Start the generator and disconnect from shore service until the shore service supply voltage stabilizes.**

## GENERATOR - 120 AC (LP-GAS)

The standard Generator for the motorhome is a 6.5 kW LP generator. This generator provides 6,500 watts of power. This power is 120 AC Volts at 60-Hertz Frequency with 54.2 Amps of current.

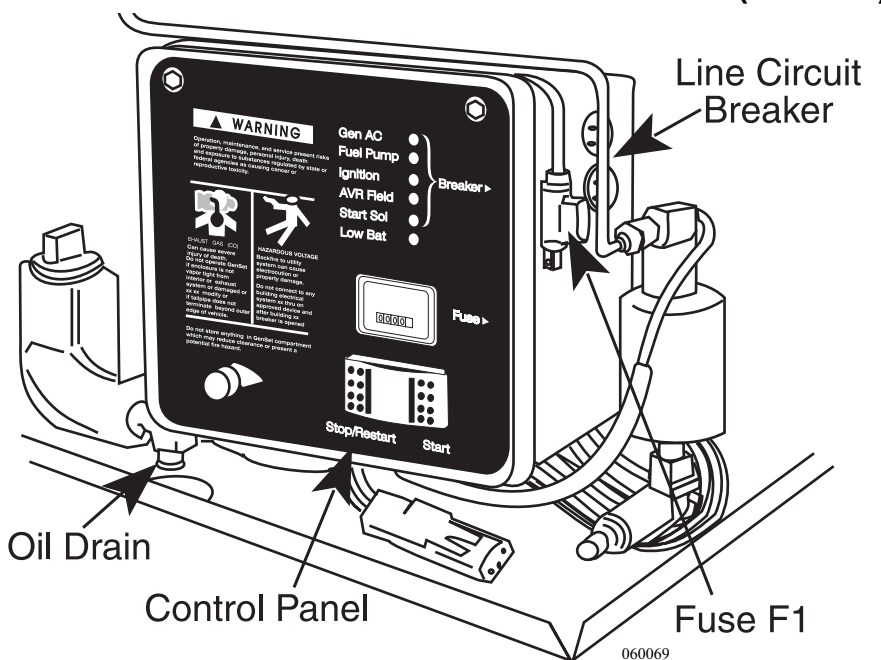

LP-Gas Generator - Standard

060069

**Fuel:**

Use clean, fresh HD-5 grade liquefied petroleum gas (LP-Gas) or equivalent product consisting of at least 90% propane. Commercial liquefied petroleum gas fuels may contain more than 2.5% butane which can result in poor fuel vaporization and poor engine starting in low ambient temperatures (below 32° F / 0° C). Satisfactory performance on low-pressure LP-Gas models requires that the LP-Gas vapor is supplied at a pressure within the range indicated in Specifications.



**WARNING: High LP-Gas supply pressure can cause gas leaks that can lead to fire and severe personal injury or death. Only trained and experienced personnel should adjust the LP-Gas supply pressure.**

**GENERATOR - 120 AC DIESEL (Optional)**

7.5 Kw

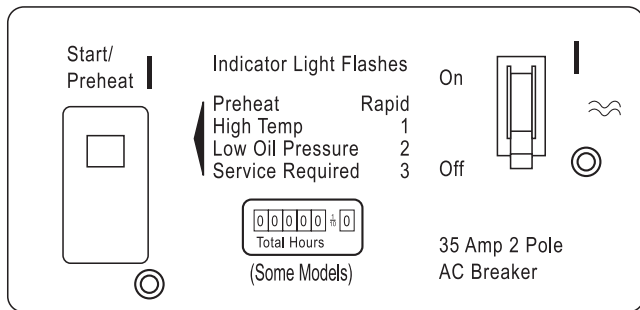

Generator Control Panel.

020159

The generator is located in the front compartment of the motorhome. The generator can be started from the following locations:

- The generator remote switch on the dash.
- The generator control panel located on the generator.

**Pre-start Checks**

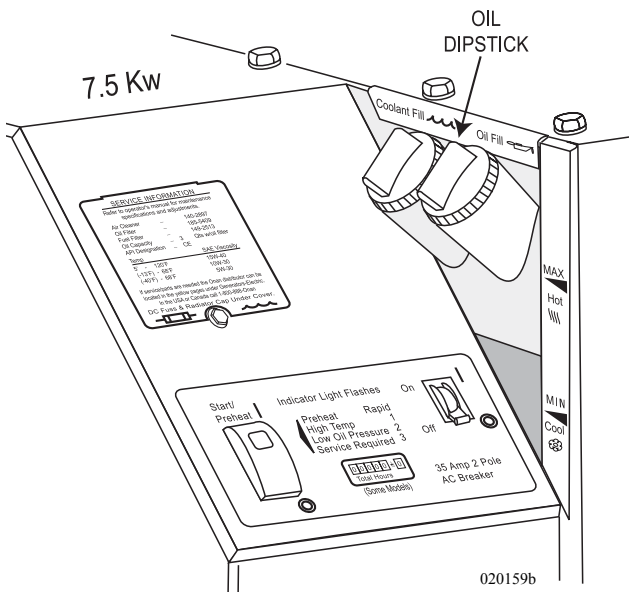

020159b

Prior to the first start of the day perform a general inspection including oil and coolant levels. Keep a maintenance log on number of hours in operation since the last service. Perform any service or maintenance that may be due.



**NOTE: Make sure the LP-Gas liquid valve is on for LP-Gas generators.**

**Before Starting the Generator:**

- People and animals must be clear of hazards of electrical shock and moving parts.
- All appliances and other large AC electrical loads must be off.



**Starting the Generator**

Push and hold control switch in **START** position until the generator starts. Release switch. On diesel models the control switch may flash up to 15 seconds, indicating engine preheat.



**NOTE: Diesel models may require priming. Hold control switch in the OFF position for one minute. Repeat if necessary. The diesel generator fuel pick-up tube is cut to approximately 1/4 tank so as not to run the main engine out of fuel.**



**WARNING: Excessive cranking can overheat and damage the starter motor. Do not crank the engine more than 30 seconds at any one time. Wait at least two minutes before resuming.**



**If the generator fails to start refer to the generator manufacturer's owner's manual.**



**WARNING: When the motorhome is parked, position the dash air conditioner vent control in the OFF position to prevent exhaust gases from entering the motorhome. The engine exhaust contains carbon monoxide, which is an odorless and colorless gas. Carbon monoxide is poisonous and can cause unconsciousness and/or death. Inspect the exhaust system thoroughly before starting the generator. Do not block the exhaust pipe or situate the motorhome where the exhaust may accumulate either outside, underneath, or inside the motorhome or any nearby vehicles. Operate the generator only when safe dispersion of exhaust can be assured. Monitor the outside conditions to be sure that the exhaust continues to disperse safely.**



**WARNING: When parking near high grass, be sure that the hot exhaust does not come into contact with the grass, it could be a fire hazard. Hot exhaust pipe or hot exhaust gases can ignite the grass.**

Turn off the appliances and disconnect other AC loads being used. Allow the generator to run unloaded for at least one minute before shutdown. This will allow the engine to cool. Push and hold the control switch in the **STOP** position until the generator stops. Release the switch.



**NOTE: Diesel models require only a momentary stop signal.**

**Stopping the Generator**

## Powering the Equipment

The AC output of the generator powers the motorhome air conditioners, the AC inverter/converter charger, all appliances and items plugged into the electrical outlets of the motorhome. The number of electrical appliances that can be operated at any given time depends upon how much power is available from the generator. If the generator is "overloaded" or a short circuit causes "over current," the generator will shut down or the circuit breaker will trip. If power consumption, in total, exceeds the generator power output, compensation for temperature and elevation may be necessary. Operate some appliances in sequence rather than all at the same time.



**NOTE: The generator may shut down when it is loaded nearly to full power and an air conditioner (or other large motor load) cycles on. For a brief moment during start up an electric motor can draw up to three times the rated power. For this reason, it may be necessary to operate some appliances in sequence when air conditioners or other large motor loads are on.**

It is important to remember that air density decreases as altitude increases, causing the generator engine power to decrease. Power decreases at approximately 3% of the rated power each 1,000 feet (305M) of increase in elevation above sea level. It may be necessary to operate fewer appliances at the same time when the camping location is at a higher elevation. For example: 7,500 watt generator at 5,000 ft. = 6,375 watts net. Temperature also affects maximum output power. For example: At 120° F. a 7,500 watt generator produces 6,000 watts net.



**REFERENCE: The generator may shut down for other reasons beside "overloads." A blink code may appear on the control switch. Refer to the manufacturer's manual to obtain an explanation of the codes.**

## Generator Fuel

When refueling there is always a possibility the fuel may be contaminated. Contamination of fuel affects the performance of the generator. Diesel fuel may contain water or a microbe growth (black slime). Propane, due to the refining process, may contain lightweight oil. Any contamination of fuel greatly reduces the total output of the generator and may cause erratic AC output.

AVERAGE FUEL CONSUMPTION	LP-GAS 6,300 WATTS (lbs./hr.)*	DIESEL 7,500 WATTS (gal./hr.)
No Load	2.6	.13
Half Load	4.5	.49
Full Load	7.3	.96

\* 4.5 lbs. = one liquid gallon of LP-Gas.



**NOTE: The motorhome manufacturer does not cover damage to the generator caused by fuel contamination, or to appliances due to erratic AC voltage.**

**Resetting the  
Circuit Breaker**

If a circuit breaker trips in the main AC breaker panel, or on the generator control panel, there may be a short circuit or too many loads.

 **NOTE: The generator will continue to run after a circuit breaker trips.**

If a circuit breaker trips, disconnect or turn off as many loads as possible. To reset the circuit breaker, switch the circuit breaker to **OFF**; then switch back to **ON** to reconnect the circuit. If the circuit breaker immediately trips, the electrical distribution system has a short or the circuit breaker is faulty. Call a qualified electrician. If the circuit breaker does not trip, reconnect a combination of loads that will not overload the generator or cause the circuit breaker to trip again. Remember to compensate for elevation and temperature changes when reconnecting loads.

 **NOTE: An appliance or load may have a short if it causes a circuit breaker to trip after reconnection. DO NOT continue to reset breaker. Have the problem corrected before resuming operation.**

7.5 Kw

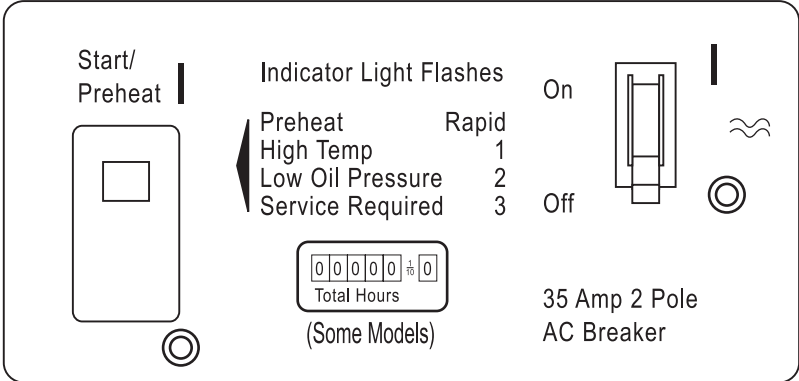

020159d

If use of the generator is infrequent, “exercise” the generator once a month by operating it at approximately half the maximum rated output for two hours. This “exercise” will help promote better starting, more reliable operation and longer engine life. This procedure drives off moisture, relubricates the internal engine parts and replaces the old stale fuel with a fresh supply. It also promotes removing oxides from the electrical switches and contacts.

**Generator Exercise**

 **NOTE: Avoid short run periods of the generator set. Run the generator set under a load for a minimum of one-half hour.**

## DISTRIBUTION PANEL - HOUSE

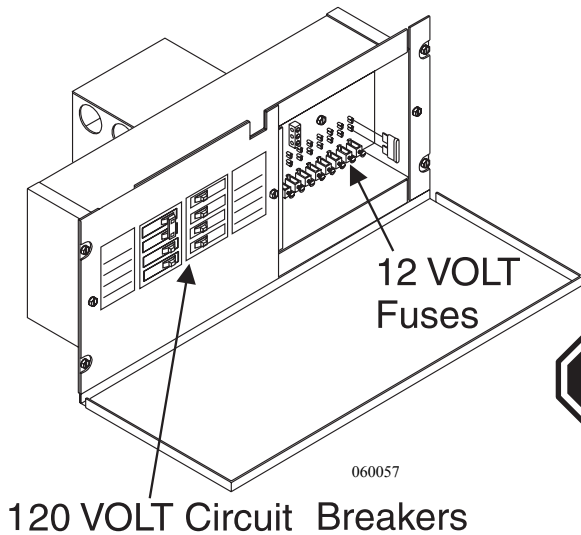

The AC/DC distribution panel is located in the bedroom or hallway. The 120 Volt circuit breakers receive power from the transfer switch, which is powered by either shore power or the on board generator. Power is introduced into the panel to the 50 Amp MAIN breaker first, followed by power being fed to the individual branch circuit breakers. The panel label describes the breaker layout and the item, outlet or appliance to which they pertain.

**WARNING: This panel contains high voltage which can cause serious injury or death. Before beginning any work or testing procedures involving the electric panels, or any of the branch circuits, be sure the motorhome is unplugged from shore power, the generator is not running and the inverter is in the OFF position. Certain testing procedures can require the AC power to be on. Only qualified personnel, or personnel with electrical backgrounds, should attempt any testing procedures.**

Branch circuit breakers supply AC power to the different items or "loads." An electrical load is any item or device that will use current when supplied with an electromotive force. Should a breaker "trip" from over current use, or a short circuit condition, the load to which the breaker is supplying the electromotive force should be reviewed or disconnected to determine the cause of the trip. If no cause is found, or not readily apparent, reset the breaker by toggling the breaker to the **OFF** position, then back to **ON**. Should the breaker trip again after the load is reapplied it may indicate a fault with that particular load.

Do not continue to reset breaker until the problem has been diagnosed and corrected.

---

### **Circuit Breakers**

Breaker current ratings are current set points in which the breaker is designed to operate. The internal configuration of the circuit breaker is designed to trip when excess current is drawn through the breaker. The breaker will heat up from the excess current causing the breaker to trip. The trip action of the circuit breaker can occur within milliseconds due to the speed at which electricity can travel. Breakers are designed to operate at a continuous load of 80% of the breaker's rated capacity. For example: A breaker with a 20 Amp rating will operate a continuous 16 Amp load. This design leaves a small amount of working capacity within the breaker. When an inductive load is applied, such as when an electric motor turns on, the motor starts to spin and current consumption may momentarily exceed the rated capacity of the breaker.

As the electric motor comes up to operating speed, the electric motor's current consumption will fall. The AC current load then falls back into the breaker's rated 80% set point. This electric principle should be kept in mind when using anything other than 50 Amp shore service and using appliances with electric motors, such as air conditioners. When using outlets, care should be considered when applying loads such as electric motors, heaters, coffee makers, toasters, hair dryers or other large current consuming loads. The current rating is usually stated on most electrical items. The current rating will either be rated in amps or watts. Current ratings stated on electrical items will change slightly with voltage fluctuations. As voltage increases current consumption decreases. As voltage decreases current consumption increases. This may explain why in some instances items operated at borderline voltage to current tolerances may seem fine in one location but problematic in another.



**NOTE: To calculate watts to amps simply divide the watt figure by the voltage of which the item operates from. For example: The electrical item is rated at 1,370 watts. Divide that by the operating voltage of 115 Volts which equals 11.913 Amps. Use this formula to calculate the amount of load to the available power supply.**

The 12 Volt DC fuses protect the low voltage electrical circuits. These fuses are a standard automotive type. When a fuse is "blown," the wire in middle of the plastic case will be burnt. A broken, bad or "blown" fuse must be replaced with a fuse of the same rating and type. Using a fuse with a different rating or type will defeat the circuit protection provided by that fuse and could result in damage to the motorhome's electrical system.

---

### **Fuses - 12 Volt DC**

The 12 Volt fuses, located in this distribution panel, service the interior house lighting, ventilation fans, monitor panel, furnace and water heater. Should a fuse blow it will be evident by the broken metal strip located in the center of the fuse. Replacement fuses should be of the same amperage. If a higher rated fuse is installed it can damage the wiring. Fuse current set points follow much of the same electrical principle as the 120 Volt AC breakers. Using 12 Volt DC as the electromotive force can make it more susceptible to outside influences, such as corrosion from weathering or oxidation.

The large variety of applications this voltage can be used in makes it a diet staple for most of the recreational vehicle and automotive industries. The danger from shocks with this voltage is minimized, but can still occur. A good example is when a magnetic field is generated, then collapses when the power supply is cut. The result is a discharge that can reach tens of thousands of volts for a short time period. Care should be used when working with this voltage as current values can be quite high, like in the case of a battery cables.

Shorting a battery cable to ground with a battery at a reasonable state of charge can result in a fire or serious personal injury from a burn.

## GFCI BREAKERS & OUTLETS

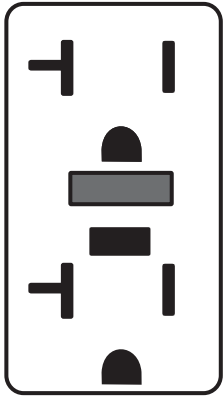

GFCI Outlet. 060072

A ground fault circuit interrupter “GFCI” can be found in two different types of applications. One type is incorporated in a breaker used in 120 Volt AC breaker panels, the other is incorporated in an outlet. The GFCI, whether it is a breaker or an outlet, offer two types of protection. One type of protection is from over-current or shorts. It also provides protection for persons against hazardous ground fault currents which can result in injury or death. Ground fault currents are currents that flow from the “HOT” or power terminal through a person to the ground. For example, touching a faulty appliance while standing on or making contact with an electrical ground such as a water fixture, bath tub or the earth. If the device has been properly installed it will offer protection against the type of shock that can result from faulty insulation, wet wiring from inside an appliance, or any device or equipment plugged in or wired to that circuit. The “ground fault” portion of the outlet or breaker uses sensitive electronics inside the outlet or breaker to detect a ground fault problem. The electronics monitor the normal current of power, flowing to the “hot” or black wire through the load (eg. a light bulb or appliance) and coming back on the “neutral” or white wire. If just a small amount of the current comes back on the safety ground wire the electronics will “trip” the breaker or outlet, stopping the flow of electricity. The amount of current it takes to trip the device from a ground fault varies slightly from the different outlet or breaker manufacturers (approximately 30 mils or less). Electrical shocks resulting from ground faults can be felt, but such a shock is considerably less than one without ground fault protection. People with heart conditions, or other conditions that make them susceptible to shock, can still be seriously injured. A GFCI outlet or breaker will not protect against shock from a normal current flow. For example, a shock from touching both metal prongs of an electrical cord or appliance while plugging it in.



**WARNING: If a breaker or outlet trips continually DO NOT continue to reset breaker or outlet until the problem has been identified and corrected.**



**NOTE: The ground fault outlet or breaker should be tested once a month to insure it is working properly. Use the “TEST” button on the outlet or breaker. It should trip with an audible “click.” The breaker or outlet will not trip if no AC power is present to the device. If power is present and the device will not “trip,” replace it before using that circuit.**



**NOTE: One mil is 1/1000 of one amp.**

**Tools of the Trade**

One of the most widely used tools for testing a 12 Volt problem is the test light. Test lights come in a host of varieties, such as a light bulb with a probe and ground clip, to the more elaborate electronic ones that measure a wide scale of voltages and perform a variety of functions. A VOM or Volt Ohm Meter is used to perform a multitude of tests. It is generally used when exact values are needed for evaluation. These meters come in an analog or digital format. Either of these two testing tools may be used, depending upon personal preference. If a 12 Volt light is not working, the test light may be better suited for this. In the case of a charging system problem the meter may be the tool of choice. In any situation the testing tool is an invaluable piece of equipment when it comes to determining an electrical problem.

If it is necessary to use testing tools, use precautions and consider three things. First, recognize when the problem is beyond your skill level. Nothing will create more problems than being armed with tools and going in an unknown direction. Good intentions can lead to major problems. The second item to consider is if something will cause more grief by being dealt with now than if it were left alone and repaired by a professional at a more convenient time. Items that seem as if they should only take a few minutes, may end up taking an entire day. The third item to consider is whether or not the current situation may be potentially dangerous if left to be repaired at a more convenient time.

**Know When to Say No**

**NOTE: Check all related fuses before assuming you have encountered an electrical problem or situation. Spare fuses should be kept on hand and can be purchased from auto parts stores. A fuse description label is on the distribution panel cover.**



**WARNING: If a fuse blows replace the fuse with same amperage rating and type. Installing higher amperage fuses can damage the wiring or the item the fuse is protecting, or may cause a fire. If the fuse repeatedly blows after replacing it do not continue to replace it. Have the problem diagnosed and corrected by a qualified technician.**

## **BATTERY - HOW IT WORKS**

Batteries come in different sizes, types, amp hours, voltages and chemistries. There are nearly as many descriptions of battery types and how they should be used as there are people willing to offer advice on them. Although it is not possible to cover batteries in their entirety, there are guidelines that can be followed to ensure that the batteries are well maintained.

The operation of the battery is based on a chemical reaction. The battery is a container of lead plates, insulators and a solution of distilled water and sulfuric acid. The solution, when mixed together, is known as “electrolyte.”

The 12 Volt battery is actually six batteries in one case. When charged, each cell has a voltage of 2.1 Volts. When six cells are hooked together this makes a 12.6 Volt battery (fully charged).

Electrons are stored on the negative plates. When a load (eg. a light bulb) is put between the positive and negative terminals, the electrons move from the negative plate to the positive plate through the “load” and then back to the ground terminal. At this time the sulfuric acid leaves the water and adheres onto the plates of the battery. The electrolyte solution keeps the electrons from flowing while the battery is in the “at rest” position.

Charging the battery moves the sulfuric acid back into solution with the distilled water. A battery left in a low or discharged state will cause the acid to “sulfate.” In attempting to recharge the battery, the acid has become hardened and no longer will leave the plates and enter into the liquid solution with the distilled water. The lowered acid to water ratio has a direct affect on the battery’s ability to release the stored electrons (power output) and the length of time it can perform (reserve capacity). Batteries left in a discharged condition will readily freeze. This can crack the case allowing the solution to spill, it can also warp the plates. The acid acts like an “antifreeze” for the battery. This is why batteries should not be left or stored in a “discharged” condition.

---

### **Starting Battery**

Starting batteries are designed for high output cranking power, but not for deep cycling like the house batteries are designed to do. Starting batteries will not last long in deep cycle application. The way they are rated should give a good indication of their intended use. “Cold Cranking Ampere” is a measurement of amperage output that can be sustained for 30 seconds. Starting batteries use thin plates to maximize the surface area of the battery. This allows a very high starting current but lets the plates warp when the battery is deep cycled (discharged).



**Deep Cycle Battery**

Deep cycle batteries are best suited for use with 12 Volt operated lights, appliances and inverters. Deep cycle batteries are designed to have a majority of their capacity used before being recharged. These are available in many sizes and types. The most common is a non-sealed, liquid electrolyte battery. The non-sealed types have battery caps. The caps should be removed periodically to check the level of electrolyte. When a cell is low, only distilled water should be added. Water consumption will vary depending on many factors: how far the batteries are depleted, how long the voltage is being applied to charge the batteries, how much voltage is used and how often this occurs.



**NOTE: Tap water contains minerals which can alter battery chemistry and ruin the battery. Use only distilled water when refilling the battery.**

The engine (chassis) and domestic (house) batteries are located in a curbside compartment. The slide-out battery trays are secured in place by a locking mechanism at the front of the trays. To slide the tray out, lift up on the handle and pull until the tray stops. To secure the battery tray, push it back in until the tray latches.

The battery tray slides will occasionally need to be lubricated. When performing maintenance to the batteries clean the old lubricant and dirt from the battery tray slide with solvent, brake cleaner or equivalent. Do not allow any of the cleaning solution or battery acid by-products to spatter onto the painted surfaces. Damage to the paint surface will result.

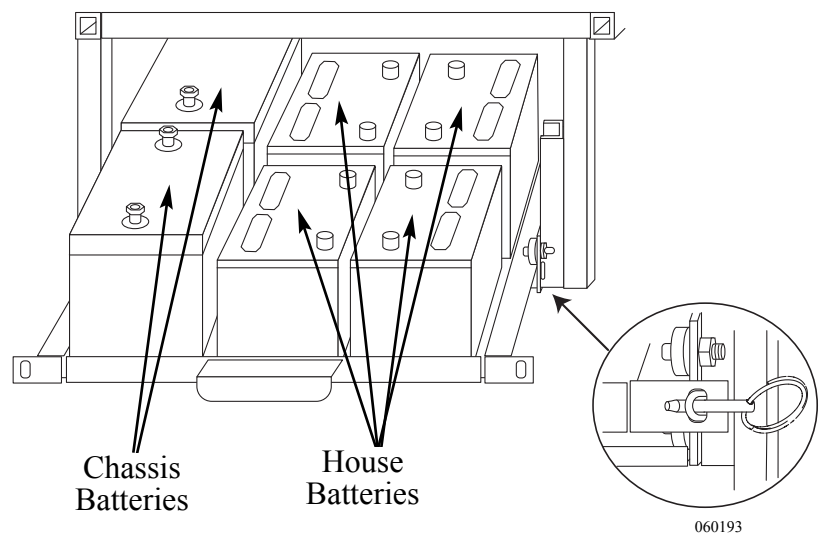
**Battery Trays**

Lubricate all moving parts of the battery tray slide with white lithium grease or *Kwikol* brand spray lubricant.



**NOTE: Driving without the tray secured can result in damages.**



**CAUTION: Many types of petroleum based products or battery by-products can damage the paint finish. Do not allow these types of chemicals to get on the paint finish. If the chemicals do get on the painted surfaces immediately rinse the surface using plenty of water with a mild automotive detergent.**

## Battery Maintenance

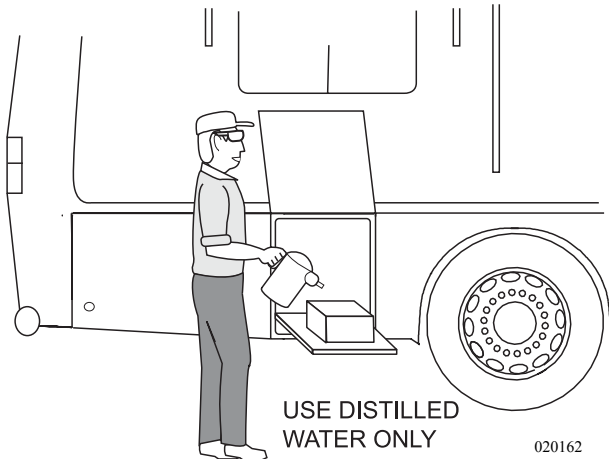

*Wear safety glasses when servicing the battery.*

At a minimum, the battery electrolyte level should be checked at least once a month. Check the level sooner if the battery is frequently used. The level should be above the top of the plates, but not overfull. Most batteries have a plastic cup or well. The electrolyte level should be approximately 3/8" below the well to allow room for expansion while the battery is being charged. Over-filling the battery will allow the electrolyte solution to boil or gas out of the battery cap. Remember to use only distilled water to refill the battery. A battery with a low electrolyte level will boil the water out rapidly once the plates have been exposed to air. This process may take only a matter of hours. If this has happened the battery is more than likely damaged.

After checking the battery's electrolyte levels it is also a good idea to check the battery connections for tightness and corrosion. If any corrosion is found disconnect the cables (make sure to mark their locations) and carefully clean them with a mild solution of baking soda and water. There are also aerosol products available that will work. This will neutralize any acid that may be present. Do not allow the solution to enter the battery as this will damage the electrolyte balance. Use water to rinse the top of the battery and surrounding area when done. Carefully hook the cables back to the battery. Coat the terminals with petroleum jelly or an anti-corrosion grease.

The battery cable to battery terminal connections should be metal to metal. Periodically check the batteries for corrosion. Look for cracks and check the vent plugs. Replace them if they are cracked or missing. Keep the top of the batteries clean. The accumulation of electrolyte and dirt may permit small amounts of current to flow between the terminals, which can drain the battery.



**WARNING: Liquid lead acid batteries produce hydrogen gas while being charged. This is highly explosive. Do not smoke around batteries. Extinguish all flames in the area. The hydrogen gas may explode resulting in fire, personal injury, property damage or death.**

## Testing the Battery

There are several ways in which a battery can be tested and monitored. The motorhome uses a monitor panel which shows the status of the house batteries at a quick glance. Pressing and holding the test button, the power level will be displayed on the battery scale.

A more efficient way of testing the batteries is to check the electrolyte solution. The only way to test a battery's electrolyte solution is with a hydrometer. Hydrometers can be purchased from most auto parts stores.

Many styles are available, from types with cylinder graduation (shown here) to types with floating balls. The hydrometer tests the battery's electrolyte solution which is measured in specific gravity. Distilled water has a specific gravity assigned gravity of 1,000. The hydrometer is calibrated to this mark. Pure sulfuric acid has a specific gravity reading of 1,840. The acid is 1.84 times heavier than water. The electrolyte solution is about 64% water to 36% acid (fully charged battery). Hydrometers with cylinder graduation are graphed and the exact state of specific gravity can be determined.

Temperature and recent battery activity (charging or discharging) affect the hydrometer readings. It is best to check the battery when it has been "at rest" for at least three hours, although readings taken at other times will give a "ballpark" figure. When using the hydrometer, draw the electrolyte solution up into the tube. Allow the hydrometer to attain the same temperature as the electrolyte solution. Note the reading for that cell. Complete the same test for the rest of the cells on that battery bank.

The hydrometer is calibrated at 80° F. Temperature affects the hydrometer readings. The higher the electrolyte temperature, the higher the specific gravity reading. The lower the temperature, the lower the specific gravity reading. Add or subtract four points for each 10° variance from the 80° F chart. Readings between cells should not vary more than 50 points.

If one cell in a particular battery bank being tested is at a 50% state of charge while the others are indicating a full charge, charge only that battery to see if the low cell will come up. At the same time, do not over charge the "healthy" cells.

If the low cell does not come up after charging, this battery can damage the rest of the battery bank and should be replaced. An accurate digital volt meter + - .5% will also give an indicator of the battery's state of charge.

Another test that can be performed is to place a specific load on the battery for a predetermined length of time equal to that particular battery's rating. This machine is usually an adjustable carbon pile that can vary the load being applied to the battery(s) while monitoring voltage to see if they will perform to their specific rated capacities.



**NOTE: See the chart for temperature compensation. Liquid levels should be even between the cells of the battery being tested as it will affect the accuracy of the test.**



**WARNING: Sulfuric acid in the batteries can cause severe injury or death. Sulfuric acid can cause permanent damage to eyes, burn skin and eat holes in clothing. Always wear splash-proof safety goggles when working around the battery. If the battery electrolyte is splashed in the eyes, or on skin, immediately flush the affected area for 15 minutes with large quantities of clean water. In case of eye contact, seek immediate medical aid. Never add acid to a battery once the battery has been placed in service. Doing so may result in hazardous splattering of electrolyte.**

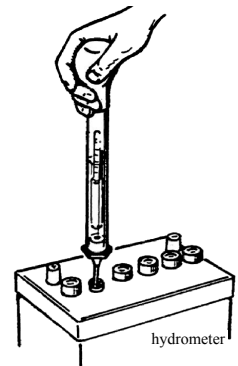

Hydrometer (Cylinder Type).

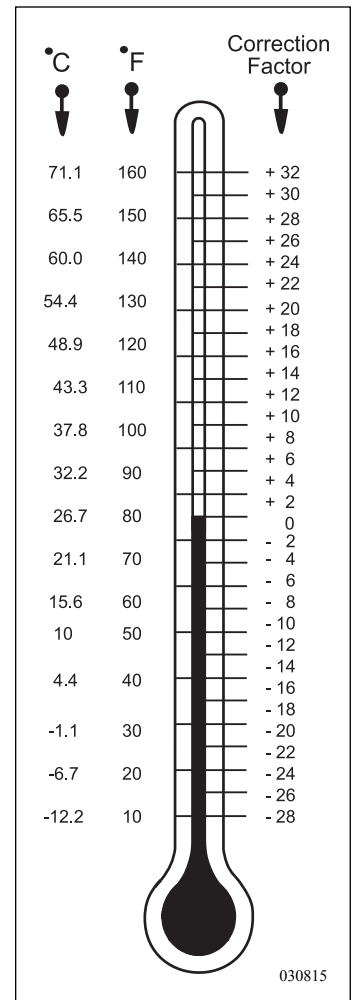

Temperature Correction Chart.

## **Reasons Why Batteries Fail**

### **1. Physical Condition:**

Active material flakes off the plates and falls to the bottom of the cell.

This is normal, but sediment accumulation under the plates can short out a cell. The plate separators fail to insulate positive and negative plates in a cell and the cell becomes shorted, ruining the battery.

### **2. Insufficient Electrolyte:**

This allows exposed portions of the plates to sulfate rapidly. This reduces the battery's ability to accept a charge and the battery capacity is reduced. Accelerated erosion of the lower portions of the plates occur from higher than normal acid content due to water loss. Only the water evaporates, not the acid. The battery also has a higher internal resistance when low on water. Add only distilled water. Fill each cell to the bottom of the vent well when the battery is warm. Filling a very cold battery with water to the bottom of the vent well will cause overspill when the battery warms up and the plates expand. A Battery Formula For Failure: the battery has a higher internal resistance when low on water, therefore: *high resistance = more heat = shorter battery life!*

### **3. Sulfation:**

When a battery remains discharged for too long the accumulated lead sulfate in the plate material solidifies and cannot reenter the electrolyte. When a battery is left in a discharged state the lead sulfate will crystallize. Charging the battery does not move the crystallized lead sulfate off the battery plate. The battery is damaged.

### **4. Overheating:**

The chemical reaction inside of the battery is increased when the battery temperature rises above 125° F. This increases the corrosion of the plates and reduces the battery life. When overheated, the battery plates tend to buckle and destroy the structural integrity of the battery.

### **5. Freezing:**

When the electrolyte freezes, ice formed dislodges the active material from the plates. The battery case may crack and the electrolyte will leak out when thawed. It is especially important to keep a battery at full charge in cold weather to prevent freezing. The high specific gravity of a fully charged battery does not freeze as easily. Never attempt to charge a frozen battery. Warm it up first.

### **6. Corrosion:**

Corrosion from spilled or splashed electrolyte form deposits that can conduct electricity and can cause battery drain. Clean off all corrosion, especially around the battery terminals and on the top of the battery. Prevent accumulation by coating the terminals and the exposed metal cable connectors with high temperature grease.

## 7. Overcharging:

Overcharging rapidly converts water to gas and decreases the electrolyte's water content as the water evaporates. The electrolyte level drops and becomes more acid in content. This subjects the plates to a higher concentration of sulfuric acid and results in early battery failure.



**NOTE: Any time more than one or two ounces of distilled water is added per-cell per-thousand miles, check the motorhome charging system for overcharging. Prolonged overcharging generates excessive heat inside the battery, which buckles the plates and destroys the battery. It is a fact that over 50% of battery failures are caused by overcharging.**

Why does the voltage on a discharged battery measure the same as a fully charged battery until the loads are applied? The simple answer to this might go as follows: A battery creates electrical power by converting energy from a chemical reaction into electrical energy. As this reaction slows down the battery voltage will drop. In a lead acid battery the electrolyte conductivity (how well electrical current can flow through it) changes. The same current may be available but the rate of the reaction decreases, causing a voltage drop.

Another way of looking at this is to use the analogy of a water pump (a battery is an electric pump). The pressure in psi (pounds per square inch) that a pump delivers is like a battery's voltage. The volume of water in GPM (gallons per minute) is like the electrical current. Look at a 12 psi pump with no loads (the pump is running but the outflow valve is turned off). The pump will run and the internal pressure of the pump will build up to some point higher than 12 psi. When the valve is opened, and the water is free to flow into the loads, the pressure will drop to the rated output pressure of 12 psi, but only if the load is not too big. If the pump is designed to maintain 12 psi at 15 GPM, and a load demanding 20 GPM is connected, the pump will not be able to keep up and the pressure will get sucked down to a lower psi. If the load is reduced or removed the pump will catch up and return to its rated 12 psi pressure. If the pump has an infinite source of water, such as a lake or the water utility (this is like the grid, no battery), the pump will never run out of pressure. If the pump never runs out of pressure, and is operated at or below its 15 GPM level, it will hold 12 psi. However, a pump that is connected to a water tank with a finite capacity will start to lose the ability to hold pressure as the level of water in the tank drops. Think of siphoning water from a bucket. As the level of the water drops, the volume of water exiting the siphon slows down.

## Battery Voltage & Current

When the tank is full it is capable of feeding more “pressure” to the pump inlet due to gravity, and the pump always has enough water available to maintain its rated pressure and volume. However, if the water tank gets low the pump will not have enough water volume coming in to maintain 12 psi at 15 GPM. If the loads are removed from the pump by closing the valve on the outflow, even with low pressure in the tank the pump will eventually pressure up to 12 psi. It will just take it longer to get there. When the valve is opened the pump will sustain 12 psi for a brief period, but since the tank is no longer feeding the pump as fast as needed the pressure will eventually drop. This analogy can be restated by replacing the pump with a battery, pressure with voltage, volume with amps, outflow valve with a switch, water with electricity and the water tank with the battery electrolyte.

The level of the tank could be thought of as the rate of the reaction occurring in the electrolyte. When the battery is fully charged the electrolyte has an excess of reactions taking place to feed the battery terminals. This tapers off with time as the electrolyte is spent, so maintaining voltage becomes possible. With no loads the discharged electrolyte will be capable of producing close to the rated voltage, but only after a period of time has elapsed for enough of a reaction to take place to bring the voltage back up. Hopefully, this explanation will clarify why a battery measured at rest can indicate close to its rated voltage but will not run a load.

---

### ***Battery Charge Time & Consumption Rate***

#### **Calculating Run Times:**

Calculating run time figures when operating 120 Volt AC electrical items with an inverter can be exponential. This is due to battery characteristics. Flow characteristics of electrons vary with different battery types and chemical compositions. Deep cycle batteries are generally designed to slowly release a majority of their charge capacity. Deep cycle batteries are rated in amp hours (Ahrs) with the discharge occurring over an extended period of time before the battery is charged. Engine starting batteries are designed to quickly release large amounts of current for short durations, without depleting battery reserves. Commercial type batteries bridge the gap of deep cycle and engine batteries. Commercial batteries release medium amounts of current over a longer period of time but they are not designed to cycle their charge capacity.

The working range of a deep cycle battery is between 50 and 100% state of charge (SOC). Deep cycle batteries should not be cycled below 50% state of charge. Discharging a deep cycle battery below 50% state of charge shortens the life of the battery. Deep cycle batteries use an amp hour rating which is usually calculated over a 20 hour discharge interval. For example: A deep cycle battery with a rated capacity of 100 Ahrs. is designed to release current at the rate of 5 Amps per hour. Multiply a 5 Amp load over a 20 hour discharge period equals the rated 100 Ahr. capacity. These discharge figures are calculated

with the battery starting at 100% state of charge with the battery at 80° F when the discharge cycle begins. However, increasing the discharge load applied to the battery from five amps to ten amps on a 100 Ahr battery does not yield 10 hours of discharge time. This is due to the internal reactions which occur when a battery is discharging. Actual discharge time for a 10 Amp load may be closer to eight hours of discharge time. Increasing the load applied to the battery to 20 Amps will not yield five hours discharge time but may be less than three hours. It might be understood as a point of diminishing return.

Calculating applied loads to an inverter to approximate run time from the battery amp hours available is not an equal trade up when voltage is inverted and amperage is calculated. When the inverter is used to operate an AC load it uses approximately ten times the DC current needed from the battery when inverting 12 Volts to operate the 120 Volt item. There is also a small efficiency loss of about 10% when inverting. For example: When using the inverter to operate an AC electrical item, which has a current draw rating of 2 Amps, the inverter will use over 20 Amps DC power from the batteries.

#### **Determining Current Consumption:**

First determine the amount of current used by an AC item. For example: The television is rated at 200 watts at 120 Volts. Calculate watts to amps. Divide 200 watts by the operating voltage of 120, this equals 1.6 Amps. Multiply 1.6 Amps AC current by a factor of ten the inverter will use, this equals 16 Amps DC battery current. Add the revised 10% efficiency loss figure, this calculates to a total of 17.6 Amps DC. If the battery bank capacity is rated at 500 Ahrs., actual elapsed time to the suggested 50% state of charge would net viewing time for the television at approximately 13 hours in ideal conditions.

The run time figure will vary greatly with the actual state of charge of the battery bank when the discharge process begins. Ambient temperature, combined with other working loads, such as lights and parasitic loads applied to batteries, affect run times. Calculating the exact run time is not precise due to all the variables and equations involved; however, an approximate time figure can be obtained. Proper battery maintenance and charge cycles affect battery performance. Observe the battery condition with hydrometer and voltage readings. Use only distilled water when filling batteries. To achieve the highest quality of battery performance and longevity keep batteries in their proper operating range.

**Battery Specifications - House**

<b>BATTERY</b>	<b>AH (20HR)</b>	<b>CCA</b>	<b>RC (25A) MINUTES</b>
Chassis 12 Volt Chassis 31P-MHD (2 each)	240	750	450
6 Volt Domestic U2200 (4 each)	450*	**	447

*\*Total battery bank capacity. \*\*Battery connections are made in a Series/Parallel connection. Domestic batteries are not rated in Cold Cranking Amps (CCA).*

<b>Battery State of Charge vs Voltage/Specific Gravity</b>			
<b>VOLTAGE</b>	<b>SPECIFIC GRAVITY</b>	<b>STATE OF CHARGE</b>	<b>DEPTH OF DISCHARGE</b>
<b>12.66</b>	<b>1.265</b>	<b>100%</b>	<b>0%</b>
<b>12.45</b>	<b>1.225</b>	<b>75%</b>	<b>25%</b>
<b>12.25</b>	<b>1.190</b>	<b>50%</b>	<b>50%</b>
<b>12.05</b>	<b>1.145</b>	<b>25%</b>	<b>75%</b>
<b>11.90</b>	<b>1.100</b>	<b>0%</b>	<b>100%</b>

*Battery Voltage: Fully charged with battery at rest for one hour.*

*Battery Charge Voltage chart*

<b>CUMMINS ENGINE COLD CRANKING AMPS REQUIREMENTS</b>			
<b>ISC</b>	<b>1250</b>	<b>CCA</b>	<b>12 VOLTS</b>



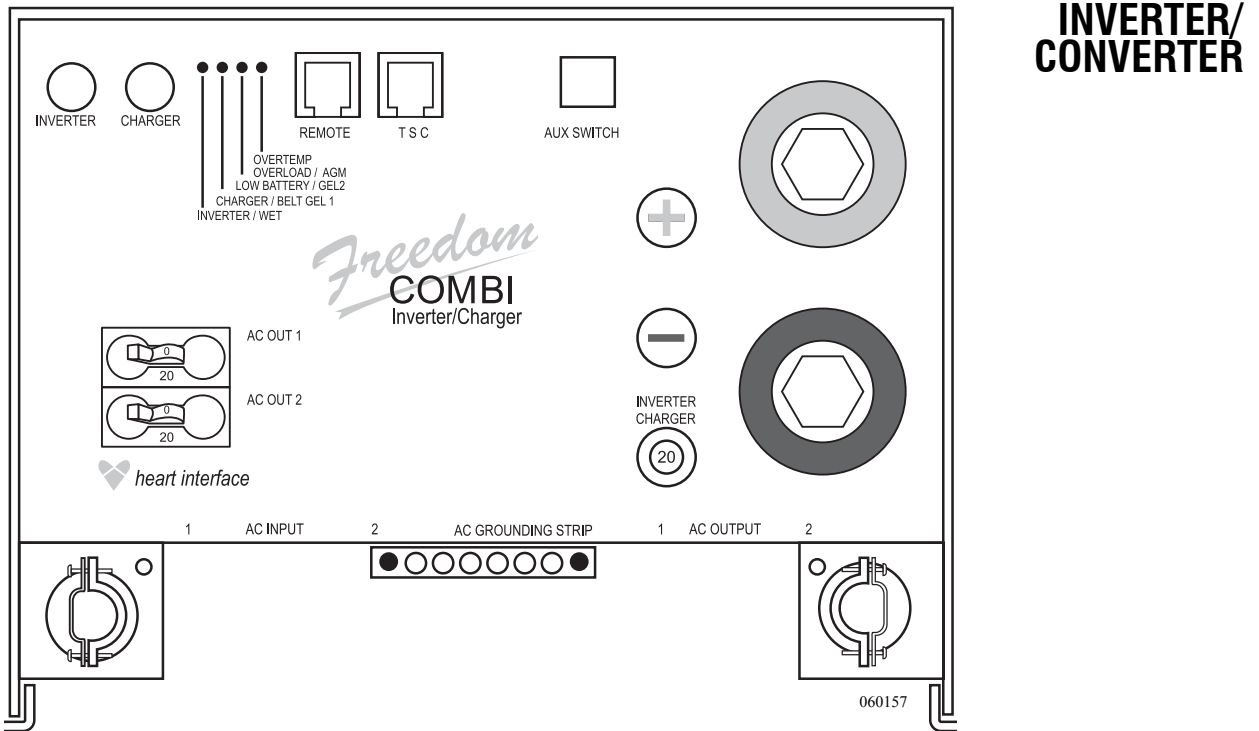

The inverter performs two functions, first it changes DC battery power to AC electrical power. Second, it charges the batteries when hooked to shore power or operating from the generator. Use the inverter to supply AC power when shore power is not available and the generator is not going to be used as a secondary AC power source. The inverter supplies AC power to most receptacles, the television and microwave. It is important to remember that using the inverter quickly consumes house battery power. Turn off the inverter when not in use to conserve house battery power. The remote control is used to change the variable settings.

#### To turn Inverter On:

- Press the switch marked **INVERT** on the remote panel.

The inverter will automatically begin charging when AC power is supplied from shore service or the generator. The charger uses a three-stage cycle to charge the batteries. If desired the charger may be turned off.

### **Battery Charging**

#### To turn the charger OFF or back ON:

- Press the switch marked “**CHARGE**” on the remote panel.



**REFERENCE: Complete detailed instructions and guidance can be found in the Owner's Information File Box. Please refer to the information booklet provided from the manufacturer.**

## Remote Panel

The remote panel monitors the inverter status and is used to change variable settings. The panel uses LED lights to monitor values when hooked to shore power, inverting or in the set-up mode.

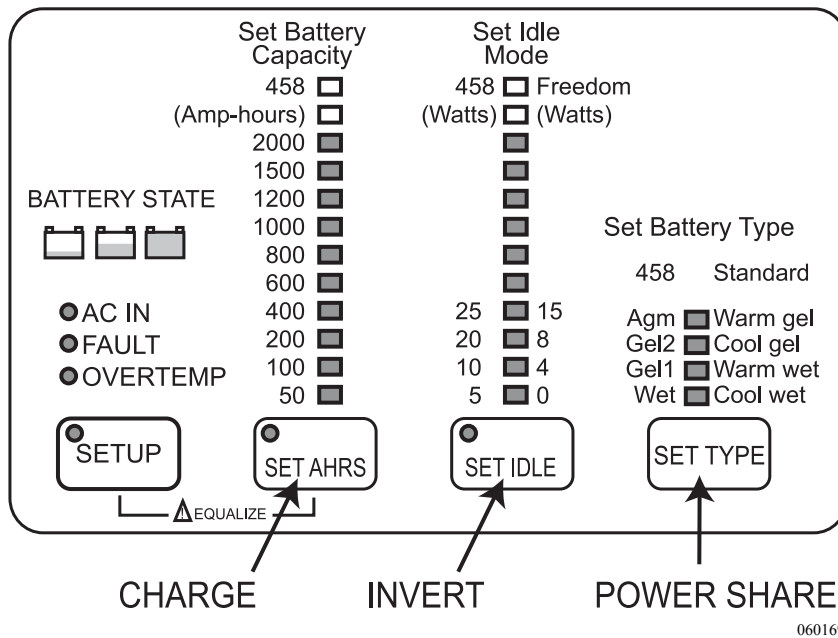

### LED indications when hooked to Shore Power:

- DC Volts represents DC output voltage at the inverter.
- DC Amps represents the amount of DC charge current.

### LED indications when Inverting:

- DC Volts represents DC battery voltage at the inverter.
- DC Amps represents the amount of DC discharge current.

### LED indications when in Set-up Mode: (Press and hold SET-UP for five seconds):

- DC Volts represents the amount of Amp Hours of the battery bank.
- DC Amps represents the amount of load (measured in watts) needed to activate the inverter.
- Incoming AC Breaker Amps represent battery type and operating temperature.

The battery state indicator performs two functions. When not hooked to shore power the Battery State indicator displays the approximate state of charge of the house batteries. When connected to shore power or operating from the generator, the lamps indicate what part of the charge cycle the inverter is in.

## **Battery State Indicator**

- **Red = Bulk Charge**
- **Yellow = Accept Charge**
- **Green = Float Charge**

---

### **Battery Charger Circuit Breaker:**

## **Circuit Breakers**

The circuit breaker for the charger is located on the front of the inverter. The breaker is a re-settable breaker in case an over current or short circuit condition occurs within the Battery Charger circuitry.

### **AC Out Circuit Breakers:**

Two branch circuit breakers are located on the front of the inverter. One of the branch circuit breakers supplies AC power to various receptacles. The other breaker supplies AC power to the microwave.

The inverter may be placed in "STAND-BY" when hooked to shore power or operating from the generator. If AC power discontinues, the inverter activates automatically. When AC power resumes, the inverter will go back to **STAND-BY** mode. **STAND-BY** mode is indicated by the **INVERT** status light flashing once every two seconds when hooked to shore power or operating from the generator.

## **Stand-By Mode**

### **To enable or disable this feature:**

- Press the **INVERT** button.



**NOTE: Remember to disable stand-by mode when not in use. It may run down the house batteries.**

Setting the Power Share amps can limit the amount of AC power available to the internal charger. Battery charger draw can exceed 20 AC Amps. When hooked to anything less than 50 Amp service it may be necessary, depending on other AC loads, to adjust the Power Share amps to avoid overloading the shore power breaker.

## **Power Share**



**NOTE: Limiting the amount of useable current for the charger increases the amount of time necessary to charge the batteries.**

## **Charge Cycles**

The time it takes to fully charge the batteries varies greatly. It can take several hours or even days, depending on the inverter's settings and state of charge of the batteries. The charge cycle is done in three steps:

- **First step is "BULK" charge.**

The "bulk" charge will bring the DC voltage up high, initially between 14.2-14.5 Volts DC, depending on conditions. The length of the bulk charge cycle depends on the condition of the battery, loads and other factors. When the battery voltage attains 14.2-14.5 Volts DC, the charger begins the next cycle.

- **Second step is the "ACCEPT" cycle.**

The voltage in this cycle is the same as the bulk charge cycle 14.2-14.5 Volts DC. The length of the absorb cycle will vary with state of charge of the batteries.

- **Final step is the "FLOAT" charge cycle.**

Approximately 80% of the charging has been completed at this time. The float charge voltage is generally around 13.3-13.7 Volts DC. The last 20% of the charge cycle of the batteries typically takes the most amount of time. The charging cycle is initiated each time the inverter is disconnected or reconnected to AC power. Repeated charging cycles in succession can lead to boiling of the batteries.

---

## **Pass-through Relay**

Incorporated in the inverter is a double pole "pass-through" relay that trips when AC power is supplied to the input terminals. This relay transfers AC power through the inverter to the two circuit breakers located on the front of the inverter. The two breakers supply AC power to various outlets and the microwave. When AC power is supplied to the inverter, the internal battery charger will "ramp up" battery charge voltage. A 20 second time delay allows charge stabilization before pass through AC power is supplied to the breakers.

---

## **Temperature Sensitive Charging**

The inverter uses a battery temperature sensor to adjust charge voltage. When the battery temperature rises the sensor sends this information to the inverter to decrease charge voltage. Voltage compensation with temperature variation is necessary to keep charge voltage at optimum values. The sensor is secured to the terminal of the battery.

Battery Capacity and Idle Mode are adjustable. The program mode must be entered to change a setting.

**To Enter the Programming Mode:**

- Press and hold the **SETUP** button for five seconds. LED lamps will change from **green** to **red**.
- If a setting change does not occur within five seconds, the remote returns to the user menu.
- Use the Remote Owner's Manual to cross-reference the LED lights to their respective indication.

**Idle Mode:**

Setting the **IDLE** mode controls the threshold (in watts) that turns the inverter on from search mode. The adjustment range is 5 to 100 watts. The factory setting is five watts. Press the **INVERT** button to change the settings.

**Battery Capacity:**

Setting the proper battery capacity tailors the internal charger to optimum values. The Factory setting is 400. Press the **CHARGE** button to change the settings.

---

Batteries can sulfate over time. When sulfating occurs some of the sulfuric acid has adhered to the lead plates of the battery and does not enter the electrolyte solution though normal battery charging. A battery with a low concentration of acid in the electrolyte will effect the battery's performance. Sulfation can occur when a battery is stored in a discharged condition or when a battery is continually cycled below a 50% state of charge. An indication a battery has sulfated is when the inverter is in float charge and the hydrometer reading has stabilized below a full state of charge (approximately 1260).

**Equalize Charge**

An equalize charge cycle may promote the acid to leave the lead plate and enter the electrolyte solution. This is done by charging the battery at a slightly higher than normal voltage for a short duration. The equalization cycle will charge the batteries at approximately 15.5 Volts for eight hours. To maximize the results from equalize charging initiate the equalize cycle after the inverter has entered float charge.

Only liquid lead acid or absorb glass matte (AGM) type batteries should be equalize charged. Other battery types can be damaged if equalize charged. Monitor the electrolyte solution closely when equalizing a liquid lead acid battery. A battery's "healthy" cell(s) can be damaged if overcharged. High DC charge voltages can also damage voltage sensitive electronic equipment.



**NOTE: Several precautions should be used when performing an equalize charge.**

**Precautions to Take When Performing an Equalize Charge:**

- Only equalize charge batteries with the motorhome in a well-ventilated area, preferably outdoors. Liquid lead acid batteries produce explosive hydrogen gas when charging. Extinguish all flames and eliminate other sources of ignition.
- Secure the battery compartment door in the open position.
- Remove the battery caps during the equalize charge cycle.
- A liquid lead acid battery will consume water when equalize charged. Fill battery cells with distilled water before beginning an equalize charge cycle. Do not overfill the cells. Overfilled battery cells will spatter excess electrolyte.
- Protect all painted surfaces from any electrolyte solution that may spatter during equalize charging. If the electrolyte solution spatters on the exterior painted surface rinse immediately using large quantities of water.
- Turn **OFF** the battery cut-off switch located at the entry door.
- Observing polarity, disconnect the 12 Volt DC supply from the refrigerator. Access supply leads through the outside refrigerator compartment. Tape the positive lead to prevent a short circuit.
- Avoid operating any electrical equipment while in the equalize charge cycle.

**To Equalize Charge:**

- Press and hold the **SETUP** button on the remote for five seconds.
- After the LED lights change from green to red press and hold the **SETUP** and **CHARGE** buttons simultaneously.
- The Battery State indicator lamps flashing sequentially indicate equalize charge. The inverter will run an equalize charge cycle for about eight hours.

**To Exit Equalize Charge:**

- The equalize charge cycle may be discontinued at any time during the charge cycle. Press the **CHARGE** button.
- Allow the batteries to cool for approximately three hours. Check the electrolyte solution with a hydrometer. Avoid overcharging the battery resulting in damage to the healthy cells.
- Add distilled water if necessary. Install battery caps. Use large quantities of water to rinse the entire battery compartment and surrounding area.
- Observing polarity, hook the 12 Volt DC supply leads to the back of the refrigerator. Do not reverse polarity. Damage to the refrigerator circuit board can result.



**CAUTION: Never attempt to charge or equalize charge a frozen battery.**



**WARNING: Liquid lead acid batteries produce highly explosive hydrogen gas when being charged. Extinguish all flames and other sources of ignition. Never smoke around batteries. Danger of explosion, fire, property damage, serious personal injury or death can result!**

---

The system consists of one roof-mounted solar panel and a charge controller located under the bed on the Isolator Panel. The solar panel is a laser-grooved, buried-grid panel that is capable of delivering about two or three amps of charge per hour in full sunlight (usually between 9:30 a.m. and 2:30 p.m.). Extensive testing has shown that the solar panel delivers enough power to offset the normal day-to-day drain on batteries caused by various parasitic electrical loads. These parasitic loads are usually associated with transmission memories, natural self-discharge of batteries and other like items. This means that the solar panel is only intended to cover these parasitic loads while dry camping.

**SOLAR PANEL  
(Optional)**



**WARNING: The solar panel needs to be cleaned monthly. The solar panel may need to be cleaned more frequently depending on weather conditions.**

### Charge Controller:

The Charge Controller was built to accommodate either Flooded Lead-Acid batteries or Absorbed Glass Mat (AGM) batteries. A jumper wire is located on the back of the circuitry and must be in place to set the float voltage of the controller to flooded wet cell batteries. Removing the jumper lowers float voltage for Absorbed Glass Mat batteries. This feature resets the charge parameters to work with either flooded wet cell batteries or AGM batteries. Float voltage changes from 14.2 to 13.4 Volts, which is what the AGM battery manufacturer recommends.



**NOTE: The Charge Controller is limited to a maximum of two 100 watt solar panels not to exceed a 7 Amp charge.**

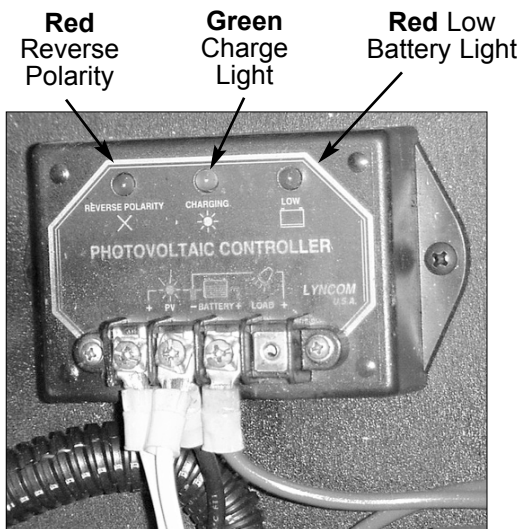

solar controller 1.tif

- The **red** Reverse Polarity light indicates reverse polarity of the solar panel connections to the controller or reverse polarity of the battery connections to the controller
- The **green** Charge light illuminates when the system is charging.
- The **red** Low light illuminates when battery voltage is below 11.5 Volts DC.

### Solar Panel Care:

A critical part of maintaining the solar powered battery charging system is keeping the panels clean. The amount of power that a panel will produce is directly related to the intensity of sunlight that reaches the internal crystals. A dirty panel will allow less light to reach the crystals resulting in reduced power output. A layer of dust or road grime can reduce power output by 15 to 25%. Combine dust with leaves and debris that cover two or three of the individual cells can reduce output power by 50 to 75%.

Use of the basic maintenance tips, regular inspections and regular cleaning will assure maximum performance from the solar charging system. To clean the panels use non-abrasive cleanser and paper towels. The surrounding environment and the amount of road dust encountered determines how frequently the panels should be cleaned. One to two times a month is preferred.



**Tips:**

1. The panels should be cleaned if a film or a layer of dust is on the windshield.
2. On a bright sunny day, charging current of two or three amps can be obtained during the peak charge cycle.
3. High winds blow dust and debris causing dirt build up on the panel. Frequently inspect the panel and clean as necessary.



**CAUTION: Avoid damage to the solar panel controller. Cover the solar panel with a blanket when replacing the batteries or performing battery cable maintenance.**

**NOTES**

# SAHARA

## SECTION 9 ELECTRICAL SYSTEMS - CHASSIS

INTRODUCTION	• 245
BATTERY DISCONNECT - CHASSIS	• 245
BATTERY CHASSIS	• 246
<i>Battery Specifications - Chassis</i>	• 247
DASH	• 248
<i>Gauges</i>	• 248
<i>Indicator Lamps</i>	• 250
<i>Switches - Dash</i>	• 252
<i>Air Conditioner &amp; Heater Controls</i>	• 254
<i>Parking Brake</i>	• 261
STEERING COLUMN	• 262
<i>Tilt &amp; Telescope</i>	• 262
SHIFTER PANEL - <i>Transmission Shifter</i>	• 263
DIAGNOSTIC PLUG LOCATION	• 264
FUSES & CIRCUITS - CHASSIS	• 264
<i>Distribution Panel - Front</i>	• 264
ALTERNATOR	• 265
<i>Check Out Procedure</i>	• 266
<i>Alternator Testing Procedure</i>	• 266
<i>Battery Isolator</i>	• 267
ECHO CHARGER	• 268





## INTRODUCTION

A majority of the lighting and appliances are designed to operate from 12 Volt DC (direct current) power. This is why the batteries play such an important role in the function of the motorhome. There are exceptions with appliances such as the microwave or television; however, indirectly they still operate from 12 Volt DC power, as they can be operated from the inverter. The chassis functions (engine, transmission, dash air, etc.) are also 12 Volt DC.

With the all technological advancements taking place in the past several years manufacturers have now incorporated electronics into these systems. It is important to keep the 12 Volt system(s) in good working order. These systems, with their incorporated electronics, are voltage sensitive. Some items can be damaged if the DC voltage is not maintained within the designed specifications.

There are two separate 12 Volt systems. One is the chassis system; the other is the house system. These two systems, for the most part, are separate from one another. The house system does not operate engine functions; as the engine system does not operate house functions. However, within the two systems there are some inner connections. For example: While the motorhome is driven the alternator on the engine will charge the house batteries. Likewise, while the motorhome is plugged into shore power, or the generator is running, the engine battery(s) are being charged. Each system will supply 12 Volt DC power to the 12 Volt distribution panels. The 12 Volt panel that services a majority of the chassis system functions is located outside by the driver's front wheel. The other panel, located in the bedroom, services the house interior functions such as the interior lighting and appliances. You should become familiar with these panels and the items they operate.

The two different systems, engine and house, have their own set(s) of battery(s). The engine battery supplies 12 Volt DC power to the front distribution panel located in an outside compartment by the driver's side front wheel. This panel contains mostly engine system fuses and wiring such as headlights, taillight, dashboard functions, gauges, etc. The house battery(s) supplies 12 Volt DC power to the distribution panel located in the bedroom. This panel contains fuses for the house, interior lighting and appliances, such as the furnace and water heater.

The main battery disconnect for the chassis battery turns the DC power on or off to the front electrical bay. Most chassis and engine functions are interrupted when the battery disconnect is turned off. Some electronic items require a constant power source for memory retention such as the dash and CB radios. Some electronic components of the engine and transmission require a constant power source. Turn the main battery disconnect switch off when the motorhome is going to be stored, or when performing electrical maintenance.

## BATTERY DISCONNECT - CHASSIS

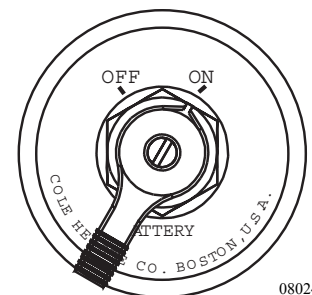



080240

If possible, leave the motorhome plugged into an AC source with the battery disconnect switch on. This will help prevent the possibility of dead batteries. If an AC source is not available, and the motorhome is not going to be used or is stored more than 48 hours, it is recommended to turn the battery disconnect switch off.



**NOTE:** The solar panel (optional) will charge the batteries with the disconnect switch off.



**WARNING:** When the frame or other welding is involved for motorhome repair, or modification, the following precautions are required to protect electronic components in the motorhome chassis:

1. Disconnect the (+) positive and (-) negative battery connection and any electronic control ground wires connected to the frame or chassis.
2. Cover electronic control components and wiring to protect from hot sparks.
3. Disconnect the wiring harness connectors at the transmission electronic control unit. Open bed storage compartment, open engine access door. The ECU is located above the transmission.
4. Do not connect welding cables to electronic control components.
5. The welding ground cable should be attached no more than two feet from the part to be welded.

## BATTERY - CHASSIS

The chassis battery operates only chassis and engine functions. The chassis battery is a crank type battery, producing the high amperage needed to start the engine. Engine starters initially require a large amount of current to crank an engine. Initial starter amperage draw exceeds 1,200 Amps. The type of application in which the engine battery is used differs from the house battery application. The engine battery state of charge remains consistent. Maintenance is still required with an engine battery. Regular electrolyte level checks and hydrometer readings, should be performed. High electrolyte consumption, or inconsistent hydrometer cell readings, may indicate a charging system problem. Perform a charging system and current draw check if the battery is exhibiting abnormal hydrometer readings.



**NOTE:** Replacement batteries should have the same cold cranking amp (CCA) rating.

**Battery Specifications - Chassis**

BATTERIES	AH (20HR)	CCA	RC (25A) MINUTES
Chassis 12 Volt Chassis 31P-LHD (2 each)		750	360
6 Volt Domestic U2200 (4 each)	450*	**	447

\*Total battery bank capacity. \*\*Battery connections are made in a Series/Parallel connection. Domestic batteries are not rated in Cold Cranking Amps (CCA).

Approximate Hours at Ampere Load					
	5 AMPS	10 AMPS	15 AMPS	20 AMPS	25 AMPS
U2200	55.0	22	12.5	9.1	7.0

Battery Amp load chart.eps

Battery State of Charge vs Voltage/Specific Gravity			
VOLTAGE	SPECIFIC GRAVITY	STATE OF CHARGE	DEPTH OF DISCHARGE
12.66	1.265	100%	0%
12.45	1.225	75%	25%
12.25	1.190	50%	50%
12.05	1.145	25%	75%
11.90	1.100	0%	100%

Voltage Reading: Battery fully charged at rest for one hour.

Battery Charge Voltage chart.eps

CUMMINS ENGINE COLD CRANKING AMPS REQUIREMENTS			
ISC	1250	CCA	12 VOLTS

CCA Rating are at 0° F. These are the minimum requirements.

**DASH -  
Gauges**

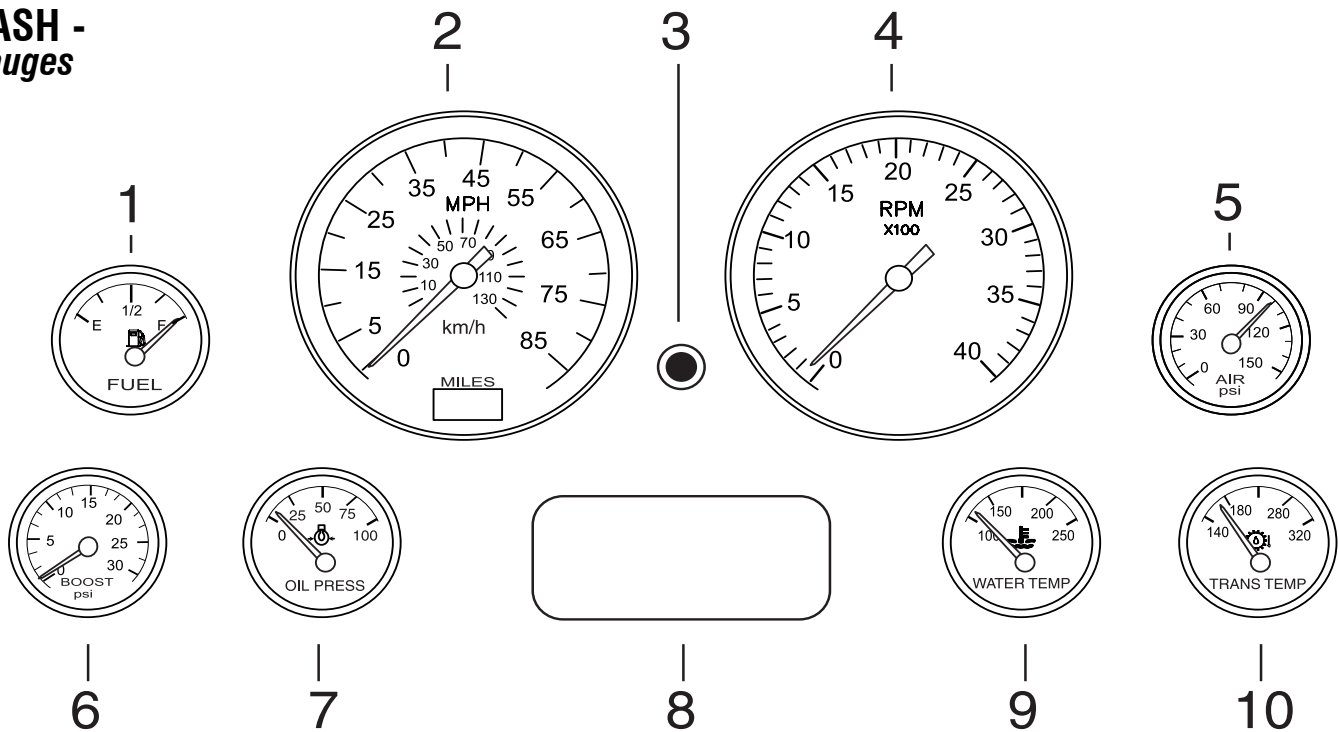

Main Dash Gauges.eps

**1. Fuel:**

Fuel gauge will register approximate fuel level in the tank when ignition switch is in the run position.



**NOTE: Fuel mileage varies with driving style and road conditions. Always average more than one tankful to obtain a more accurate figure. The diesel generator uses fuel from main tank and will affect fuel mileage figures. Diesel generators will not operate below ¼ tank to ensure there is enough fuel to run main engine.**

**2. Speedometer:**

Indicates the speed of the motorhome. The gauge indicates MPH and KPH.

**Odometer/Trip Meter:**

Records mileage driven as well as keeps track of mileage on a trip. To operate trip meter push the round black button under the speedometer. This changes odometer mileage reading to the trip mileage reading. The black reset button sets the trip mileage back to zero when held for 2 to 3 seconds. Release the button and momentarily press the button again. This changes the trip mileage reading to the odometer mileage reading.

**3. Mileage/Trip Reset Button:**

Operates the trip meter, changes the odometer mileage reading to the trip mileage reading. Press and hold to reset the trip meter.

**4. Tachometer:**

Displays engine speed in revolutions per minute (RPM).



### 5. Air Pressure Gauge:

Indicates air system pressures. The normal air system operating pressures are 105 to 120 psi. These air pressures are preset at the factory. If a problem occurs with air system not maintaining normal operating pressure it is an indication of a malfunction in the air system. Use caution and stop the motorhome in a safe area. Contact your dealer immediately.



**NOTE: It is not safe to drive the motorhome with low air pressure. Damage can occur to the suspension and drive line. The operation of the air brake system is also affected.**

### 6. Turbo Boost:

Indicates boost pressure produced by engine turbocharger.

### 7. Oil Pressure:

Indicates pressure of oil and not the amount of oil in system. Please refer to the manufacturer's instructions for specific pressure recommendations.

### 8. Dash Warning Lights.

### 9. Coolant Temp:

Under average conditions the gauge reads between 180° F and 205° F. Monitor this gauge frequently when CLIMBING HILLS, TOWING or in HIGH AMBIENT TEMPERATURES. If the gauge shows that overheating exists (the needle moving above the 212° F area) IMMEDIATE ACTION should be taken.

**Overheating may be a result of any of the following conditions:**

- Low coolant level.
- Hydraulic fan motor failure.
- Mechanical failure of hoses or belts.
- Blocking of charge air cooler fins.
- Climbing a long hill on a hot day.
- Towing a heavy trailer.
- Idling for long periods of time.

### 10. Trans Temp:

Shows temperature of transmission fluid. Normal transmission operating temperature is 160-250° F. The maximum transmission to cooler oil temperature is 300° F. Do not let the transmission temperature exceed 275° F. If excessive temperature is indicated stop motorhome and shift to neutral. Accelerate engine to 1200-1500 RPM and allow temperature to return to normal.



**NOTE: Layouts may vary with different models and options.**

## Indicator Lamps

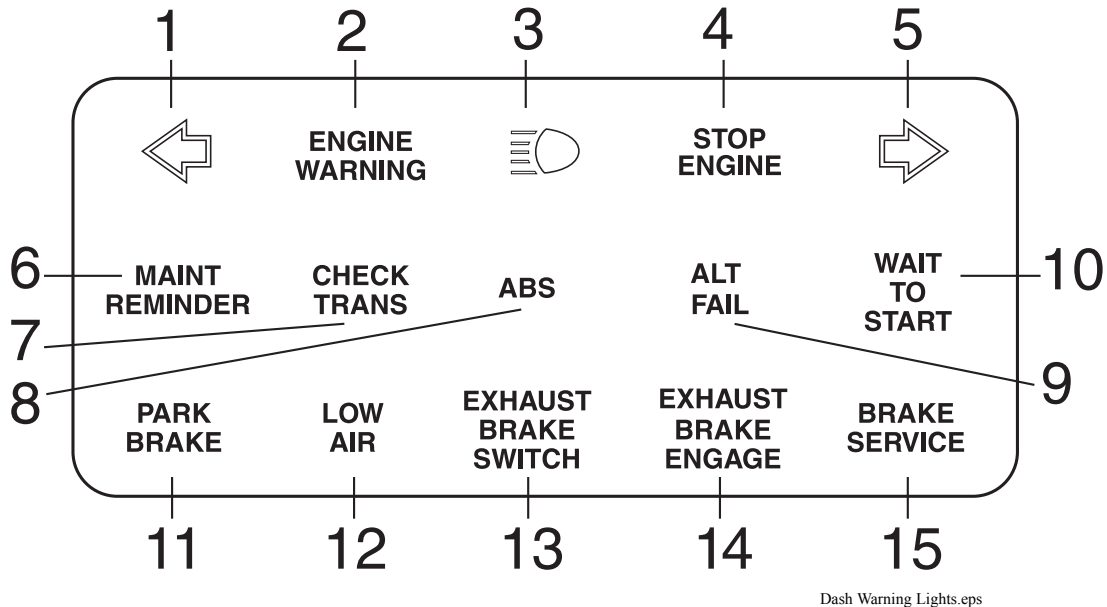

**1. Left Arrow - Audible Turn Indicators:**

Indicates left turn indicator circuits active. Audible indicator cancels when the brake is applied.

**2. Engine Warning:**

Indicates out of range condition exists within the engine protection circuits. Stop coach, check all fluid levels.

**3. Headlight Beam:**

Indicates high beams when illuminated.

**4. Stop Engine:**

Alerts driver of severe out of range condition within the engine protection circuits. Pull over and stop as soon as possible. Shut-off engine to avoid engine damage.

**5. Right Arrow - Audible Turn Indicators:**

Indicates right turn indicator circuits active. Audible indicator cancels when the brake is applied.

**6. Maint Reminder:**

Indicates it is time for the engine oil and filter to be changed. This logic circuitry must be reset to cancel the light.

To reset: Ignition on > Hold throttle 100% > 3 brake applications > Release throttle and the brake. Repeat cycle 3 times. Ignition off.

**7. Check Trans:**

Alerts driver of problems related to the Allison Transmission. The light should momentarily illuminate when the ignition is switched ON. When starting the lamp will extinguish indicating the circuits are working properly. If the lamp fails to illuminate or remains on, the transmission needs to be checked immediately. Contact the nearest Allison dealer.

**8. ABS:**

Indicates ABS possible fault in the ABS Brake system. Also indicates faults codes for service technicians.

**9. Alt Fail:**

Indicates a failure within the alternator charging system.

**10. Wait to Start:**

Monitors the air intake heater at start. Only used with the ISC engine.

**11. Park Brake:**

Indicates parking/emergency brake is applied.

**12. Low Air:**

Indicates air tank pressures are out of operating range. Check air pressure.

**13. Exhaust Brake Switch:**

Indicates the exhaust brake switch is on.

**14. Exhaust Brake Engage:**

Indicates the exhaust brake is active.

**15. Brake Service:**

Indicates a malfunction in the hydraulic brake system. Contact a brake servicing facility.

## Switches - Dash

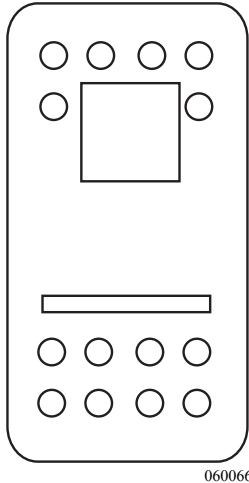

Typical lighted switch.

### **FAST IDLE:**

This switch will increase and decrease the engine idle in 25 RPM increments. There are limits to the idle speed, about 700 to 875 RPM.

### **CRUISE POWER:**

Enables the cruise control.

### **SET/RESUME Switch:**

The Cruise Control and Set/Resume switches are used together to provide cruise operations and can be used to control idle operations.

- To establish cruise speed:  
Accelerate to the desired speed. Press the switch to **SET**.
- To cancel the cruise control:  
Step on the brake. Press the switch to Resume to accelerate to the pre-programmed speed. Turning the Cruise Power switch off cancels the cruise control.

When the Cruise is on and the Resume is pushed momentarily, the idle will jump to 200 RPM. If the Resume is pushed a second time, the idle will max out at 1,300 RPM. This is the high idle function. Both operations are cancelled when the service brake is applied. The Set switch, when pushed while driving, will store the parameter for use by the EMC. After a service brake application, speed can be restored by briefly pushing Resume. If the cruise operations are in effect, holding down the Resume switch will cause the ECU to increase the parameters.

### **ICC LIGHTS:**

Pressing the momentary switch flashes the headlights and taillights when the headlight switch is off. Pressing the momentary switch turns off the taillights and marker lights when the headlight switch is on.

### **BACKUP CAMERA:**

Turns the backup camera on and off.

### **EXH BRAKE:**

This switch activates the control solenoid for the engine brake system.

### **ENG DIAG:**

Checks engine functions.

### **DRVR SHADE:**

Operates the power sun visor located on the driver's side.

### **PASS SHADE:**

Operates the power sun visor located on the passenger's side.

**WIPER WASHER:**

Turn knob clockwise for variable speed, low and high wiper function. Press knob for washer function.

**HEADLIGHT SWITCH:**

Pull switch to first detent for marker lights. Pull switch to second detent for headlights and marker lights. Rotate switch for backlight intensity.

**DRIV'G LIGHTS:**

Enables the driving lights located below the headlights. Headlights must be on high beam in order to function.

**BATTERY BOOST:**

The Battery Boost switch is used in the event the motorhome chassis battery has been drained or is at a low charge level where the engine cannot start. This switch momentarily “jumps” the house battery to the motorhome domestic battery to assist in starting the engine. The boost switch, used in conjunction with engine starting procedures, should not be held for more than 30 seconds. This time period is long enough to prevent the boost solenoid from overheating.

**GEN START:**

The generator automatically initiates a preheat cycle when the switch is pressed to Start. The preheat cycle is indicated by the light on the switch flashing rapidly. Depending on ambient temperature the preheat cycle may last up to fifteen seconds.

**To Start the Generator:** Press and hold the switch to Start. The light will flash rapidly indicating the preheat cycle. At the end of the preheat cycle the engine will crank and start. Release the switch after the generator has started and is operating smoothly.

**To Stop the Generator:** Momentarily press the switch to Stop. It is not necessary to hold the switch until the generator has stopped.

**BLOWER SWITCH:**

Operates the overhead blower.

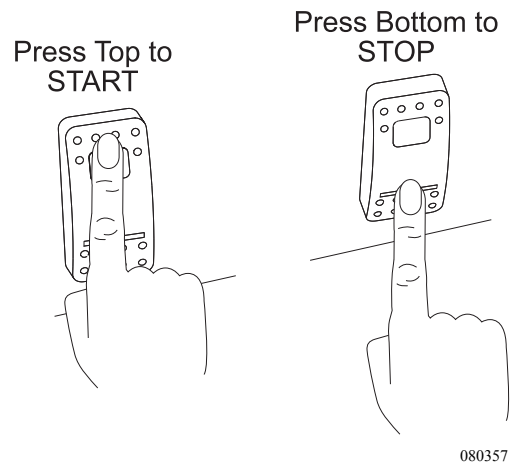

## **Air Conditioner & Heater Control**

### **Dash AC and Heater Control:**

The system is designed to only provide heating, cooling and defrost capabilities for the pilot/co-pilot area. The system is not capable of heating or cooling the entire motorhome.

### **Blower Operation:**

The blower is selected automatically when the desired feature is selected with the **SELECT** switch. The system is shut off by placing the mode control switch in the “**OFF**” position.

### **A/C Operation:**

The A/C dash system will operate in all modes except **VENT**, **FLOOR** and **OFF**. The **A/C** and **MAX** positions engage the A/C compressor. When the switch is positioned in the **A/C** mode fresh air is drawn through the front air intake of the unit through the A/C coil. In the **MAX** position a damper door closes off the fresh air, while another door opens to permit only air from inside the coach to be used. When maximum cold air is desired this position should be selected. Also use this position when you do not wish to introduce outside air into the coach.

### **Air Distribution Switch (Mode Control):**

Used to direct air where it is needed to maximize the comfort of the motorhome.

### **Temperature Control Switch:**

Controls an electric water valve regulating the amount of engine coolant passing through the heating and cooling coils in the system. Rotating to the red area provides warmer air; rotating to the blue area provides cooler air.

### **Blower Speed Control Switch:**



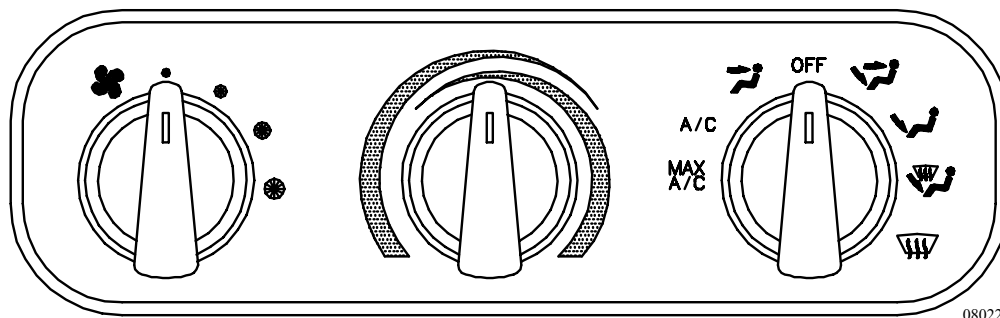

Controls the speed of the blower motor, which is one of the best and most effective ways of controlling the temperature. The switch provides four speeds in all modes except **OFF**.



*Blower Speed Control*

*Temperature Control*

*Mode Control Switch*

<b>MAX A/C</b>	<b>MAX A/C</b> - Recirculated air is drawn from the passenger area and discharged through the dash louvers.	
<b>A/C</b>	<b>A/C</b> - Fresh Air is drawn from outside into the system and discharged through the dash louvers.	
090273		<b>VENT</b> - Fresh air is drawn in and discharged throughout the dash and defrost louvers.
<b>OFF</b>	<b>OFF</b> - The blower motor does not operate. The fresh air inlet door closes, minimizing outside air infiltration into the the motorhome.	
090274		<b>BI-LEVEL</b> - Fresh air is drawn in and discharged through the dash, floor and defrost louvers.
090275		<b>FLOOR</b> - Fresh air is drawn in and discharged through the floor louvers. A small amount of air is used to defrost the windshield.
090276		<b>MIX</b> - Fresh air is drawn in and discharged through the floor and defrost louvers. The A/C system operates to dehumidify the discharged air.
090277		<b>DEFROST</b> - Fresh air is drawn in and discharged through the defrost louvers. The A/C system operates to dehumidify the discharged air.

**Winter Use:**

- De-ice the windshield using the **DEFROST** mode.
- Air will heat up faster with a slower blower speed until normal operating temperature ranges are reached.

**Summer Use:**

- Close all windows and vents to hot, humid outside air.
- **MAX A/C** and **HI** blower will provide quick cool down.
- Use a lower blower speed to produce cooler air.

**Operating tips and hints:**

Air intake and discharge temperatures are greatly affected by ambient temperatures and relative humidity. A large amount of cooling capacity is used to dehumidify air as well as cool it. After three to five minutes of A/C operations the discharged air temperature should be approximately 30° F cooler than the fresh or recirculated air entering the AC system.

**Troubleshooting:**

The dash A/C/Heat system uses a combination of compressed air (developed by the chassis system), vacuum air (developed by the vacuum generator) and electric relays and vacuum switches. Therefore, any repair can be classified in one of five categories:

- Electrical • Vacuum • Air Conditioner • Heater • Defroster



**NOTE: Operate the air conditioning compressor once a month to maintain lubrication of compressor seals and other internal components of the system. If the air conditioning system has not been operated for longer than one week, initially engage the compressor when the engine is at an idle. This prevents sudden high-speed operation of non-lubricated compressor components.**

The following information is provided to assist in troubleshooting common operational problems which may occur.

**No Heating:**

1. A/C switch is turned off.
2. Blower switch is turned off.
3. Verify the proper engine coolant level.
4. Verify that the engine is reaching operating temperature.
5. Verify engine coolant is reaching water valve attached to unit.
6. Verify operation of water valve to permit engine coolant to pass through valve to heater core.
7. Check unit fuses.
8. Check power supply to water valve and grounding.
9. Check wiring.
10. Engine thermostat faulty.

**No Cooling:**

1. Check blower is operating, A/C switch is in A/C or **Max** position, temperature control is turned to **Max** cooling (blue area).
2. System fuses are not blown.
3. Condenser fan is operating.
4. Check power supply to unit and grounding of system.
5. Check wiring.
6. Coolant valve leaking.
7. Drive belt loose or broken.
8. Compressor Clutch inoperative, will not engage.
9. Expansion Valve faulty or frozen.
10. Thermostat control faulty.
11. Mode control switch faulty.
12. Compressor faulty.
13. Loss of refrigerant.



**Reduced Cooling:**

1. Coolant valve not operating correctly.
2. Air passages obstructed.
3. Loose or worn drive belt.
4. Check blower and select switch.
5. Thermostat control valve faulty.
6. Expansion valve faulty.
7. Compressor faulty.
8. Low refrigerant charge.

**Blower Does Not Operate or Runs Slow:**

1. Check fuses.
2. Check for loose or corroded connection.
3. Check wiring.
4. Check ignition switch is "ON."
5. Check blower and select switch.
6. Motor shaft seized.
7. Blower wheel out of alignment.

**Damper Doors Do Not Operate:**

1. Does motorhome air tank have pressure?
2. Check vacuum generator is being powered and producing vacuum.
3. Check vacuum line entering unit for vacuum.
4. Check that the vacuum solenoid mounted on unit is receiving power from the mode switch. If operating properly, the vacuum solenoid will feel hot if current is engaging the solenoid.
5. Check mode switch.
6. Check wiring.
7. Check for pinched vacuum line leading to the vacuum motor operating the damper door in question.

## **Air Conditioner Refrigeration Components:**

### **Compressor:**

The compressor is belt driven from the engine through the compressor and electronic clutch pulley. The compressor will pump freon from a low pressure gas into a high pressure, high temperature gas. This is the start of the refrigeration process.

### **Condenser:**

The condenser in front of the radiator is made of coils and fins which provide rapid transfer of heat from the refrigerant as external air passes over the coils. The high pressure gas is changed to a high pressure liquid.

### **Condenser Fan:**

A steady flow of cooling air is maintained across the condenser during system operations. The fan is part of the hydraulic system.

### **Receiver-Drier:**

Freon leaves the condenser, enters the dehydrator and is stored until needed. The drier filters out moisture in the system. It only takes one drop of moisture to cause a malfunction in the cooling unit.

### **Expansion Valve:**

The expansion valve suppresses the refrigerant into the evaporator according to the cooling requirements. The pressure is reduced in the restrictive effort of the expansion valve. A part of the valve is the capillary tube assembly. The capillary tube is the sensing bulb at the outlet of the evaporator.

### **Evaporator:**

A tube core and fins are used in the evaporator similar to the condenser. Air is blown through the fins to allow the evaporator to cool and reduce the pressure.

### **Blower and Motor:**

Just as the condenser has a fan, the evaporator has a fan called the blower. The blower will draw air from the cab area and force the air over the evaporator coils and fins. This forced air will ensure continuous vaporizing of the R134a.

### **Relays and Switches:**

Both electronic and vacuum switches are used in the control and operations of the system.

**Chemical Stability:**

The air conditioning system life and efficient operations depends upon the chemical stability of the refrigeration system. The refrigeration system is made of Refrigerant-R134a and Polyakylene Glycol (PAG) synthetic lubricant. It is very important that all materials contained within the refrigerant system be chemically compatible. The only suitable compound for use with R134a is PAG. The total amount of PAG within the refrigerant system is approximately 18% of the total refrigerant in the system.

How much refrigerant is in the system. How much should be used when charging? You will need 1 oz. of PAG for each 7 feet of hose after the first 15 feet of hose. Roughly, a 40 foot motorhome will use 92 feet of refrigerant hose. Take 15 feet off the measurement and the result would be 77 feet. This 77 feet is then divided by 7 for total of 11. This represents the number of ounces of PAG oil needed for the A/C system (11 oz.).

Carrying the formula one step further, the 11 oz. equal approximately 18% of the entire system. The total will equate to approximately 61 oz. or 3.8 lbs. of R-134a.

High pressure readings are another way to determine the amount of charge. The ambient temperature reading is measured one inch away from the condenser. The ambient temperature reading, plus 40°F, will equate to a value from the pressure table.

**EXAMPLE: 90° F**  
**1 inch from condenser**  
**+40°F**  
**130°F ----- 198.90**

**PSIG** - On fully charged system the expected pressure that should be seen on the HIGH-SIDE gauge will be around 200 PSIG.



**NOTE: All systems are charged at the factory with 4.0 lbs of R134A.**

TEMP F/ PSIG		TEMP F/ PSIG		TEMP F/ PSIG	
16	15.69	60	57.47	112	151.30
18	17.04	65	64.10	114	156.10
20	18.43	70	71.19	116	161.10
22	19.73	75	78.75	118	166.10
24	21.35	80	86.80	120	171.30
26	22.88	85	95.40	122	176.60
28	24.47	90	104.40	124	182.00
30	26.10	91	106.30	126	187.50
32	27.79	92	108.20	128	193.10
34	29.52	93	110.20	130	198.90
36	31.32	94	112.10	135	213.70
38	33.17	95	114.10	140	229.40
40	35.07	100	124.30	145	245.80
42	37.03	102	128.50	150	263.00
44	39.05	104	132.90	155	281.00
45	40.09	106	137.30	160	300.10
50	45.48	108	141.90	165	320.00
55	51.27	110	146.50	170	340.80

### **R-134a Refrigerant:**

R134a is classified non-explosive, non-flammable and non-corrosive. It has hardly any odor and is much heavier than air. R134a is ozone friendly; however, it is not technician friendly. Proper care in handling and adequate ventilation is a must. Under normal atmospheric pressures and temperatures R134a evaporates so quickly it freezes anything it comes in contact with. The open container boiling point for R134a is minus 21.7° F, which makes it an ideal refrigerant. The tremendous amount of heat transfer which occurs when a liquid boils, or vapors condense, forms the basic principles of all A/C systems. The amount of heat required to raise or lower the temperature of 1 lb. of water by 1° F equals 1 BTU (British Thermal Unit). The BTU is the standard measurement of an air conditioner system.

### **Safety and Handling of 134A and Pag Oil:**

- Wear eye and hand protection when working with any refrigerant system.
- Pag Oil irritates the skin. Flush with water immediately if in contact with any body part.
- Service work performed on the A/C system must be performed in a well ventilated work area.
- Keep open flame away from service area. The discharge of a refrigerant gas near an open flame can produce a very poisonous gas.



**NOTE: O-rings used in a 134A system are Hydrogenated Nitrile Butadiene Rubber (HNBR). These are green in color and required for the 134A system.**

### **A/C Heater:**

The A/C system will also produce heat to warm the air in the dash area. Much like the refrigeration side of the system, a liquid will be used in the process. This liquid is the engine coolant. The coolant is passed from the radiator to an electronic water valve. The water valve, when open, will allow the coolant to flow through the heater core. The heater core is tubing and fins. Air is drawn into the system by a blower motor through the outside recirculation door opening. Air is blown through the A/C evaporator core and then through the heater core. When the temperature control is in the **WARM** position coolant flows through the heater core. When the temperature is in the **COOL** position coolant flow bypasses the heater core. In either position the air flow is felt at the discharge vents.

### **Diagnosis of Electric Water Valve:**

Theory of Operation: Models with a center dial temperature control use a potentiometer at the control head for input of desired temperature. The water valve, which controls the water flow to the heater core, is opened and closed by a stepper motor mounted on the water valve. A control module compares the output voltage from the control to that of the feedback for the stepper motor of water valve. The control module then drives the motor to within one-half Volt of the control potentiometer voltage.

**Functional Test:**

- Start and operate the engine until the water reaches normal operating temperature.
- Set the HVAC temperature control to the full hot position.
- The discharge air outlets should have hot air.
- Rotate the temperature control to full cold position.
- Allow 10 minutes for the temperature to stabilize.
- The discharge air outlets should have cold air.

**No Heat:**

- Check the blower and air mode operations. Fix or repair prior to proceeding.
- Verify the engine is reaching normal operating temperature. (Check with engine manufacturer for proper procedure.)
- Check the inlet hose at the water valve. The hose has hot water at the valve inlet. The inlet water temperature should be the same as the engine water temp.
- With the temp control on full hot position, check the outlet hose of the water valve. The hose should be at engine water temperature.

**Vacuum Generator:**

The vacuum generator operating from 12 Volts DC creates the vacuum necessary to operate the damper door vacuum motors. When selecting different air discharge ports using the Mode Control switch, the door selected opens at the plenum. Other doors remain closed until that door is selected. The vacuum generator operates between 12-17 inches of vacuum. A round storage reservoir ball is placed in the system to overlap between system demand and vacuum created.

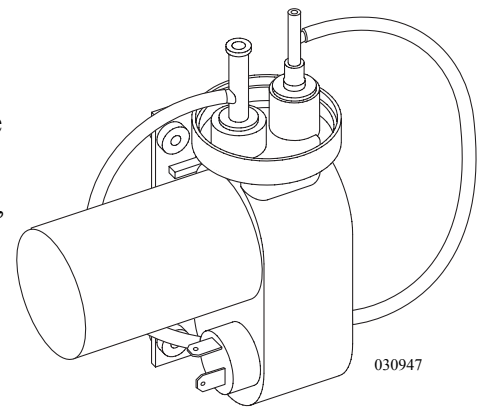

The parking brake system is activated when the push-pull control knob (located on the driver's left console panel) is pulled. When the knob is pushed, the brake is released. Prior to driving, allow time for the air compressor to build up sufficient air to shut off the air warning lamp.



**WARNING: If the air tank is not dumped, there is the possibility of an accidental release of the parking brake. Traveling with small children and/or pets may require a small block to be fabricated to prevent accidental release. The block should be placed under the knob and rested on the dash panel. A wooden clothes pin clasped at the base of the shaft will work.**

**Parking Brake**

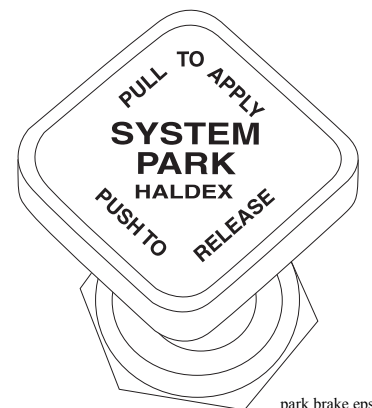

## **STEERING COLUMN - Tilt & Telescope**

Tilt and telescope steering wheel control lever is located on the steering column.

- To tilt the steering wheel pull the lever up. Tilt the steering wheel to the desired position. Release the lever and the steering wheel will lock in the new position.
- To telescope the steering wheel push and hold the lever down. Push down or pull up on the steering wheel until the wheel is in the desired position. Release the lever and the steering wheel will lock in the new position.

### **Turn indicator and headlight high/low dimmer control lever is located on the steering column:**

- Pushing the lever forward will activate the right turn indicator circuits when the ignition is on.
- Pulling the lever down will activate the left turn indicator circuits when the ignition is on.
- Pulling the lever up will select high/low beam circuits when the headlights are ON.

### **Hazard Flashers: Flasher button is located on the steering column.**

- Pull out on flasher button to turn four way flasher on.
- Push button inward to shut off flasher.

For Turn Signals  
Move Stick Right or  
Left-For Bright or Dim  
Headlights Pull Up and  
Release

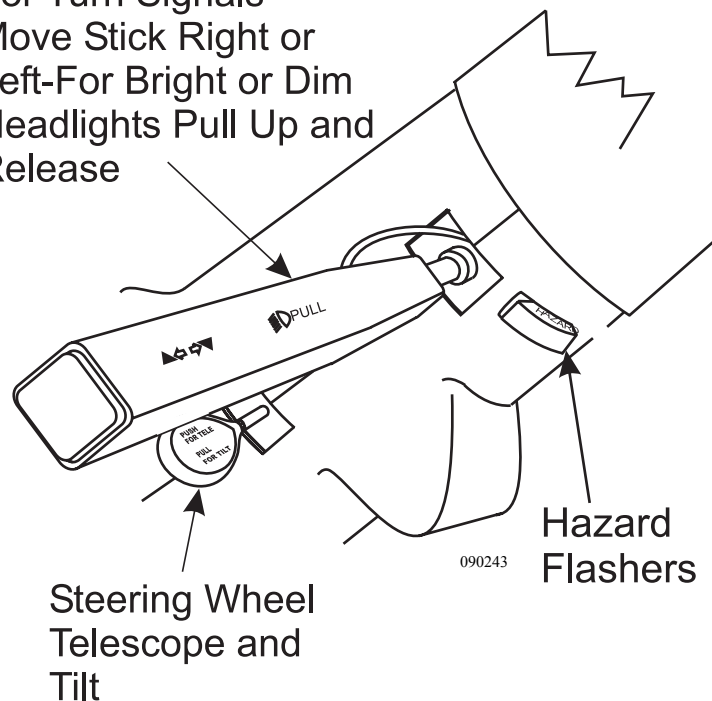

**Transmission Key Pad:**

The function of each position of the keypad push-button shifter is as follows:

- Select the **REVERSE** gear by pressing **R**.
- Select **NEUTRAL** by pressing **N**. The area around the **N** button has a raised ridge so the driver can orient his hand to the push buttons by touch, without looking at the display.
- Select **DRIVE** range by pressing **D**. The highest forward gear appears on the **SELECT** display and the transmission will shift to the starting gear.
- The **UPSHIFT** and **DOWNSHIFT** **arrow** buttons are used to select a higher (if not in **D**) or lower (if not in **1**) forward range. These buttons are not functional in **NEUTRAL** or **REVERSE**. One press changes the range selected by one range. If the button is held continuously the selected range will continue to change up or down until the button is released or until the highest/lowest possible range of gears is selected.
- The fluid level of the transmission can also be checked from the shift selector keypad. Press the **Up** and **Down** arrow button simultaneously while the motorhome is at a rest position. This activates the diagnostic circuitry of the transmission. To exit the diagnostics press **N**.

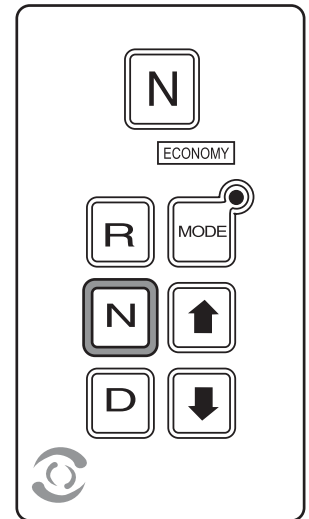
**SHIFTER PANEL  
Transmission Shifter**

080355B



**NOTE: The oil level sensor method of checking the fluid level compensates for transmission fluid temperature between 60° C - 104° C (140° F - 220° F). Any temperature below 60° C (140° F), or above 104° C (220° F) will result in an Invalid for Display condition.**

- The **MODE** button will enable the secondary shift point to be selected. The transmission shift point used will be 200 RPM lower. It is further used by a service technician to access diagnostic codes when troubleshooting. The diagnostic circuitry must be enabled to display the codes.

**To Enter Economy Mode:**

Press the **MODE** button. The LED will illuminate.

**To Exit Economy Mode:**

Press the **MODE** button. The LED will extinguish.

- When the Auxiliary Braking device is used, the display will change to default reading of two or three. This default is pre-selected at the factory and can only be reprogrammed by an authorized Allison Service center. The transmission is not in second or third gear. This is only the reference for the RPM shifts points to optimize the braking capacity.



**CAUTION: Do not use the economy mode in heavy stop and go traffic or mountainous terrains. While in economy mode using heavy throttle applications with frequent shifting will raise transmission fluid temperature. Exit economy mode until road conditions improve.**

## DIAGNOSTIC PLUG LOCATION

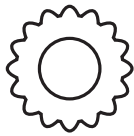

Diagnostic Plug.

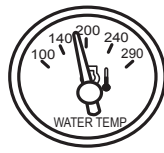

040458

The Cummins diagnostic plug is located in the curbside engine service bay.

## FUSES & CIRCUITS - CHASSIS Distribution Panel - Front

The front electrical panel is located on the roadside, ahead of the front wheel. It contains the fuses, self resetting supply circuit breakers, solenoid and relays.

The automotive fuses and emergency flashers are located in the front electrical panel. The fuses are the standard plug-in type (ATO). When a fuse “BLOWS,” the wire in middle of the plastic case will be broken. A bad or blown fuse must be replaced with a fuse of the same rating and type. Using a fuse of a different type rating will defeat the circuit protection provided by the fuse, which could result in damage to the motorhome’s electrical system. If a fuse has been replaced and it “BLOWS” repeatedly, that may be an indication that a fault exists or an electronic component has failed. It is recommended that the motorhome be taken to a qualified RV technician before any future use to diagnose and repair the problem. Circuits are identified on the fuse label located on the inside of the electrical compartment door.

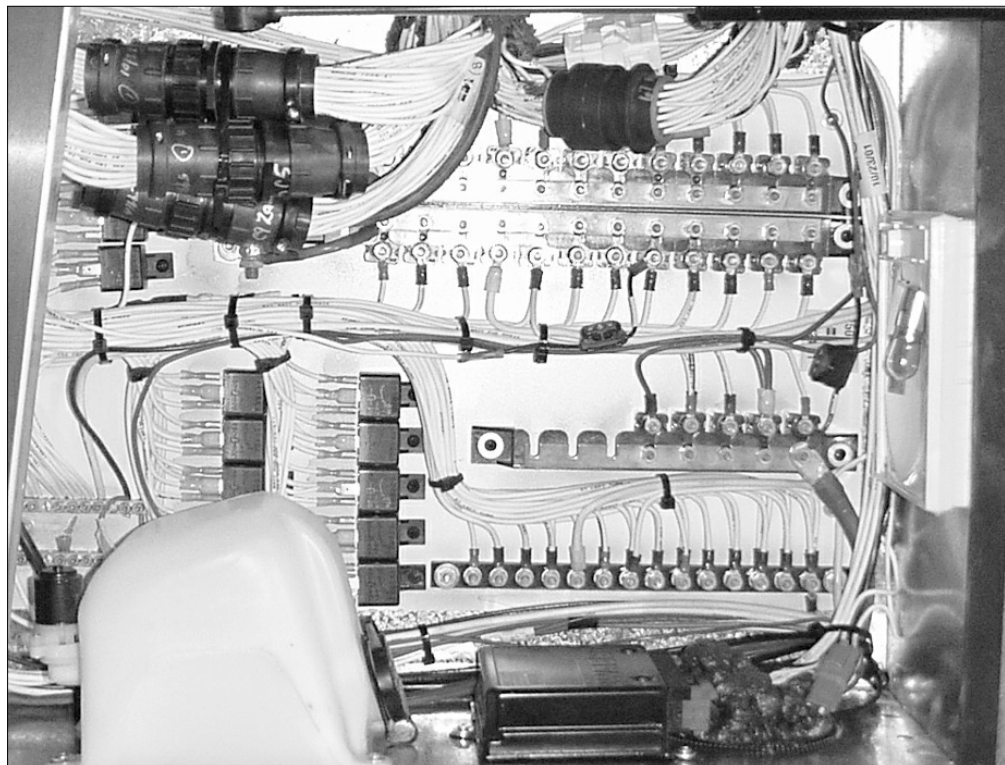

Front Distribution Panel.

front run panel.jpg



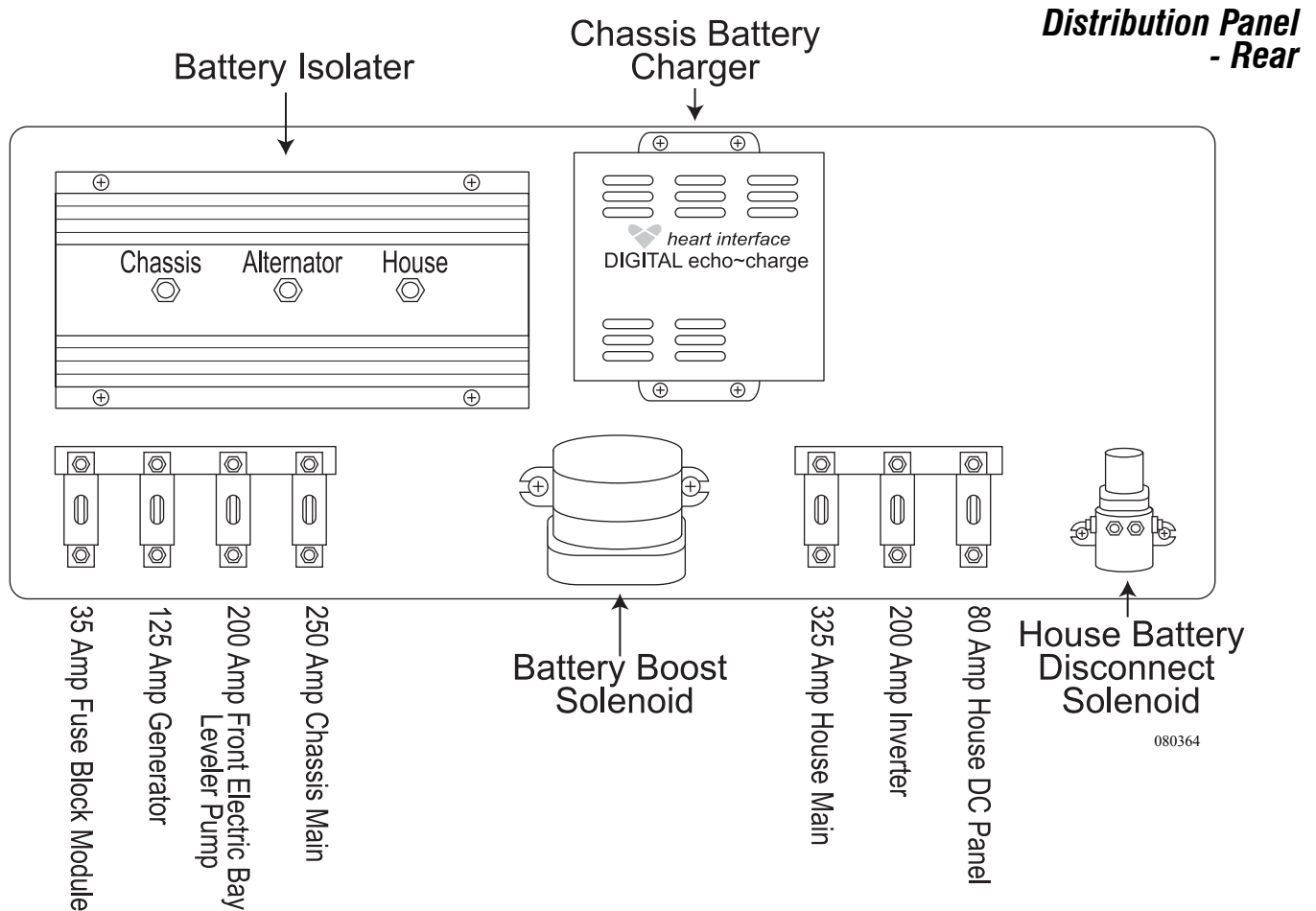

Rear Distribution Panel.

The Leece-Neville alternator with integral rectifier, regulator and remote voltage sensor is designed for reliable output throughout the engine operating range. When traveling, keep an eye on the voltmeter in the dash area. Normal readings should be between 13 to 14.5 Volts. Voltage indications higher or lower indicate a problem with the charging system. If the alternator output drops below an acceptable level, a charge indication warning lamp will illuminate.

The alternator replaces the amp hours the chassis battery uses to start the engine. The amount of charge to the batteries is dependent on the amount of time the engine is operated. Repeatedly starting the engine and driving the motorhome for a short distance, or short periods, may not be enough operating time to adequately replace the amp hours used to start the engine.

## ALTERNATOR

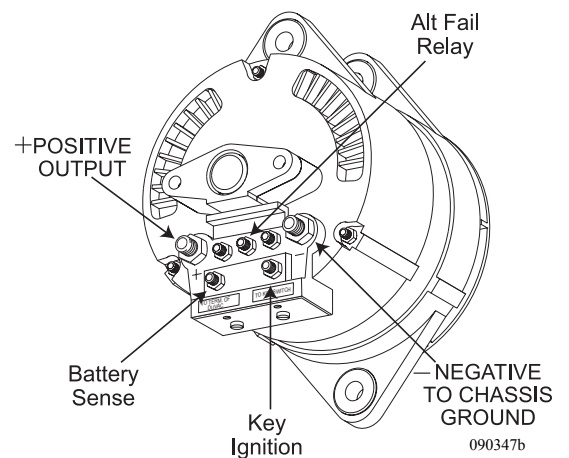

## Check Out Procedure

The alternator also maintains a charge to the house batteries. The function of the alternator is an electrical system voltage maintainer, not a battery charger. When traveling the alternator maintains electrical system voltage relative to any loads, such as headlights and windshield wipers. When a heavy load is placed on the alternator, such as trying to charge dead batteries, the operating temperature of the alternator increases dramatically. Excess operating temperature of the alternator for extended periods of operation can lead to premature failure of the alternator.

If the house batteries are in a low state of charge, or dead, before traveling it is recommended to charge the house batteries with the inverter or an auxiliary battery charger.

### Specifications:

- 145 Amp standard
- The integral rectifier system utilizes 12:50 Amp diodes mounted in multiple aluminum heat sinks for efficient heat dissipation during high-output operation.
- Aluminum housings
- Bi-directional fan
- Front bearing: 305 cartridge type
- Enclosed brush system
- Operation Ambient Temperature Range (-40° to 200° F.)
- Negative Ground Configuration
- Regulator Adjustment Range 13.6 to 15.4 Volts
- Batteries may start to gas at 14.3 Volts
- Max. Operating RPM 8,000

## Alternator Testing Procedure

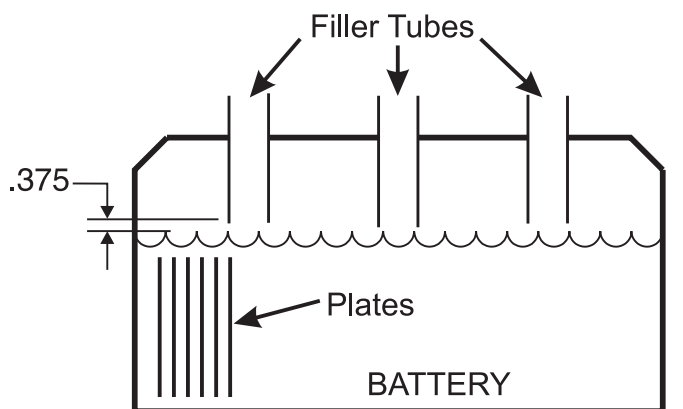

The distilled water level in the battery should be 3/8" below the vent tube.

020034

### Alternator Testing Procedure:

- Check all wiring for burnt or loose electrical connections. Repair as needed.
- Check all grounds and electrical connections to be sure they are clean and tight.
  - a. Alternator ground to chassis frame.
  - b. Motor block ground to chassis frame.
  - c. Chassis battery ground to chassis frame.
  - d. Alternator positive output to isolator center terminal.
- Inspect the alternator for damage. A broken fan blade can damage an alternator or make it out of balance.
- Check belt, pulley and fan for wear. Replace as needed.

- Never attempt to disconnect the battery or battery wire from the alternator with the engine running. This can cause damage to the alternator or the regulator.
- The pulley for the alternator should be torqued to 80 foot pounds.
- Chassis battery voltage, with the engine OFF, should range from 12.2 to 12.7 Volts DC.
- Chassis battery voltage with the engine at idle, should range 13.5 to 14.2 Volts DC.
- The output of the alternator range is 13.6 to 15.4 Volts DC.  
Connect a voltmeter to the (B+) terminal of the alternator and chassis ground. Idle the engine up to 1,200 RPM.
- Connect a clamp-on amp-meter, if available, to the positive battery cable to verify the battery state/rate of charge.



**NOTE: Remember the alternator is not a battery charger. It is designed to maintain proper electrical system voltage. A battery with a low state of charge, or a dead battery, may overheat and damage the alternator.**

The battery isolator distributes the charge current of the alternator to the house and engine batteries when the engine is running. Diodes in the isolator allow DC current to flow in one direction only preventing a backward flow of DC current. When the engine is off the chassis and house battery systems are separate. There is a typical voltage drop of .09 to 1.1 Volts DC between the input terminal and the output terminals of the isolator when the engine is running.

### **Battery Isolator**

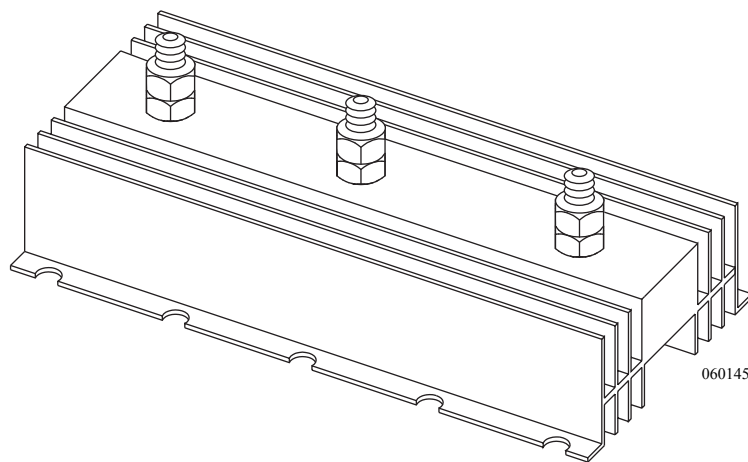

200 Amp Standard

## ECHO CHARGER

The Echo Charger is a fully automatic device that sends a charge voltage to the chassis battery whenever the motorhome is plugged into shore power, or operating from the generator.

- The Echo Charger activates when house battery voltage rises above 13.0 Volts DC. The charger deactivates when house battery voltage drops below 13.0 Volts DC.
- The charger provides up to a 15 Amp charge to the chassis battery.
- If the chassis battery voltage is low, a clicking sound may be heard from the charger. The clicking sound is an automatic reset circuit breaker inside the charger. The clicking sound is normal and indicates that the chassis battery is trying to draw more than 15 Amps. The clicking sound will stop as soon as the chassis battery has recharged.
- While dry camping with the generator off, the charger is inactive.



**NOTE: The Echo Charger is not designed to charge a dead engine battery. An auxiliary charger will be needed.**

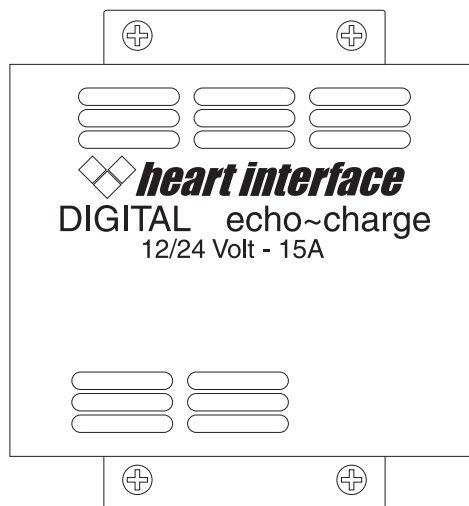

Heart Interface.eps

# SAHARA

## SECTION 10 CHASSIS INFORMATION

- INTRODUCTION • 271**
  - Chassis • 271*
  - Towing System • 271*
- AIR SUPPLY SYSTEM • 272**
- AIR GOVERNOR • 273**
  - AIR DRYER • 273**
    - Air Dryer Filter • 273*
- AIR STORAGE TANKS • 274**
- AIR COUPLER - UNIVERSAL • 274**
- SUSPENSION AIR RIDE BAGS • 275**
  - Checklist - Air Bag Inspections • 276*
- SHOCK ABSORBERS • 277**
- SUSPENSION • 278**
- ALIGNMENT SPECIFICATIONS • 279**
- BRAKE SYSTEMS • 281**
- BRAKE - PARK & EMERGENCY SYSTEMS • 281**
- BRAKES - ABS SYSTEM (*Anti-lock Brakes*) • 281**
- BRAKES - EXHAUST BRAKE SYSTEM • 281**
  - Exhaust Brake Maintenance • 282*
- BRAKE MAINTENANCE & TROUBLESHOOTING • 283**
  - BRAKES - AIR OVER HYDRAULIC • 283**
    - Bleeding the System • 284*
- FRONT AXLE (Oil Filled Bearings) • 285**
- LEVELING SYSTEM - Hydraulic Leveling • 285**
  - Manual Leveling System • 286*
  - Manual Retract Valves • 287*
- ENGINE - GENERAL INFORMATION • 288**
  - ENGINE • 289**
  - STARTING PROCEDURE • 290**
- STARTING PROCEDURE - COLD WEATHER • 290**
- OIL RECOMMENDATIONS (Engine) • 290**
  - Oil Recommendations - Cold Weather • 292*
- ENGINE SHUTDOWN • 293**
  - ENGINE SHUTDOWN - Extended • 293**
- COOLANT • 293**
  - Coolant - Additive (SCA) • 295*
  - Coolant Hoses • 295*
  - Coolant System - Thawing • 296*
- TRANSMISSION • 296**
  - Shift Selector • 296*
  - Transmission - Check Light • 298*
  - Transmission - Periodic Inspections • 299*
- TRANSMISSION LUBRICATING FLUID • 301**
  - Transmission Fluid Level - Cold Check • 302*
  - Transmission Fluid Level - Hot Check • 303*
- FUEL REQUIREMENTS • 303**
- FUEL TANK • 304**
- FUEL/WATER SEPARATOR • 304**
- FUEL LINES & HOSES • 305**
- HYDRAULIC SYSTEMS • 305**
  - Hydraulic Reservoir • 305*
- STEERING GEAR • 306**
- AIR FILTER MINDER • 307**
- AIR FILTER - Changing • 307**
- DRIVE AXLE LUBRICANT • 308**
- DRIVE SHAFT • 308**
  - U-Joint Angles, Phasing & Driveline Balance • 309*
- LUBRICATION CHART • 310**
- PARTS - COMMON SOLENOIDS & SENDERS • 312**
- CHARTS - FILTERS & BELTS • 313**
- CHARTS - SPECIFICATIONS • 314**
- CHART - METRIC CONVERSION • 316**
- MAINTENANCE RECORD • 317**

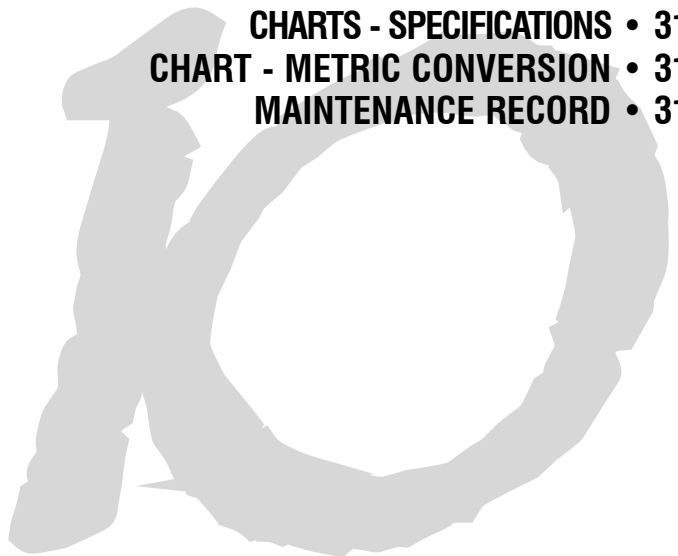



## INTRODUCTION

This section contains knowledge and information on various components of your motorhome chassis. Following the guidelines and procedures will help you to understand and operate your motorhome. Complete instructions for various components can be located in the operator's manual included in the Owner's Information File box.



**WARNING: When frame or other welding is involved for motorhome repair or modification the following precautions are required to protect electric components in the motorhome chassis.**

- 1. Disconnect the (+) positive and (-) negative battery connection, and any electronic control ground wires connected to the frame or chassis.**
- 2. Cover electronic control components and wiring to protect from hot sparks.**
- 3. Disconnect the wiring harness connectors at the transmission electronic control unit.**
- 4. Do not connect welding cables to electronic control components.**
- 5. Attach the welding ground cable no more than two feet from the part to be welded.**

---

The design of the Magnum chassis provides exceptional balance, handling and braking characteristics. The rear engine chassis is an engine and frame unit featuring a C-channel frame, providing exceptional structural integrity and uniform stress distribution. Incorporated in the Magnum chassis is the trailing-link air suspension system using frame-mounted air bags and shock absorbers. The air suspension system uses air from the air system to pressurize the air bags. Height control valves regulate the air pressure to the air bags maintaining proper ride height throughout the load range. The chassis is equipped with a three-point hydraulic leveling system. The setup and design of the chassis provides a smooth ride throughout the load range with trouble-free service, while delivering excellent drivability.

### ***Chassis***

---

The towing system incorporated in the construction of the frame is rated at 5,000 lbs. towing and 500 lbs. tongue weight. A weight distributing hitch system can place excess torsion to the receiver therefore not recommended in towing applications.

### ***Towing System***

## AIR SUPPLY SYSTEM

The air compressing system on the motorhome is comprised of several items: an air compressor, air governor, air dryer and air tank(s). The compressed air system operates several items, some of which include air brakes, suspension, an air gauge (depending on options) and stepwell cover. A gear driven air compressor mounted on the engine charges the system. As engine speed increases, compressed air output increases. When air is compressed, heat is generated. Heat dissipates as the air is discharged from the compressor. Moisture condenses in the compressed air as it cools. Moisture laden air enters an air dryer (air over hydraulic brake models) where the air is filtered. The filtered air charges the air tank. The air tank is divided in two halves: a wet side and a dry side. The compressed air enters the wet side before entering the dry side. The tank is equipped with a pop valve, manual and automatic drain (standard brake models) valves. The manual drain is located on the DRY side of the tank. The pop valve and automatic drain valve are located on the WET side. The pop valve is designed to release pressure in the tank when the pressure exceeds 130 psi. Drain valves for the air tanks are located in the engine service center compartment. Four valves are used, one for each half of the air tank.

Two air tanks are used with the air over hydraulic brake system, a discharge line from the dry side of the first tank charges a second air tank. The discharge line uses an inline check valve to prevent back flow of compressed air. All air lines are color coded for identification.

Pneumatically operated items are divided into two categories: brakes and accessory air. Brakes have full use of supplied air pressure. Accessory air items, such as a stepwell cover, receive air through a pressure protection valve (PPV). The PPV will not allow compressed air flow until approximately 60 psi. In case of an air system problem, the pressure protection valve will leave a reserve air charge for braking. Pressure protection valves are installed for safety.

A low-pressure air switch connected to a warning lamp on the dash console monitors the air system. The lamp will illuminate when a low-pressure condition exists. Check the operation of the low air lamp when the air tank is drained.



**NOTE: The air tank(s) should be drained manually every 30 days. Open the manual drain until all air escapes. Leave valve(s) open an additional five minutes allowing excess moisture to drain.**



The air governor is located in the engine compartment and performs two functions. It regulates the air compressor to cut-in and cut-out, keeping the air system in the specified operating range of 105-120 psi then sends an air "purge" signal to the Air Dryer.

Cut-in pressure of approximately 105 psi is factory preset from the governor manufacturer and is not adjustable. Cut-out pressure is calibrated to 120 psi. When cut-out pressure is reached, the governor will send an air purge signal to the Air Dryer. This opens the purge port of the Air Dryer, expelling moisture. The purge action of the Air Dryer is identified by the short release of air at the rear of the motorhome.

## AIR GOVERNOR

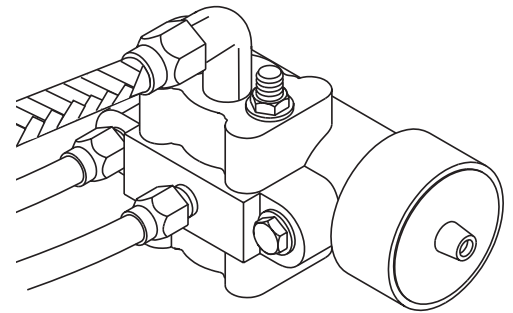

090310

The air dryer is located underneath the motorhome curbside rear. The air dryer removes moisture from the compressed air system. This is important because if air contains moisture it can freeze and prevent operation of brakes or other pneumatic operated items.

The air dryer has three functions: it (1) cools, (2) filters, and (3) dries air going through the motorhome's systems. If an excessive amount of water is present when performing the monthly air tank drain service, it may be an indication the filters inside the air dryer may need to be changed.

The following conditions can also cause water accumulation and should be considered before replacing filter:

- An outside air source has been used to charge system.
- In areas where a 30° range of temperature occurs in one day, small amounts of water can accumulate due to condensation. Under these conditions, moisture is normal and should not be considered a problem.

## AIR DRYER

Periodically check the two filters in the air dryer. Change, if necessary. The first filter is the spin-on desiccant filter. The second is the replaceable coalescing filter. Filters need to be checked or replaced every year depending on how often the vehicle is driven.

Remove coalescing filter to determine amount of contamination. If the filter looks black, filters need to be changed. If it is grey or white, the filters are fine. Whenever the filters need to be changed, make sure both the coalescing and desiccant filters are changed at same time. To remove filters unscrew desiccant filter and remove it. Next, reach in and remove coalescing filter.

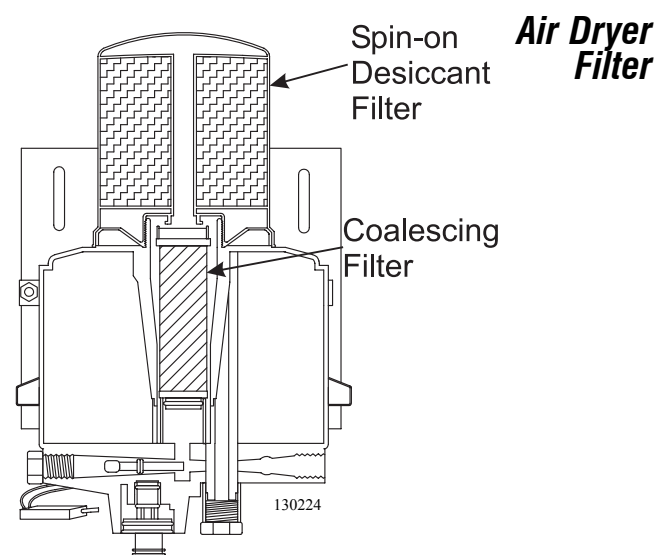

## AIR STORAGE TANKS

The air tank(s) should be manually drained once a month, or more, depending on operating conditions where humidity is high. Access the drain valves in the engine service center. Open the drain valves until all air is purged from tanks, allowing five extra minutes for moisture to be expelled. Remember to close the tank drain valves. Both air tanks have a pressure relief valve which are set to release at approximately 130 psi.

## AIR COUPLER - UNIVERSAL

Provided for convenience is a remote air supply coupler. This is located in the engine service center compartment. This female fitting will accept Type C 1/4" ID male air fittings. This auxiliary air fitting may be used to inflate tires, air mattresses or other pneumatic items.



**CAUTION: This fitting is not designed to charge the air system of the motorhome.**

### To use this feature:

- The fitting is located in the engine compartment service center.
- Using a firm grip, slide the locking collar back and insert the air hose fitting.
- Ensure the fitting is fully seated into the coupler before releasing the locking collar.

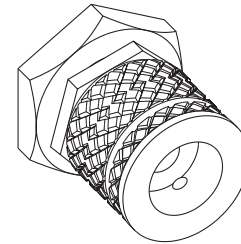

### To remove fitting:

- With a firm grip hold the air hose near the fitting to prevent recoil.
- Slide the locking collar back.

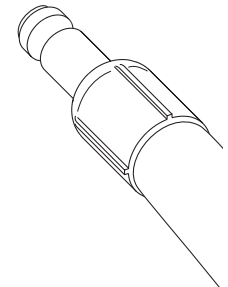

040458b



**NOTE: There are small air pressure restrictions in the pressure protection valve and tire stem valve. Due to this restriction, the maximum amount of tire pressure achieved when the system is used to fill a tire is approximately 95-105 psi with air system on the motorhome charged to 120 psi. Maximum outlet air pressure is achieved when the air system completes the fill cycle indicated by the purge cycle of the air dryer.**

## SUSPENSION AIR RIDE BAGS

Air ride springs are available in single, double and triple convolution types plus reversible sleeve models for virtually every conceivable heavy-duty vehicle suspension application.

1. **STUD:** Manufactured as a permanent part of bead plate assembly for maximum strength and durability. Used to attach spring to the vehicle's suspension.
2. **BEAD PLATE:** Crimped onto bellows at the factory for a durable design and maximum quality control. Allows 100% leak proof testing prior to shipment.
3. **BELLOWS:** "Air bag" includes four plies of material: an inner layer, two plies of cord-reinforced fabric and an outer cover. Natural rubber construction provides functional properties up to - 65° F.
4. **BUMPERS:** A solid rubber or engineered plastic device designed to prevent significant damage to the vehicle or its suspension in event of a sudden loss of air pressure in spring.
5. **PISTON:** Provides a lower mounting arrangement for air spring. Controls characteristics of spring under changing pressure loads.
6. **PISTON BOLT:** Attaches piston to bellows. Sometimes extended as a means of attaching spring to vehicle suspension.

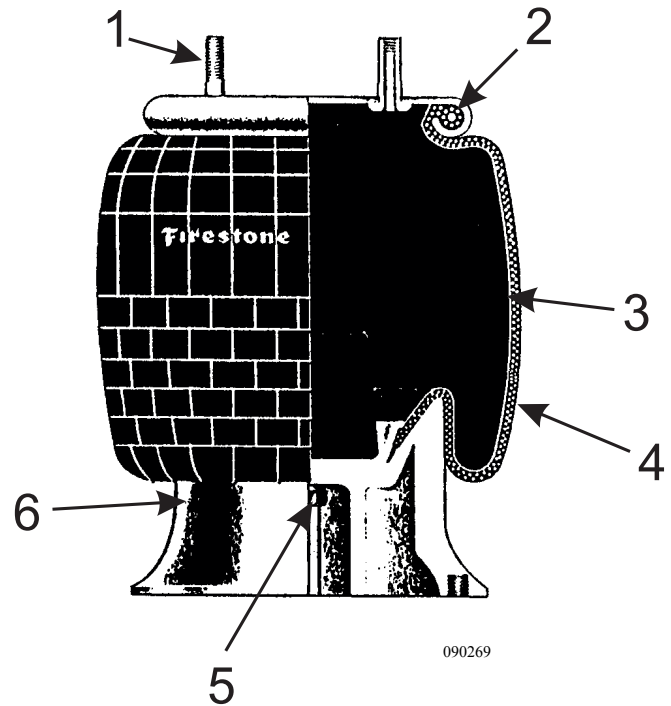

**Checklist -  
Air Bag Inspections**

Listed below are items that can be checked when the motorhome is in for periodic maintenance.



**NOTE: Never attempt to service the air suspension on a motorhome with the air bags inflated.**

- Inspect the O.D. of the air springs. Check for signs of irregular wear or heat cracking.
- Inspect the air lines to make sure contact doesn't exist between the air line and the O.D. of the air springs. Air lines can rub a hole in an air spring very quickly.
- Check to see that there is sufficient clearance around the complete circumference of the air spring while at its maximum diameter.
- Inspect the O.D. of piston for buildup of foreign materials. (On a reversible sleeve style air spring, the piston is the bottom component of the air spring.)
- The correct ride height should be maintained. All motorhomes with air springs have a specified ride height established by the manufacturer. This height should be maintained within  $\frac{1}{4}$  in. This dimension can be checked with the vehicle loaded or empty.
- The leveling valves (or height control valves) play a large part in ensuring that the total air spring system works as required. Clean, inspect and replace if necessary.
- Make sure to check shock absorbers for leaking hydraulic oil and worn or broken end connectors. If a broken shock is found, replace it immediately. The shock absorber will normally limit the rebound of an air spring and keep it from overextending.
- Check the tightness of all mounting hardware (nuts and bolts). If loose, tighten. Do not over-tighten.

**Cleaning:**

The approved cleaning method is to use soap and water, methyl alcohol, ethyl alcohol and isopropyl alcohol. Unapproved cleaning methods include all organic solvents, open flames, abrasives and direct pressurized steam cleaning.

**SHOCK ABSORBERS**

The shock absorber by definition is a hydraulic device used to dampen suspension/body movement. The road surface irregularities or roughness is compensated for by the shock absorber.

The Magnum raised rail chassis incorporates a "Gas Magnum" shock in the design of the exclusive, air glide suspension system. This shock absorber is a telescopic, monotubed unit filled with nitrogen gas and hydraulic oil. The result of the mixture is uninterrupted damping for the smallest of wheel deflection.

By design, a self-lubricating seal is used which will allow approximately 10% of the total oil capacity to pass onto the piston rod. The gradual process of oil loss does not affect the performance of the shock absorber during the service life. This process will be evident after a long period of service, by an oil film on the body of the shock absorber.

The appearance of a coating or film on the body or rod is called "Misting" and is completely normal. It is an indication that the shock is functioning normally.

The road holding, handling, balance and braking characteristics all can be contributed to the shock absorber. A visual check or inspection is recommended for obvious damage. The key check will be driving; any noticeable changes in the ride of the motorhome, a lean in the motorhome or excessive bouncing may be caused by a worn shock.

The operating conditions for which the shock absorber must endure will determine the life span.



090315

*Normal shock absorber appearance after a long service period.*

## SUSPENSION

The air suspension system uses air drawn from an air system to pressurize the air bags. The height control valve regulates the air pressure required for varying loads and maintains ride height. The suspension can provide a cushioned ride throughout the load range. It will also provide excellent stability from side to side and axle to axle, which helps equalize and control braking.

Each axle has two *Firestone* air bags and two *Monroe* shocks to provide the smoothest ride, best handling and top notch drivability. The suspension control arms bushing require no lubrication. The suspension ride height is preset and will automatically maintain proper ride height throughout the entire load range. Improper ride height adjustment could result in a poor ride or damage to the suspension, thus leading to erratic coach handling. The air bags, shock absorbers, control valves, and link assemblies should be visually checked as part of pre-trip and safety inspections. This should be done on a level surface, allowing two minutes after the low air lamp extinguishes. Items that can be checked when the motorhome is in for periodic maintenance are listed below.



**NOTE: Never attempt to service the air suspension on a motorhome with the air bags inflated.**

- Inspect the O.D. of the air springs. Check for signs of irregular wear or heat cracking.
- Inspect the air lines to make sure contact does not exist between the air line and the O.D. of the air springs. Air lines can rub a hole in an air spring very quickly.
- Check for sufficient clearance around the complete circumference of the air spring while at its maximum diameter.
- Inspect the O.D. of the piston for buildup of foreign materials. (On a reversible sleeve style air spring, the piston is the bottom component of the air spring.)
- Correct ride height should be maintained. The specified ride height has been established and set at the factory. This measurement can be checked with the vehicle loaded or empty.
- Leveling valves (or height control valves) play a large part in ensuring that the total air spring system works as required. Clean, inspect and replace if necessary.
- Check shock absorbers for leaking hydraulic oil and a worn or broken end connector. If a broken shock is found, replace it immediately. The shock absorber will normally limit the rebound of an air spring and keep it from overextending.
- Check the tightness of all mounting hardware (nuts and bolts). If loose, tighten. Do not over-tighten.

## ALIGNMENT SPECIFICATIONS

The correct wheel alignment promotes longer tire wear and ease of handling while minimizing the strain on the steering system and the axle components.

### Camber:

Camber, as shown, is vertical tilt of wheel as viewed from the front of the vehicle. This is machined into the axle when manufactured and is not adjustable.

- “**Positive**” camber is an outward tilt of the wheel at the top.
- “**Negative**” camber is an inward tilt of the wheel at the top.

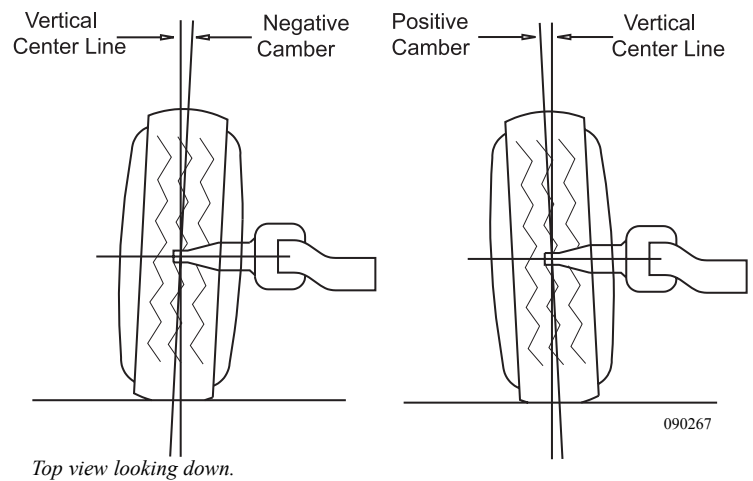

### Toe Setting:

The toe setting represents different distances between the front and rear of the tires (measured at the vertical center line of the tires).

Toe-in occurs when the tire front distance is less than the tire rear distance.

Toe-out occurs when the tire front distance is greater than the tire rear distance.

Wheels are generally set with initial toe-in. As the vehicle operates tires tend toward a toe-out condition. By starting with an initial toe-in setting, a desirable “near zero toe-in” can be achieved when the vehicle is in motion.

Incorrect toe settings, where toed-in or toed-out, can have a significant affect on tire wear. The toe setting is adjusted by lengthening or shortening the cross tube.

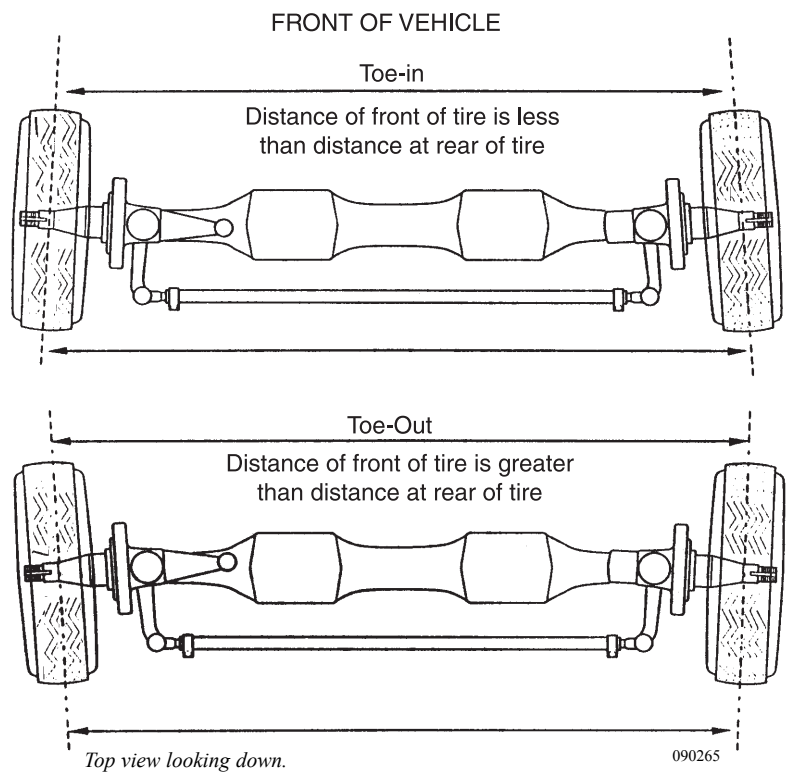

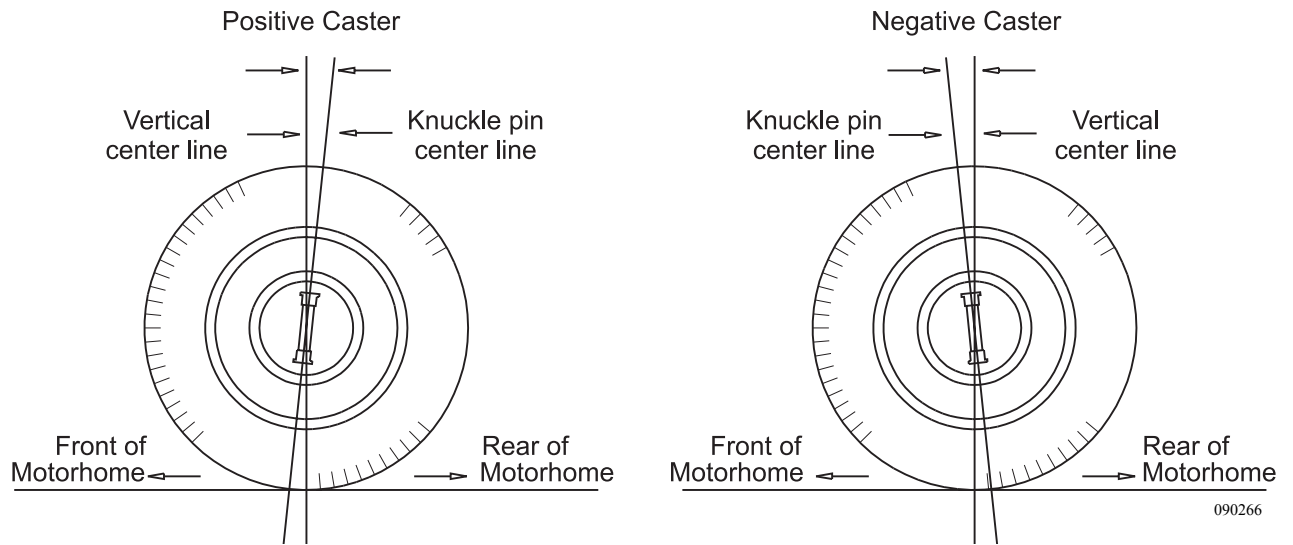

**Caster Adjustments:**

Caster is the fore and aft tilt (toward the front or rear of the motorhome) of the steering kingpin as viewed from the side of the motorhome.

“Positive” caster is the tilt of the top end of the kingpin toward the rear of the motorhome.

“Negative” caster is the tilt of the top end of the kingpin toward the front of the motorhome.

A caster angle more positive than specified may result in excessive steering effort and/or shimmy. An angle less positive may result in vehicle wander or poor steering return to center. The caster angle is determined by the installed position of the steer axle.

FRONT	SPEC.	TOL.
Left Camber	-0.00°	0.41°
Right Camber	-0.24°	0.41°
Cross Camber	---	0.25°
Caster	3.50°	1.00°
Cross Caster	-0.00°	1.00°
Total Toe	0.03°	0.12°



**BRAKE SYSTEMS**

The chassis incorporates four separate braking systems: The Primary Brake System, the Parking/Emergency Brake System, the Antilock Braking System (ABS) and the Engine (Exhaust) Braking System. The Primary Brake System uses air pressure to assist hydraulic brake actuation. This system includes dual air diaphragm assemblies to operate each master cylinder assembly. Brake operation relies primarily on the amount of air pressure in the system, however in the event of air loss, the brakes will remain operational with a greatly increased stopping distance. If air pressure falls below 35 psi, the park brake will automatically engage.

The parking brake system is activated when the push-pull control knob (located on the drivers left console panel) is pulled. When the knob is pushed, the brake is released. Prior to driving, allow time for the air compressor to build up sufficient air to shut off the air warning lamp.

**BRAKE - PARKING & EMERGENCY SYSTEMS**

**NOTE: A wooden block placed under the knob will prevent accidental brake release.**

Park Brake.eps

The Hydraulic Antilock Braking System is an electronic wheel speed monitoring and control system. The Electronic Control Unit (ECU) receives and processes signals sent from the wheel sensors located on each of the wheels. The ECU will process the signals and generate the commands to the solenoid control valves housed in the Modulator Assembly used to control the brake pressure. This process occurs when the wheels begin to lock. The rapid valve operations may even be noticed in the brake pedal.

**BRAKES - ABS SYSTEM (Anti-lock Brakes)**

The ABS indicator light located on the dash will alert the driver to possible system faults and is used by service personnel to assist in troubleshooting. In the event the ABS indicator light remains illuminated, normal braking is not affected. However, the ABS system may not function correctly in a panic stop. It is recommended to drive with caution and obtain service on the ABS system as soon as possible.

The exhaust brake, located in the exhaust system of the engine, is designed to supplement the primary braking system. Various features and benefits are obtained with application of the exhaust brake. Attached directly to the engine turbocharger, the exhaust brake is activated when the Exhaust Brake switch at the drivers console is switched "ON" and the throttle is "RELEASED." Turning the Exhaust Brake switch ON will not disengage the cruise control. Tapping or applying the service brake pedal will disengage the cruise control.

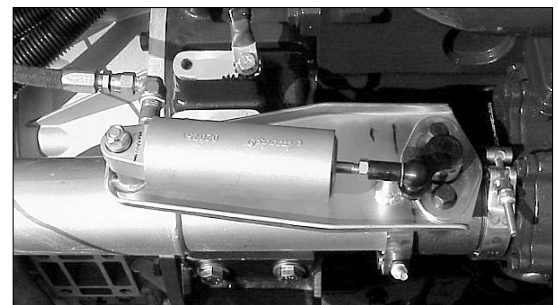
**BRAKES - EXHAUST BRAKE SYSTEM**

Exhaust Brake.

jacobs brake.eps

The amount of braking power developed, which is applied to the drive wheels only, is relative to the engine speed (RPM). When the exhaust brake activates, a butterfly plate inside the exhaust brake closes restricting the flow of exhaust gases increasing back pressure in the engine resulting in powerful engine braking action. This braking action reduces the use of the service brake and results in service brake conservation. The exhaust brake is not a substitute for the service brake and cannot stop the motorhome completely. It can, however, be used continuously on steep downhill grades or a long freeway off ramp.

When the exhaust brake is activated, the sound of the engine may vary and the slowing effect may or may not be felt in high gear. Once deactivated, normal throttle response with a slight change in RPM should occur. When the exhaust brake is activated going down a hill, the exhaust brake will help control road speed and the transmission automatically downshifts to the next lower gear. Downshifting will automatically continue from high gear down to second gear. Certain road conditions and engine speeds may require the transmission be manually down shifted in order to generate adequate engine RPM and increase the engine braking effect. Use of the exhaust brake system allows the engine temperature to drop while going downhill. The exhaust brake should be turned off prior to starting the engine and when the engine is left idling for long periods of time.



**CAUTION: Use of the exhaust brake on wet and slippery surfaces can result in over braking and loss of traction.**

---

### **Exhaust Brake Maintenance**

The exhaust brake system, used routinely at normal exhaust operating temperatures, is virtually maintenance free. Some contributing causes which can result in failures with the exhaust brake include moisture, dirt, carbon and improper usage.

Starting the engine and idling for short periods of time is not recommended. Moisture is created within the engine and the exhaust system during cold startups. When normal operating temperatures are not obtained, moisture may get trapped in the valve housing resulting in rust, leading to insufficient operation of the exhaust brake.

Some problems that may be encountered with the exhaust brake include, but are not limited to, will not activate or deactivate, intermittent on/off operations or actuates with the switch off. These are commonly related to electrical symptoms. Slow operations or delays in operations, as well as limited performance, are mechanical symptoms. Refer these problems to the dealer for diagnosis.

**BRAKE  
MAINTENANCE &  
TROUBLESHOOTING**

The most critical part of the service brake system is bleeding the system. Prior to bleeding the system, ensure all hose clamps, line connector and fittings are tight enough to prevent air from entering the system or fluid from leaking. The hydraulic brake system must be free of air to function properly. When bleeding, check the fluid level in both the power steering reservoir and master cylinder. If power steering fluid is noticed in the master cylinder, End Cap service on the power booster assembly can correct the leak. The Hydro-Max system should be bled prior to the brake system. Applying the brakes will cycle the pump and purge any air from the electric pump system.



**NOTE: The power steering system and the hydraulic portion of the brake system are two separate hydraulic systems. The fluids are not compatible and should not be mixed. Mixing of fluids will damage the systems and reduce service life.**



**NOTE: Do not attempt to move the motorhome in the event any line is disconnected, component removed or part of the hydraulic brake system is opened. There will be no braking capabilities until the affected system is bled.**

The engine will need to be started to bleed the booster. When started, applying the brakes two to three times will purge the air from the booster. Inspect fluid levels, add fluid as required.



**WARNING: Brake lining may contain asbestos material and should only be serviced by qualified service technicians who are trained in the appropriate precautionary procedures.**

The brake system on the motorhome is designed to accommodate the weight of the vehicle and towing loads. The air over hydraulic brake system is different from the conventional automotive hydraulic brake system and should be treated differently.

When operating a vehicle equipped with air brakes, considerations need to be given to stopping distances and air system pressures. The heavier the vehicle, the greater the kinetic energy. The motorhome has longer stopping distances than a car. Each brake application uses air from the air system. Engine speed is directly proportional to how fast the air system is replenished. Prepare for downhill grades. Grades are generally posted in percentages. It may be necessary to select a lower gear. Use the exhaust brake.

When making brake applications, use individual short applications down long hills rather than "riding" the brakes. This will extend the life of the brake linings. Avoid overheating the brakes. Hot brakes have less stopping power. When maneuvering the motorhome around in small areas or backing into spaces, several individual brake applications might be made. Plan when parking to make it easier on yourself. When preparing to back into a space, maneuver the motorhome so it is aligned with the parking slot before backing up.

**BRAKES  
- AIR OVER  
HYDRAULIC**

Should a low air condition arise while the vehicle is under operation a dash warning light will illuminate alerting the operator of the situation. This warning occurs at approximately 60 to 65 psi (pounds per square inch).

A simple mechanical explanation of what occurs when a brake application is made is as follows: The air over hydraulic system uses air from the air tank to operate two air brake chambers. The air brake chambers operate two separate hydraulic master cylinders. The rest of the brake system is hydraulic. One master cylinder operates the front brakes; the other master cylinder operates the rear brakes.

---

### **Bleeding the System**

It is important a supply of clean brake fluid be used during bleeding. Also, maintain the proper fluid level in the reservoir during bleeding. The sequence for opening the bleeder valves is curbside rear, roadside rear, curbside front and roadside front. A clear plastic tube inserted over the bleeder valve can aide in viewing air. Place the other end of the plastic tube in a container to catch the drain. When the valve is opened, observe the flow of fluid. Once a steady flow of fluid is present, close the bleeder valve. Check the fluid level in the master cylinder and repeat the process for the remaining calipers.

Flushing the system requires that the bleeder valve be left open until the fluid appears clear and uncontaminated. The system should be flushed whenever any repair has been performed, ensuring clean and uncontaminated fluid in the system.



**NOTE: Do not reuse brake fluid which has been drained as the fluid may be contaminated.**

Tires, suspension, wheel alignment and shocks can affect braking performance and should be inspected prior to checking the braking system. Some problems and repairs are listed below:

- Pedal fade is a good indication of leaks in the system. Inspect and repair leaks.
- Sluggish brake response indicates air has been introduced into the system. Bleed the brake system.
- Excessive pedal travel or excessive pedal effort relates to booster and master cylinder.
- Booster doesn't function properly in power or back-up mode. Repair the booster and pump assembly.
- Booster works only in the back up mode. Repair the booster assembly.
- Booster works only in the power mode. Repair the back-up pump.
- Dragging, grabbing, squealing or pulling brakes require servicing pads and calipers.

All front axles use oil to lubricate the wheel bearings. Inspect the oil level before every trip or every 5,000 miles. The oil is drained and refilled without removing the wheel end assembly. Remove the hubcap to access the bearing cover and drain plug.

## **FRONT AXLE (Oil Filled Bearings)**

### **To inspect the oil level:**

- Remove the chrome hubcap.
- Locate the full and add mark on the outside of the clear plastic cover.
- If the lubricant level is low, add the recommended fluid until full.

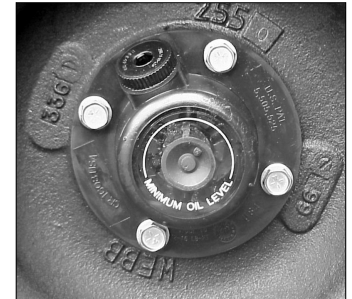

The recommended oil change interval is based on the operating conditions, speeds and loads. Limited service applications may allow the recommended interval to be increased. Severe applications may require the recommended interval to be reduced. For more information, contact a Westport service representative.

### **Recommended Interval Change:**

- Change the fluid whenever the seals are replaced, the brakes are relined or at 30,000 miles (48,000km). However, check the lubricant twice a year (spring and fall) for contamination. Change as needed.
- If yearly mileage is less than 30,000 miles, change it twice a year (spring and fall).

### **Lubricant Type:**

- Standard 90 wt. API GL-5. Lubricant temperature must never exceed 250°F (+121°C).

### **To Drain:**

- Place a suitable container below the bearing cover and remove the drain plug. If the cover does not have a drain plug, remove the screws retaining the cover plate to drain the lubricant.
- Replace plug or cover plate and fill bearing assembly with the recommended lubricant.

The three point leveling system features a multiple warning system with flashing lights and a bong alarm to alert you of the jack position. The system also features a remote control location from the driver seat. The torsion stress is significantly reduced during proper operating procedures. Damage resulting from improper procedures can range from windshield damage to entry doors jamming.

## **LEVELING SYSTEM - Hydraulic Leveling**

The model 22.5A J-II leveling system pump is located next to the battery compartment. The valve assembly manifold is mounted on the the pump motor, providing easy access to the manual retract valves. The system is designed to be self bleeding in the event any component of the hydraulics has been removed or repaired. Fully extend and retract each jack twice. The remote rocker switches will operate with a minimum of 7.5 Volt DC. Optimum requirements for operating the system are voltages above 9.6 Volt DC.



**NOTE: The leveling system jacks are not designed for use in changing tires. This can cause problems with the suspension system, frame alignment and/or cause damage to the windshield.**

### Manual Leveling System

When manually operating the leveling system, always lower the front jack first. The front jack acts as a pivot point for the chassis and reduces torsion stress on the body of the motorhome.



**NOTE: In the event the front of the motorhome is high and does not require elevating, it will be necessary to raise front of motorhome a minimum of ½ inch to allow jacks to act as a pivot point.**

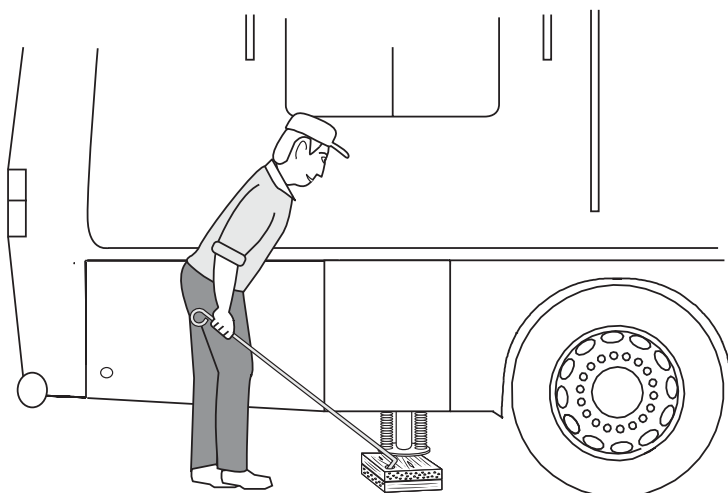

020185

The leveling system was designed to reduce site selection problems. If possible, park the motorhome with the front facing downhill. If the ground is soft, place two pieces of 1' x 1' x ¾" plywood, stapled together, under the foot of each jack pad to prevent sinking. Drill a hole in one end of the block, and use the awning hook to slide it under the jack pad.

The front jack will be the pivot point for the chassis and is always lowered first. This reduces the torsion stress on the body of the motorhome. The Bong alarm will activate when any jack is extended more than 2" to 6" from fully retracted position and will indicate low fluid level for the pump motor. The Bong alarm may momentarily activate when driving over rough roads, or negotiating curves and corners. Usually this indicates low fluid level.

- Place the **gear selector** in **NEUTRAL**.
- Apply the parking brake.
- Turn the **ignition switch** to the **ON** position.
- Switch the **main jack control power switch ON**.
- To extend a particular jack, push the appropriate rocker switch to extend position and hold it until the desired extension is reached.
- To retract a particular jack, simply push the rocker switch to the **retract** position and hold until the desired retraction is reached.
- All jacks may be retracted by selecting the **ALL** position on the **power switch**.
- Turn **OFF** the switch labeled **POWER** on the **jack control panel**.
- Turn **OFF** the **ignition switch**.

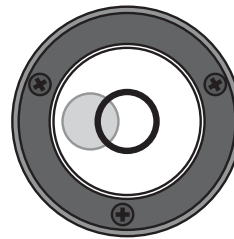
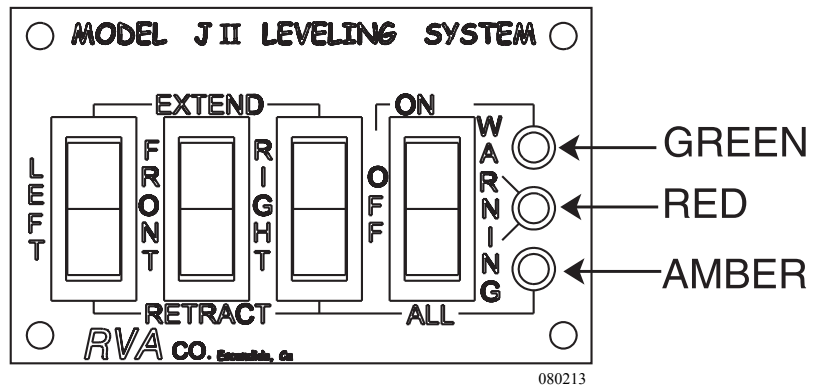

**NOTE: Do not move the motorhome until the jacks are fully retracted. A visual check of the jacks is recommended to ensure full retraction. Do not rely solely on the lights and alarms.**

In the event of mechanical or electrical failure that would prevent the leveling jacks from being automatically retracted, the motorhome is equipped with manual emergency retract valves. These valves are located inside the front generator access. The manual system will release fluid under pressure in each jack and allow fluid to return to the reservoir. The jacks will then retract.

### **Manual Retract Valves**

To operate the manual system, turn all three valves counterclockwise until they stop. Once the jacks are fully retracted, rotate all the valves fully clockwise. In the event one of the jacks is not holding pressure, check to make sure all valves are fully closed.

Occasionally, while the jacks are fully extended, wipe dirt from the jack rod. This will help lengthen the life of the jacks. This can vary from the amount and type of usage of the jacks. **WD-40** will serve as a solvent as well as a lubricant. Occasional oil or grease on the extended jack ram is normal and aids in the lubrication of the ram. It helps to learn the sound of the normal pumping and gurgling sounds of the pump when it is low on fluid.

**Adding Fluid:**

1. Use **Dexron III**<sup>®</sup> automatic transmission fluid.
2. Extend any jack six inches from the full retracted position. All other jacks should be fully retracted.
3. Unscrew the reservoir cap from the top of the pump.
4. Turn the ignition switch to the **ON** position. Turn the rocker switch to **ON**. Open the window so the bong alarm is audible from outside the motorhome. Slowly fill the reservoir with fluid until the bong alarm stops sounding.
5. Replace the reservoir cap.
6. Turn the ignition switch and the remote panel **OFF**.

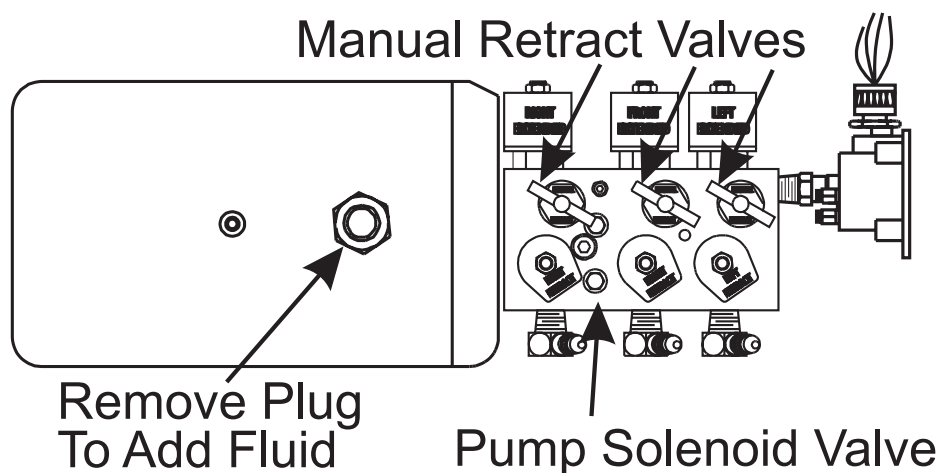

020027modified

---

**ENGINE -  
GENERAL  
INFORMATION**

The diesel engine operates differently from the conventional gasoline engine. Gasoline engines control engine speed using a butterfly throttle plate controlling air/fuel mixture inlet flow. As the throttle plate opens, vacuum created by the piston velocity draws the metered fuel/air charge into the combustion chamber, then ignites from a controlled electric ignition source. Closing the throttle plate limits the fuel/air supply, slowing engine speed, increasing intake manifold vacuum.



The diesel engine in the motorhome controls engine speed by varying fuel supply only. No throttle plates are used. An exhaust driven turbine system (turbocharger) compresses the fresh air supply into the engine. The fuel is injected under pressure into the combustion chamber. Ignition of fuel/air charge occurs from heat generated by rapid high compression. The turbo boost gauge registers amount of intake manifold compression measured in lbs./in<sup>2</sup>. Therefore, no intake manifold vacuum exists.

Diesel engine RPM (revolutions per minute) operating speeds are generally much lower than that of the gasoline engine. Peak torque and horsepower output values occur at much lower engine speeds. Idle speeds between the two engine types are similar, however maximum engine speeds are quite different. The gasoline engine generally is not regulated to a maximum engine speed. The maximum engine speed on a diesel engine is controlled by an engine speed governor set by the engine manufacturer.



**WARNING: Do not operate a diesel engine where there are or can be combustible vapors. Vapors can be drawn through air intake system and cause engine acceleration and over-speeding, resulting in fire, explosion and extensive property damage. Numerous safety devices are available, such as air intake shutoff devices, to minimize risk of over-speeding where an engine (due to its application) might operate in a combustible environment, such as fuel spills or gas leaks. Equipment owner and operator is responsible for safe operation of engine. Consult your engine authorized repair location for future information.**

The maintenance guidelines found in the Cummins Operation & Maintenance manual is recommended for the engine. When followed, it will help with a longer life, better performance and more cost efficient operations. A good maintenance schedule begins with a daily awareness of the engine and its various systems.

The engine is equipped with an intake manifold grid heater. The grid heater helps engine starting in cold weather. Intake manifold air temperature is monitored by the Electronic Control Module on the engine. If intake manifold temperature is below specified level (approximately 40° F.) manifold grid heater will be activated. Grid heater activation is indicated by the **WAIT TO START** indicator lamp.



**WARNING: Use of ether starting fluids may cause an explosion upon grid heater activation.**

---

## ENGINE

## STARTING PROCEDURE

With throttle in idle position, turn ignition to the **ON** position allowing **WAIT TO START** lamp to extinguish. Turn key to the **START** position. When the engine starts the grid heater will again energize for a time period determined by the intake air temperature and the fuel temperature. Allow engine to idle with no load for three to five minutes. The engine coolant temperature should be up to normal operating range (140° F/60 ° C to 212° F/100° C) before operating engine under full throttle.



**NOTE: It is not recommended to idle the engine for long periods of time. This will simply waste fuel and annoy neighbors. Consistent periods of long idle may cause damage to the engine.**

## STARTING PROCEDURE - COLD WEATHER

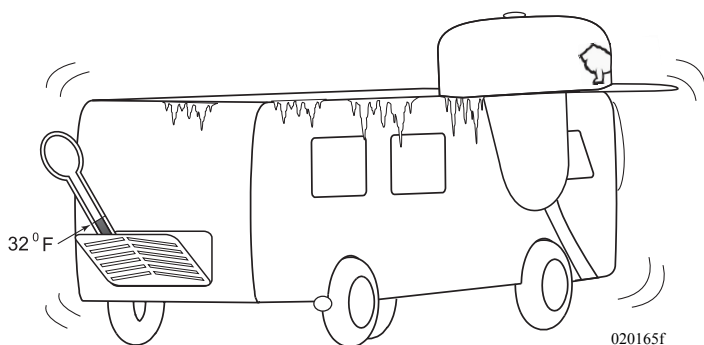

The engine block heater may need to be plugged in two to three hours prior to starting. The engine block heater is rated at 1,000 watts ISC, 110 Volts AC and requires the motorhome be plugged into shore power or have the generator running. It is not necessary to leave the block heater plugged in for long periods of time. The block heater requires about 7.5 to 10 Amps to operate.

## OIL RECOMMENDATIONS (Engine)

The maintenance guidelines found in the Cummins Operation & Maintenance Manual is recommended for the engine. When followed it will help with a longer life, better performance and more cost efficient operations. A good maintenance schedule begins with a daily awareness of the engine and its various systems.

A high grade 15W-40 multiviscosity heavy duty lubricating oil meeting Cummins Engineering Specification CES 20071 or CES 20076, American Petroleum Institute (API) specification CH-4 which can be used as an alternative to CES 20071 is recommended. Lubricating oils meeting API CG-4 specifications may be used at a reduced drain interval. The engine uses Pennzoil 15W-40 heavy duty engine lubricating oil that meets Cummins specifications. A critical factor in maintaining engine performance and durability is the use of high grade multigrade lubricating oil and strict adherence to the maintenance service intervals.

A straight weight or monograde lubricating oil is not recommended. Shortened drain intervals may be required as determined by a close monitoring of the lubricating oil condition by means of a oil sampling program. The use of oil analysis to extend drain interval is not recommended. There are numerous variables which is the basis of the recommendation.

Synthetic oils API category III specifications are recommended for extreme cold temperatures only.

Low viscosity oils, used for winter operations, will aid in starting. Synthetic oils, or oil with adequate low temperature properties used for Arctic operations where the engine cannot be kept warm when shut down, will aid in starting.

The use of synthetic oils should not be used to extend drain intervals. Extended oil change intervals can decrease engine life and possibly affect the engine warranty.

Oil additives should not be used unless the oil supplier or oil manufacturer has been consulted and provided positive evidence or data establishing satisfactory performance in the engine.



**NOTE: The engine does not require a “break-in” procedure.**

#### **Function of Engine Oil:**

If a lubricating oil is to work in an engine it must be capable to perform various functions. Lubrication of the moving parts is the primary function. The lubricating oil should be able to form a film between metal surfaces preventing metal to metal contact and reducing friction. When you have a metal to metal contact, friction heat is generated. Welding of the part can occur and metal transfer will result in scuffing or seizing. The film of oil contacting the surfaces will provide cushioning and shock dampening as well.

Cleaning is another function. The oil should perform as a cleaner in the engine by flushing contaminants from critical components. These contaminants should be removed in the filtration system or during the course of an oil change. Oil will provide a protective barrier to prevent corrosion of non-like metals.

Internal components of the engine require cooling. The primary coolant system cannot provide this cooling. Oil will transfer heat by contacting the various components then transferring to the primary cooling system at the oil cooler. The uneven surfaces are filled to react as a combustion seal within the cylinder liner and other internal components.

#### **Synthetic Engine Oil:**

In extreme environments, where ambient temperatures can be as low as 45° C (-50° F), a petroleum based oil will not perform satisfactorily in diesel engines. Synthetic oils were developed for these type applications. These synthetic oils are blend from ester and/or hydrocarbon based oils. These base oils are produced by chemically reacting lower molecular weight materials to manufacture lubricants of desired properties. All synthetic based oils must meet the API category III classifications and SAE viscosity grades. Synthetic oils and petroleum-based oils should never be mixed.

**Viscosity:**

Viscosity is simply a measure of resistance of molecule layers moving relative to an adjacent layer. All fluid viscosity is affected by temperature. A multigrade lubricating oil tends to be less sensitive to temperature changes due to formulation. Lubricating oils are generally selected for use with viscosities appropriate for the expected operating temperature. The correct selection of a lubricating oil of correct viscosity is critical for optimum performance. Some effects of incorrect viscosity when the oil is too thick range from difficulty in starting, to increasing fuel consumption and reducing power output. When the oil is too thin, oil consumption is increased as well as wear from the metal to metal contact. This will also increase engine noise.

Low temperature viscosity specifications are identified by a “W” (winter). High temperature viscosity that meets the 100° C (212° F) requirements have no suffix. When a lubricating oil meets both high and low temperature requirements they are classified as multi-viscosity or multigrade.

**Routine Maintenance Recommendations:**

1. Check oil level daily.
2. Replace oil filter at every oil drain interval.
3. Cummins Engine Company, Inc. recommends the use of high quality, API (American Petroleum Institute) licensed CH-4 or CES20071, 15W-40, multiviscosity oil or premium oil.
4. The recommended oil drain interval is defined by the API oil performance classification and the engine duty cycle. Refer to the Cummins Operation & Maintenance Manual for complete details.

---

**Oil  
Recommendations -  
Cold Weather**

It is possible to operate diesel engines in extremely cold environments. The engine should be properly prepared and maintained. The correct lubricants, fuels and coolant **MUST** be used for the cold weather range for which the motorhome is being operated. Cold weather operation can be defined in two categories: **Winter** and **Arctic**.

**WINTER (32° to -25° F) (0° to -32° C):** Use a 50% antifreeze to 50% water coolant mixture, use multi-viscosity oil meeting Cummins specifications and fuel to have maximum cloud pour points 10° F (6° C) lower than the ambient temperature in which the motorhome operates.

**ARCTIC (-25° to -65° F) (-32° to -52° C):** Use a 60% antifreeze to 40% water coolant mixture. Use oil meeting Cummins specifications and fuel to have maximum cloud pour points 10° F (6° C) lower than the ambient temperature in which the motorhome operates.



**Refer to the Operations & Maintenance Manual for more detailed information.**

General guidelines for shutting the engine down are fairly simplistic. Allow the engine to idle three to five minutes after a full load operation. This allows adequate cool down of pistons, cylinders, bearings and turbocharger components. Under normal driving conditions, exiting the highway is generally lighter engine operation and the need for the three to five minutes is not necessary.

## ENGINE SHUTDOWN

When the motorhome has been sitting for extended periods, 30 days or more, verify all the fluid levels are correct. Follow the normal starting procedures. If the oil pressure gauge does not register within 15 seconds, shut off the engine immediately to avoid damage. Consult the Cummins Operation & Maintenance Manual for guidelines on troubleshooting low oil pressure, or contact a qualified service technician. Allow the engine to idle for three to five minutes before operating under a load.

## ENGINE SHUTDOWN - Extended

A fully formulated antifreeze or coolant containing a precharge of Supplemental Coolant Additives (SCA) is recommended. The use of either will significantly simplify coolant system maintenance. The difference between a fully formatted antifreeze and a fully formatted coolant is the percentage of water. Both contain balance amounts of antifreeze, SCA, buffering compounds and a percentage of good clean quality water. The antifreeze of coolant must meet ethylene glycol or propylene glycol recommendations. A good clean quality water in a 50/50 ratio (40 to 60% working range) mixed with fully formatted antifreeze will provide protection from -34° F to 228° F. The 50/50 mix ratio must be premixed prior to being put in the system. Placing antifreeze and water in the cooling system is not recommended. Consult the Cummins Operation & Maintenance Manual for more details.

## COOLANT

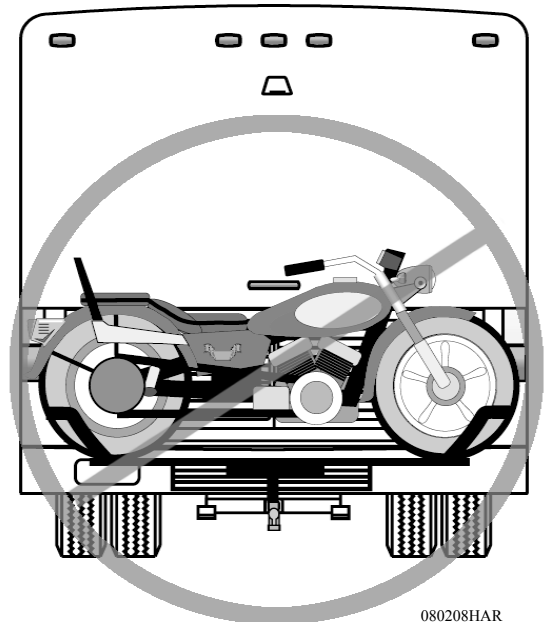

080208HAR



**NOTE: An over concentration of antifreeze, or the use of high silicate antifreeze, can cause damage to the coolant system and engine. Antifreeze is essential in every climate.**



**NOTE: Any item on the back of the motorhome which blocks the grill opening or changes the air flow may cause an over-heating condition under some circumstances.**

The coolant fluid freeze point should be checked with every oil change interval at 15,000 miles, 500 hours or six months, whichever comes first. Also change the coolant filter at the same interval unless SCA concentration is over three units. The coolant should be drained and flushed at 6,000 hours or two years of service, whichever comes first.

### Engine Coolant Reservoir:

A “see-through” plastic reservoir, similar to the familiar windshield washer jar, is connected to the radiator by a hose. As the motorhome is driven, coolant is heated and expands. A portion of fluid displaced by this expansion flows from the radiator into the reservoir tank. When the engine is stopped, and coolant cools and contracts, displaced coolant is drawn back in the radiator by a vacuum. Thus, the radiator is kept filled with coolant to the desired level at all times resulting in increased cooling efficiency. The coolant level should be at or above the appropriate mark on the reservoir tank when the system is cold.



**CAUTION: To avoid scalding hot steam or coolant from being released from the engine cooling system, never remove the radiator cap while the engine is running or hot. Failure to follow this warning may result in damage to the engine’s cooling system and possibly cause severe personal injury.**

- Check the coolant level daily or when refueling.
- Drain and flush the coolant system every 60,000 miles or two years, and refill with a heavy-duty coolant (50/50 mix of water and anti-freeze).
- If the coolant is below the **MIN** mark, the low coolant alarm will sound and the low coolant light will appear on the dash. Stop and check for coolant loss before driving.
- The coolant level to remain between the **MAX** and **MIN** level in the reservoir.

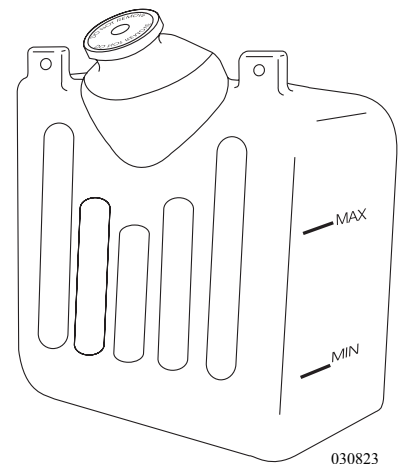

*The coolant capacity, when changing the antifreeze, is approximately 1½ gallons.*

### Routine Maintenance Recommendations:

1. Check the SCA concentration level every 15,000 miles/6 months.
2. Change the coolant filter every 15,000 miles/6 months.
3. Drain and flush the system every 240,000 miles/2 years, and refill with a heavy-duty coolant (50/50 mix of water and antifreeze).
4. Always use antifreeze. In addition to freeze protection, antifreeze is essential for overheat and corrosion protection.
5. The supplemental coolant additive (SCA) is required.
6. Freeze point should be measured every 15,000 miles/6 months.

Fully formulated products contain SCA and are required to protect the cooling system from fouling, solder blooming and general corrosion. The cooling filter is required to protect the coolant system from abrasive materials, debris and precipitated coolant additives.

Supplement coolant additives, or equivalent, are used to prevent liner pitting, corrosion and scale deposits in the cooling system. Use the correct Fleetguard coolant filter to maintain the recommended SCA concentration in the system. Maintain the correct concentration by changing the service filter at each oil drain interval.

## Coolant - Additive (SCA)

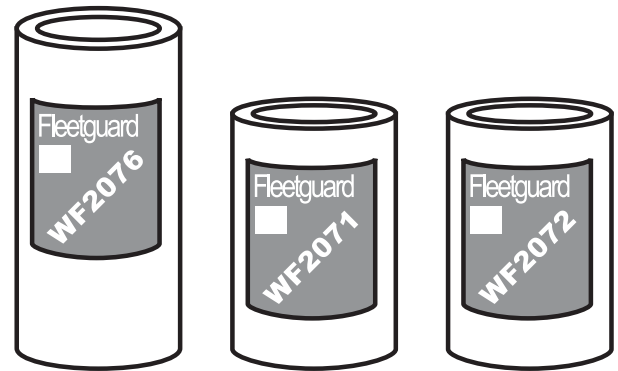

090331



**NOTE: The correct filter is determined by the total cooling system capacity and oil drain interval. Refer to the Coolant Capacity Specifications in this section.**



**CAUTION: Insufficient concentration of the coolant additives will result in liner pitting and engine failure. The SCA concentration must not fall below 1.2 units or exceed 3 units per gallon of cooling system capacity.**

Use the correct Fleetguard coolant filter to maintain the recommended SCA concentration in the system. Maintain the correct concentration by changing the service coolant filter at each oil drain interval. The oil pressure gauge, temperature gauge, warning lamps and other safety lamps should be checked daily to ensure proper operations.

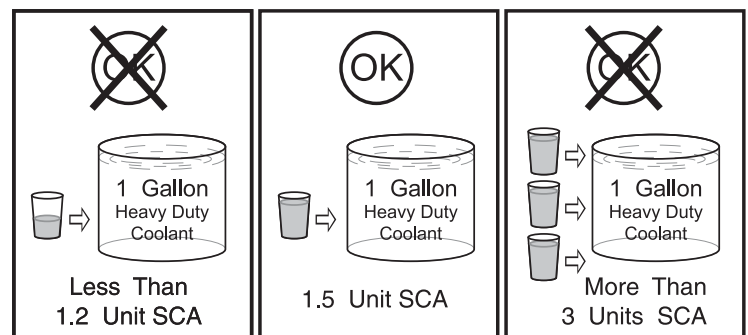

090331



**NOTE: The correct filter is determined by the total cooling system capacity. If you have any questions refer to the Cummins manual.**

Rotten, swollen and worn hoses, as well as loose connections, are frequent causes of coolant system problems. Overheating can be caused by a collapsed hose or a clog caused by rubber shedding from a rotten hose. Replace any hose found to be cracked, swollen or damaged. Connections should be inspected periodically and hose clamps tightened.

## Coolant Hoses

## Coolant System - Thawing

If the coolant system becomes frozen solid, place the motorhome in a warm area until the ice is completely thawed. At this point the motorhome must be towed. If the engine is operated when the cooling system is frozen it will result in engine overheating due to insufficient coolant.

Once thawed, check engine, radiator and related components for damage caused by expansion of frozen coolant.

If the engine is overheated, never pour cold coolant into a hot engine. The sudden change in temperature may crack the cylinder head or block. If the engine is hot, fill slowly to prevent rapid cooling and distortion of engine castings.

## TRANSMISSION - Shift Selector

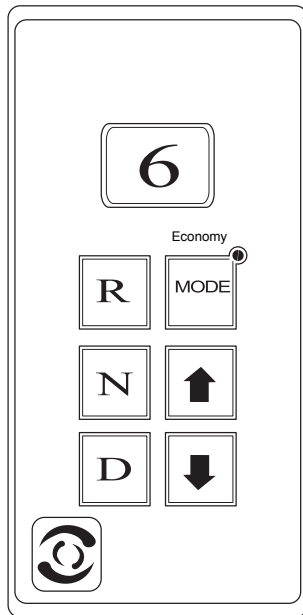

trans shifter w mode light.eps

The Allison World transmission incorporates the World Transmission Electronic Control (WTEC) system. The system is comprised of five major components connected by a wiring harness: the electronic control unit (ECU), engine throttle position sensor, three speed sensors, remote shift selector (key-pad) and the control module. The ECU processes information received from the throttle position sensor, speed sensor, pressure switch and shift selector to activate solenoids on the control module in the transmission. The solenoids control oncoming and off going clutch pressure to provide closed loop shift control. This is accomplished by matching transmission and engine RPM during a shift to establish a desired shift profile within the ECU.

The system is monitored for the first 30 seconds of each engine start. This is referred to as “autodetect.” Autodetect searches for presence of data inputs of transmission components. The autodetect enables the ECU functions and diagnostics to respond to items that are detected.

Another feature of the transmission is the ability to “learn” or “adapt.” The electronic control system optimizes shift quality by using “Adaptive Shifting.” A wide variety of varied shift conditions is required before optimizing shift quality. Generally, five typical shifts of a consistent shift type is needed to optimize shift quality.

The range selection is accomplished via the remote pushbutton selector. The controls are **R**, **N**, **D**, arrow **UP**, arrow **DOWN**, **MODE** button and a digital display window. Under normal operation press the “**D**” button and the digital display shows the highest forward range attainable for shift selection in use. The digital display window will also indicate codes for abnormal conditions, and can even be a useful troubleshooting aid. When the ignition is turned ON, the display should be visible. This display indicates the presence of neutral start command. If the display indication is not visible, there is no power to the selector and the transmission will not allow the engine to start. This is an indicator of electrical problems with the engine batteries, ECU on shift selector keypad. The window displays gear selection, various transmission modes, oil level and transmission fault codes.



**Keypad Functions:**

- Select the **REVERSE** gear by pressing “R”.
- Select **NEUTRAL** by pressing “N”. The area around the “N” button has a raised ridge so the driver can orient his hand to the push buttons by touch, without looking at the display.
- Select **DRIVE** range by pressing “D”. The highest forward gear appears in the display and the transmission will shift to first gear though 6 is displayed.
- The **UPSHIFT** and **DOWNSHIFT** arrow buttons are used to select a higher (if not in “D”) or lower (if not in “1”) forward range. These buttons are not functional in **NEUTRAL** or **REVERSE**. One press changes the gear range selected by one. If the button is held continuously, the selected range will continue to change up or down until the button is released or until the highest/lowest possible range of gears is selected.
- The **MODE** button enables a secondary shift point to be selected. This is commonly referred to as “Economy.” It is further used by the service technician to access diagnostic codes when troubleshooting. The diagnostic circuitry must be enabled to display.
- When the Auxiliary Braking device (Jacob or Exhaust brake) is used, the display changes to a default reading of 2 or 3. This default is pre-selected at the factory and can only be reprogrammed by an authorized Allison Service Center. The transmission is not in second or third gear. This is only a reference for the transmission downshift points to optimize the engine braking effect.
- Engine temperature may rise when ascending long grades using full throttle. Towing a load will increase the demand on the engine. If this occurs manually shift the transmission down to the next lower gear and use less throttle. The engine will use less fuel and RPM should increase.

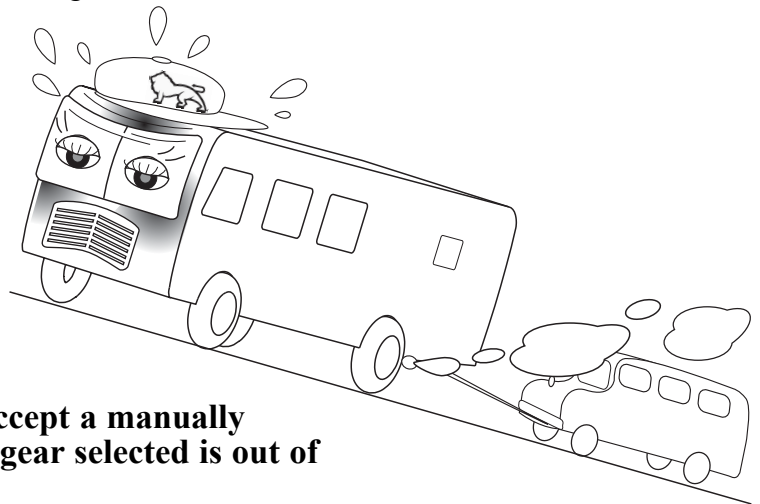

020168d



**NOTE: The transmission will not accept a manually selected gear change to occur if the gear selected is out of the specified operating range.**



**NOTE: The transmission will not shift into gear if the engine RPM is at or above 900. The display will flash 6 indicating the engine RPM is excessive. Select N and lower the engine RPM.**

## **Transmission - Check Light**

The electronic control system of the transmission is programmed to inform the operator of a problem with the transmission system and reacts automatically to protect the operator, motorhome and transmission. When the Electronic Control Unit (ECU) detects a **DO NOT SHIFT** (DNS) condition the ECU restricts shifting, turns on the **CHECK TRANS** light in the instrument panel and registers a fault code.



**NOTE: For some problems, fault codes may be registered without the ECU activating the CHECK TRANS light. An Allison Transmission authorized service outlet should be consulted whenever there is a transmission related concern. They have the equipment to check diagnostic codes and correct problems which may arise.**

Each time the engine is started the **CHECK TRANS** icon will light, then turn off after a few seconds. This momentary lighting is to indicate that the status light circuit is working properly. If the **CHECK TRANS** light does not illuminate during start up, or if the light remains on after start up, the transmission system should be checked immediately.

Continued illumination of the **CHECK TRANS** light during vehicle operation (other than start up) indicates that the ECU has signaled a diagnostic code. Illumination of the **CHECK TRANS** light is accompanied by a flashing display from the shift selector. The shift selector display will show actual range attained and the transmission will not respond to shift selector requests.

Indications from the shift selector are provided to inform the operator that the transmission is not performing as designed and is operating at reduced capabilities. Before turning the ignition off, the transmission may be operated for a short time in the selected range in order to “limp home” for service assistance. Service should be performed immediately in order to minimize potential damage to the transmission.

When the Check Trans icon illuminates the keypad will not respond to command and the transmission generally will downshift to 4th gear. The torque converter will not "lock-up" and engine speed is automatically reduced. Direction changes (i.e. forward to reverse) will not be allowed. Locate a safe secure place to park the motorhome. If the engine is shut off then restarted after a Check Trans indication, the transmission remains in Neutral until the fault causing the Check Trans light has been corrected.

### **Diagnostic Codes:**

The diagnostic codes are numerical representations of malfunctions in the transmission operations. Each code is a two digit main code and a two digit sub code. The codes, when detected, are logged in the ECU memory. These codes will fall in two classes: active and inactive. Active codes are codes currently effecting the ECU process. Inactive codes are retained but may not effect the ECU process. The diagnostic mode must be entered. A maximum of five codes, **D1** to **D5**, may be listed at one time. The highest priority code will be listed in **D1**. The **MODE** button will enable selection of sequential codes.

### **To Enable Diagnostic Code Selection Display:**

- Stop the motorhome at a safe location.
- Apply the parking brake.
- Simultaneously press the up and down arrows twice to enter the stored codes. The first time the arrows are pressed will indicate the oil level display. Press the Up and Down arrows again.
- The codes will display one digit at a time.
- The mode button is pressed to scroll through the codes.
- Any code obtained should be noted and reported to an Allison Service Center for evaluation and possible repair.
- Inactive codes can be cleared by holding the **MODE** button for approximately three seconds. Some codes are self clearing while others will require service or ignition on/off cycles to clear.

The Allison MH Series requires minimum maintenance. Careful attention to the fluid level and the connections for the electronic and hydraulic circuits is very important.

For easier inspection the transmission should be kept clean. Make periodic checks for loose bolts and leaking fluid lines. Check the condition of the electrical harnesses regularly. Check the engine cooling system occasionally for evidence of transmission fluid which would indicate a faulty oil cooler. Report any abnormal condition to an Allison dealer.

### **Prevent Major Problems:**

Help the WTEC III control system oversee the operation of the transmission. Minor problems can be kept from becoming major problems if an Allison Transmission distributor or dealer is notified when one of these conditions occur:

1. The shifting feels abnormal.
2. The transmission leaks fluid.
3. There are unusual transmission-related sounds (changes in sound caused by normal engine thermostatic fan cycling, while climbing a long grade with a heavy load, have been mistaken for transmission-related sounds).
4. The **CHECK TRANS** light comes on frequently.

---

**Transmission  
- Periodic  
Inspections**

### **The Importance of Proper Fluid Levels:**

The transmission fluid cools, lubricates and transmits hydraulic power. Proper fluid levels must be maintained at all times. If the fluid level is too low, the converter and clutches do not receive an adequate supply of fluid. If the fluid level is too high, the fluid can aerate. Aerated fluid can cause the transmission to shift erratically or overheat.

The MH Series oil level sensor (OLS) allows the operator to obtain an indication of sensor fluid level from the keypad shift selector. Frequently check for the presence of oil level diagnostics in the transmission. If the OLS has not been detected, troubleshooting of the OLS circuit is required. This will have to be performed by an Allison Service Center. After the OLS circuit is repaired, ensure that reset of the “autodetect” or manual selection of the OLS function by using a Pro-Link transmission diagnostic center.

### **Fluid Level Check with the Keypad:**

- Park the motorhome on a level surface and place the transmission in “N”. Set the parking brake.
- The transmission should be at normal operating temperature.
- The motorhome should be stationary for approximately two minutes to ensure fluid is stabilized.
- Simultaneously, press the **UP** and **DOWN** arrow buttons one time.
- The fluid level will display in the digital display window. The display indicates one character at a time. The “**o,L**” represents oil level check mode. This is followed by fluid level indication readings. The “**o,K**” indicates a correct fluid level. Reading between the OLS and the dipstick may not agree because the OLS compensates for fluid temperatures.

Abnormal indications of the OLS are:

“**Lo**” = Low fluid level.

“**HI**” = High fluid level.

“**oL**” = Invalid information and system problems.

All indications will be followed by numeric values. The “**Lo**” and “**HI**” followed by the numeric value represents the quarts of fluid required for the system. The invalid code numbers represent specific symptoms.

**Common Oil Level Fault Codes:**

- 0,5 settling time too short.
- 5,0 speed RPM too low.
- 5,9 speed RPM too high.
- 7,0 sump temperature too low.
- 7,9 sump temperature too high.
- 9,5 OLS FAILURE.



**NOTE: Exit the fluid level display by pressing any range button on the keypad.**



**NOTE: To correctly check the transmission fluid level using the dipstick, the transmission fluid must be at operating temperature. The oil level sensor method of checking the fluid level compensates for transmission fluid temperature between 60° C - 104° C (140° F - 220° F). Any temperature below 60° C (140° F), or above 104° C (220° F), will result in an Invalid for display condition.**

Any fluid meeting *Dexron-III*<sup>®</sup> specifications are acceptable for use in the transmission. Transmission performance, reliability and durability are important influences in the type of fluids used. Change the transmissions internal filters after the first 8,000 km (5,000 miles of operation). The dipstick/oil fill is located between the engine and transmission underneath the engine access door in the bedroom. Change the transmission fluid and internal filters every 40,000 km (25,000 miles) or 18 months thereafter, whichever occurs first.

**TRANSMISSION  
LUBRICATING  
FLUID**

**Fluid and Internal Filters Change Interval Recommendations:**

The fluid and internal filters may require changing earlier depending on the severity of operating conditions. The fluid must also be changed whenever there is evidence of dirt or high temperature operation as indicated by discoloration, strong odor or fluid analysis. Local conditions, severity of operation or duty cycle will dictate more or less frequent service intervals. Consult the manufacturer's manual.

**Transmission  
Fluid Level -  
Cold Check**

**Cold Check - Manual Check Procedures:**

The concept of a cold check is to determine adequate fluid level for safe operating until hot check can be performed.



Transmission Oil Level Dipstick.

vault.tiff

**To Check the Fluid When Cold:**

- Park the motorhome on a level surface. Set the parking brake.
- With the engine operated at a low idle. Put the transmission in **N** (Neutral).
- Chock the wheels to prevent the motorhome from moving.
- Allow the engine to run at idle (500-800 rpm) for one minute.
- Apply the service brakes and shift to **D** (Drive), then to **N** (Neutral) and next to **R** (Reverse) to fill the system. Finally shift to **N** (Neutral) and release the service brakes. Allow the engine to continue to run at idle (500-800 RPM).
- Remove the dipstick and wipe clean. Reinsert the dipstick fully into the tube and remove to check fluid level. Repeat this to verify the reading if needed.
- Safe operating level is anywhere within the **COLD CHECK** band on the dipstick. The fluid level is sufficient enough to operate until a **HOT CHECK** can be performed.
- If the level is not within this band, add or drain the fluid as necessary to put the level to the middle of the **COLD CHECK** band.
- Perform the **HOT CHECK** at the first opportunity after reaching normal operating temperatures (160° - 200° F/71° - 93° C).



**CAUTION: Low or high fluid level can cause overheating and irregular shift patterns. These conditions can damage the transmission if not corrected.**

## Transmission Fluid Level - Hot Check

- The fluid level rises as the temperature increases. The fluid must be hot to ensure an accurate check.
- Be sure the fluid has reached normal operating temperature (160° - 200° F/71° - 93° C). If a transmission temperature gauge is not present, check the fluid level when the engine water temperature gauge has stabilized and the transmission has been operated under the load for at least one hour.
- Park the motorhome on a level surface and shift to N (Neutral). Apply the parking brake and allow the engine to idle (500 to 800 RPM).
- After wiping the dipstick clean, check the fluid level. Safe operating level is anywhere within the **HOT RUN** band on the dipstick.
- The width of the **HOT RUN** band is approximately one quart of fluid at normal temperature range.
- If the level is not within this band, add or drain the fluid as necessary to put the level within the **HOT RUN** band.
- Be sure that the fluid level checks are consistent. Check the level more than once. If the readings are not consistent check to be sure that the transmission breather is clean and not clogged. If the readings are still not consistent, contact the nearest Allison distributor or dealer.

Low sulphur #2 diesel fuel or #1 and #2 commercial winter blend diesel fuels are the most common commercially available and recommended for use. The Cummins Engine Company Inc. recommends the use ASTM #2D fuel. The use of #2 diesel fuel will result in optimum engine performance.

## FUEL REQUIREMENTS



**WARNING: Do not mix gasohol with diesel fuel. This mixture can cause an explosion.**



**NOTE: Due to the precise tolerances of diesel injection systems, it is extremely important that fuel be kept clean and free of dirt or water. Dirt or water in the system can cause severe damage to both the fuel pump and the fuel injector. Fuel additives for lubricity are not recommended. There are numerous diesel fuel additives to help remove moisture from fuel, prevent microbe growth and to prevent freeze-up during cold weather. Any fuel additives product should show supporting data for performance and benefits. Engine failures caused by incorrect fuel are not covered under warranty.**

## FUEL TANK

The diesel fuel tank is made of a 12 gauge steel. The total capacity of the tank is 88.5 gallons with approximately 80 gallons usable. The engine pickup tube is cut at a 45° angle to allow optimum flow to the engine.



**NOTE: If the motorhome has been stored for any length of time, check the vent for blockage. It is not uncommon for insects to plug the vent tube. If the tank appears to be pressurized the vent tube may be blocked. To inspect the vent tube check on the roadside of the fuel tank, near the bottom. Always store the motorhome with a full fuel tank.**

### Routine Maintenance Recommendations:

1. Change the fuel filter at every oil change interval.
2. Change the fuel-water separator filter every 12-18 months or every 25,000 miles.

## FUEL/WATER SEPARATOR

The fuel filters are located in the rear engine service compartment on the right side of the motorhome. The primary and secondary fuel filters have drains located at the bottom of the filters. The primary filter has a clear sediment bowl located at the bottom of the filter. Water (by weight) is heavier than fuel and will collect in the sediment bowl. Water can accumulate in the fuel from condensation in the fuel tank or contamination upon refueling.

The appearance of water in the sediment bowl is easily identified by the inability of water to mix with the fuel forming small pools. The water should be drained at the first opportunity. If water passes through the filters it can cause engine misfire and damage fuel injectors.

### To Drain the Filters:

- Shut off the engine.
- Turn the valves counterclockwise approximately 1½ to 2 turns until draining occurs.
- Drain the fuel/water separators of water and sediment until clear fuel is visible.
- Turn the valve clockwise to close the drain valve.
- Depending on the amount of contamination it may be necessary to replace the filters at the first opportunity.

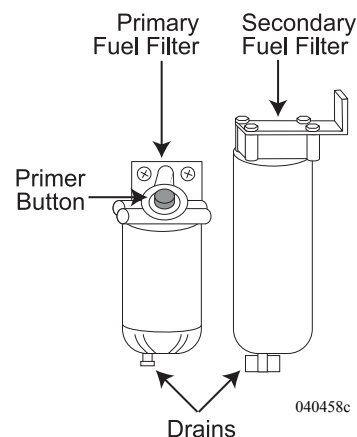

The head of the primary filter has a primer button. Use the button to prime the fuel system when the filters are changed or if the motorhome has run out of fuel. After priming, in the event the engine ran out of fuel, the lift pump on the fuel pump will run for approximately one minute with the ignition on. The ignition may need to be turned on and off several times before attempting a start. If unable to restart, contact the nearest **Cummins Center** or phone **1-800-343-7357** for Cummins Customer Assistance Center.



**FUEL LINES  
& HOSES**

Make a visual check for fuel leaks at all engine-mounted fuel lines and connections and at the fuel tank pick-up and return lines. Leaks in this area may best be detected by checking for accumulation of fuel under the tank. Engine performance and auxiliary equipment is dependent upon the ability of flexible hoses to transfer lubricating oil, air, coolant and fuel oil. Diligent maintenance of hoses is an important step in ensuring efficient, economical and safe operation of engine and related equipment.



**INSPECTION:** Check hoses daily as part of the pre-start-up inspection. Examine hoses for leaks. Check all fittings, clamps and ties carefully. Make sure that the hoses are not touching shafts, couplings and heated surfaces, including exhaust manifolds, sharp edges or other obvious hazardous areas. Since all machinery vibrates and moves to a certain extent, clamps and ties can fatigue with age. To ensure continued proper support, inspect fasteners frequently and tighten or replace them as necessary.

Engine oil levels above the dipstick full mark, or a decrease in lube oil consumption, may indicate internal fuel leaks into the crankcase. Check oil level frequently for fuel contamination.

On a walk around and pre-check of the motorhome, look for oil leaks under the coach and around hose fittings. If a hose connection appears to be leaking, clean the filter and the surrounding area. If the seepage continues, have the problem corrected to prevent an untimely failure.

**HYDRAULIC  
SYSTEMS**

The power steering reservoir is located in the engine service center. The system is filled with *Dexron III*<sup>®</sup>. Keep the reservoir level between the **MIN** and the **MAX** marks.

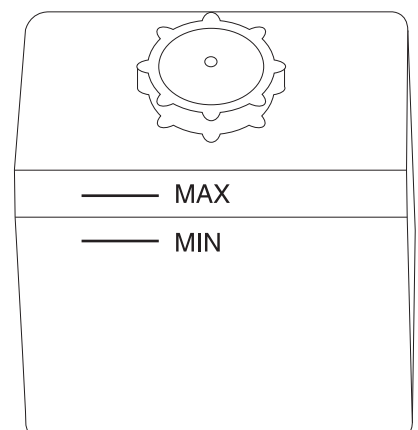

**CAUTION:** If ambient temperatures approach 0° F, Pennzoil Arctic Blue hydraulic fluid, or equivalent hydraulic fluid, should be used. Using incorrect hydraulic system fluid weights in cold or arctic temperatures will raise the hydraulic system operating pressure and may damage system components.

**Hydraulic Reservoir**

Power Steering Reservoir.eps

## STEERING GEAR

Maintain the grease pack behind the output shaft dirt and water seal as a general maintenance procedure at least semi-annually or every 30,000 miles. The grease fitting is provided in the housing trunnion. Use NLGI grade 2 or 3 multipurpose chassis lube and use only a hand operated grease gun on the fitting. Add grease until it begins to extrude past the sector shaft dirt and water seal.

Power steering is provided by using hydraulic pressure to assist rotating the output shaft of the steering gear. Located at the end of the input shaft of the steering gear is poppet valve and worm drive. The poppet valve directs the hydraulic fluid pressure to a type of spool. The worm drive threads in the center of the spool. When in the center position, pressurized hydraulic fluid bypasses the spool. When a turn is made, the poppet valve shifts to one direction or the other, directing the hydraulic pressure to one side of the spool depending on turning direction. The hydraulic fluid is then cooled before returning to the reservoir. Inspect for signs of leakage when performing fluid level checks. Changing the hydraulic filter at regular intervals will help ensure trouble free operation.

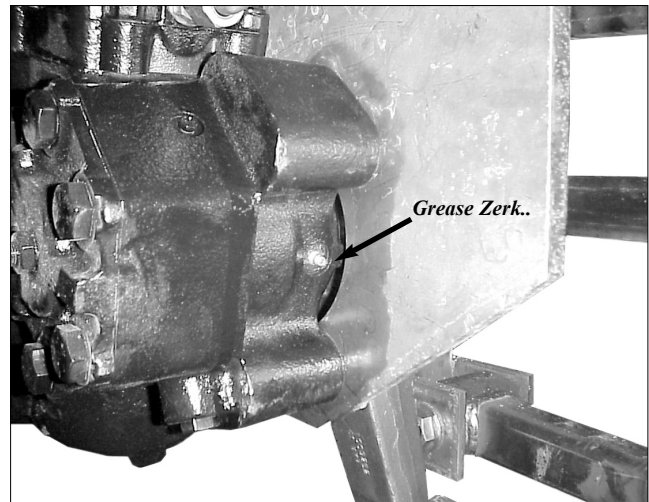

Steering Gear.

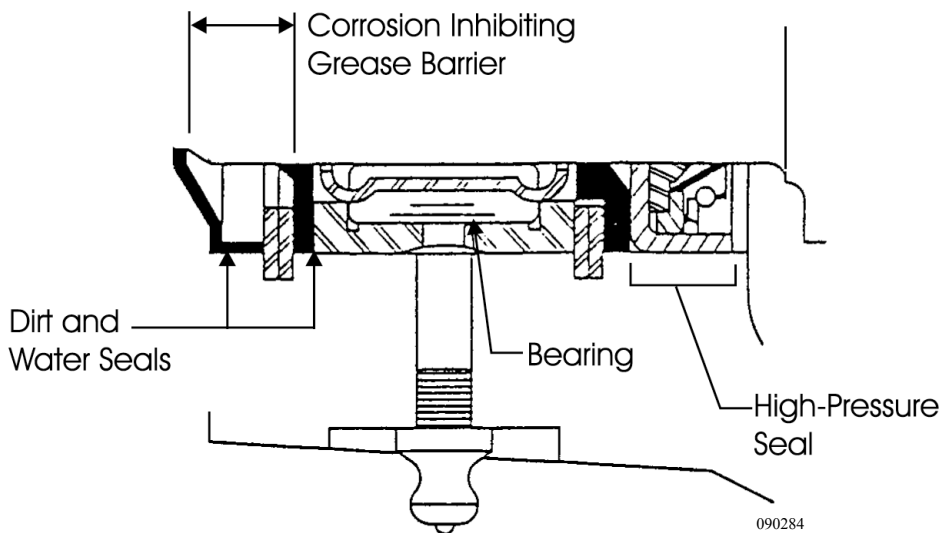

The air filter minder is a precision overflow restriction gauge designed to take the guesswork out of air cleaner replacement.

The air filter minder is located in the engine rear compartment. Its operation is simple and virtually foolproof. As dirt captured by filter cartridge slowly builds up the system pressure drop increases and is indicated by the filter minder on an easy to read scale. The indicator locks up at the point of maximum restriction so readings can be taken with or without the engine running.

When the desired change-out point is reached, the air filter should be replaced and the service indicator is easily reset by pushing the button at the bottom of the minder.

## AIR FILTER MINDER



air minder.tif

The air filter is located on the curbside of the engine. Access the filter from underneath the motorhome. The entire canister is replaced as an assembly and is not serviceable.

## AIR FILTER - Changing

- Remove the air intake hose located on top of the filter canister.
- Remove discharge hose to engine intake piping.
- Remove fasteners securing filter to mounting bracket and discard filter canister.
- Install new filter canister with fasteners. Secure intake and discharge hoses to filter canister.



**WARNING: DO NOT start the engine with the air filter removed or attempt to remove the filter while the engine is running. Severe engine damage or personal injury may result.**

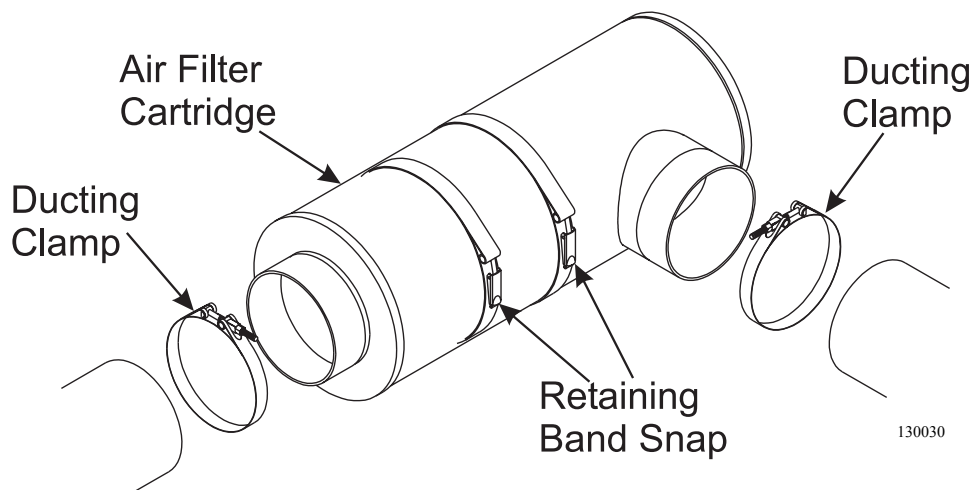

## DRIVE AXLE LUBRICANT

### Proper Drive Axle Lubricant Level:

- Regular **inspection** of the drive axle lube levels is an essential maintenance procedure.
- The lubricant should be level with bottom of the hole.
- Important: The lube level close enough to the hole to be seen or touched is not sufficient. The lube must be level with the hole.
- The differential is filled with multi-viscosity 85-140 weight petroleum-based gear oil.



**NOTE: When checking the lube level also check the housing breathers. Clean the breathers if dirty or replace them if damaged.**

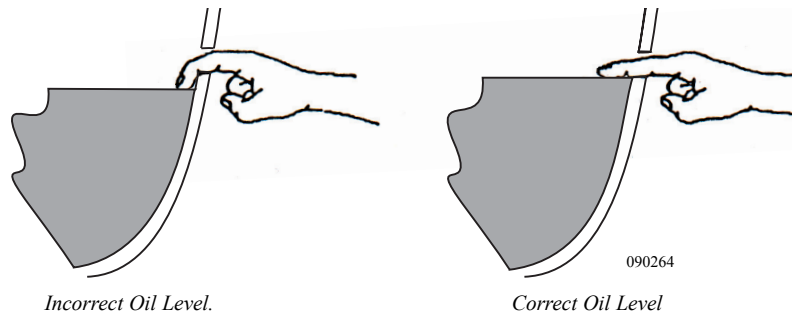

## DRIVE SHAFT

The drive shaft transfers the power produced by the engine to the drive axle. A worn or out of balance driveline causes chassis vibration that generally increases in intensity with road speed.

### Greasing the Drive Shaft Universal Joints:

1. Check the drive shaft for looseness. If loose or worn, repair the drive shaft as necessary.
2. Apply the specified grease at the grease fitting on the U-joint. Apply new grease until new grease purges from all the seals.
3. If new grease does not purge at the seals, loosen the bearing cap bolts and re-grease until all four caps purge. If new grease still does not purge, disassemble and clean or replace the U-joint.

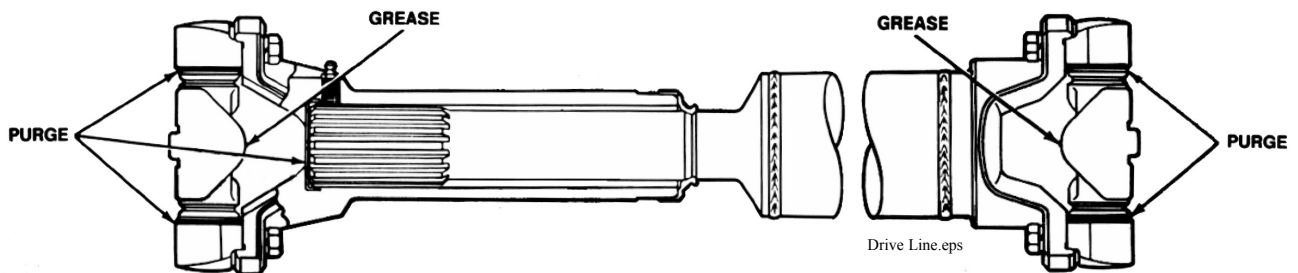

### Greasing the Drive Shaft Slip Yoke and Splines:

1. Check the drive shaft for looseness. If loose or worn, repair the drive shaft as necessary.
2. With finger, cover the rear air hole so grease flows to the front seal. Apply the specified grease at the grease fitting on the slip yoke. Apply grease until new grease purges and forces finger away from the air hole in the end of the slip yoke. Greasing interval is 10,000 miles or annually.



**WARNING: Rotating shafts can be dangerous. Rotating shafts can snag clothes, skin, hair, hands, etc. causing serious injury or death. Do not work on or near a shaft "with or without a guard" when the engine is running.**

Correct U-joint working angles U-joint phasing, and driveline balance is vital to maintaining a quiet-running drivetrain and long life of drivetrain components (including driveline components).

When in phase, the slip yoke lugs (ears) and tube yoke lugs (ears) are in line. Normally this is the ideal condition and gives the smoothest running shaft. There may be an alignment arrow stamped on the slip yoke and on the tube shaft to assure proper phasing when assembling these components. If there are no alignment marks, they should be added before disassembly of the shaft to assure proper reassembly.

Phasing is relatively simple on a two-joint set, be sure that the slip yoke lugs and the tube yoke lugs are in line. The U-Joint working angle is the angle formed by the intersection of the driveshaft centerline and the extended centerline of the shaft of any component to which the U-joint connects. Because the double oscillating motion of a U-joint that connects angled shafts causes a fluctuating speed difference between the shafts, the effect created by the U-joint at one end of the shaft must cancel the effect created by the U-joint at the other end. This is done by making U-joint working angles at both ends of the driveshaft approximately equal, with the U-joints in phase. If the yoke lugs at both ends of the shaft are lying in the same plane (a plane which bisects the shaft lengthwise), the U-joints will be in phase.

Any condition which allows excessive movement of a driveshaft will cause driveline imbalance: loose end yoke nuts, loose U-joint bearing cap retaining capscrews, worn U-joint trunnions, bearings and worn slip-joint splines. Among the most common causes of U-joint and slip joint damage is lack of lubrication.

To keep the motorhome operating smoothly and economically, the driveline must be carefully checked and lubricated at regular intervals.

### ***U-Joint Angles, Phasing & Driveline Balance***

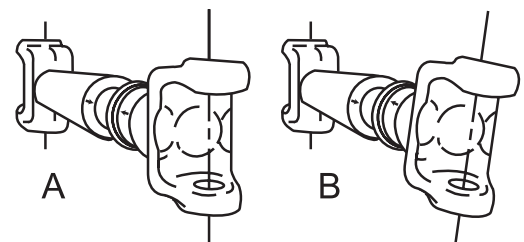

A. In Phase

B. Out of Phase

090337

## LUBRICATION CHART

### Front of Coach

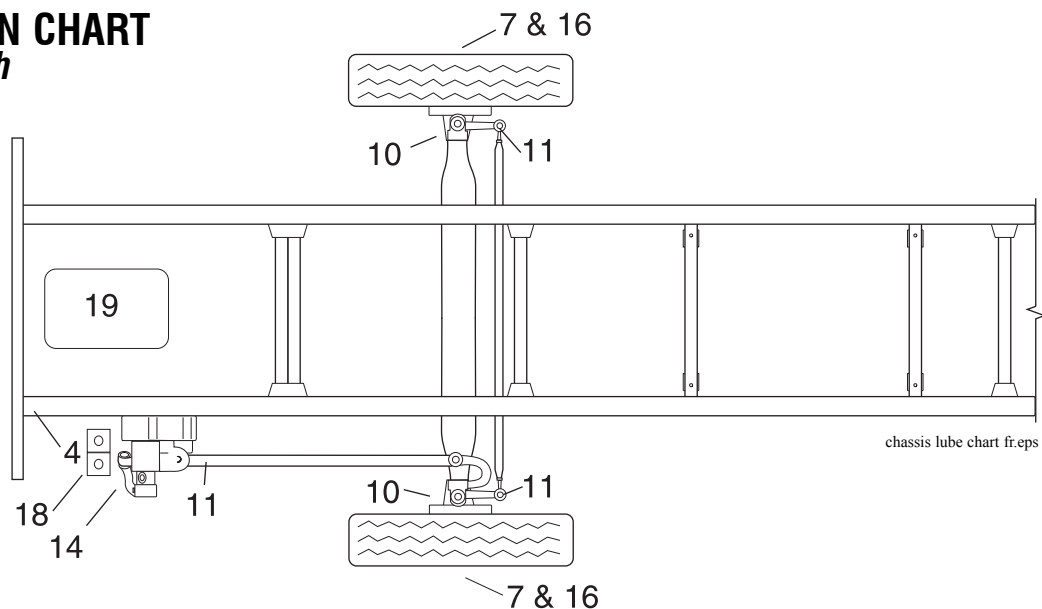

Service must be performed every twelve (12) months regardless of actual mileage, to protect seals, bearings and gaskets from drying out and failing. The motorhome must be started and driven for at least 20 miles bimonthly.

Component	Action	When	Code - Refer To Chart
1. Engine Oil	Keep To Full Mark	Check Daily	EO
2. Engine Oil Filter	Replace	At Oil Change	OP
3. Transmission	Keep To Full Mark	Refer O & E Manual	TF
4. Steering Shaft	3 Fittings	30,000 or Annually	CL-4
5. Drive Shaft U-Joints	2 Fittings	10,000 or Annually	CL
6. Drive Shaft Slip Joint	1 Fitting	10,000 or Annually	CL
7. Steering Axle Hubs	Check Oil level line	1,000	GO
8. Battery Terminals	Apply Coating	10,000 or Annually	P
9. Rear Axle Differential	Replace	30,000 or Annually	MP
10. King Pins & Knuckles	2 Fitting Each End	5,000 or 6 months	CL
11. Drag Link/Tie Rod	4 Fittings	5,000 or 6 months	CL
12. Power Steering Reservoir	Keep To Full	6,000 or 3 months	TF
13. Air Minder	Inspect	Monthly	--
14. Steering Gear Box	1 Fitting	30,000 or Annually	CL
15. Engine Coolant	Replace	Every 2 Years	AF
16. Steering Axle Hubs	Change	30,000 or Annually	GO
17. Engine Fuel Filters	Change	15,000 or 6 months	FF
18. Master Cylinder	Keep to Full	6 months	BF
19. Generator Set	Hours	Refer O & E manual	OP
20. RVA Reservoir	Fill	As Required	TF
21. Air Dryer Filter (Optional)	Replace	1 Year	--

It is important to remember the generator lubrication interval is based on hours of usage. Consult the O & E manual for the generator service interval.

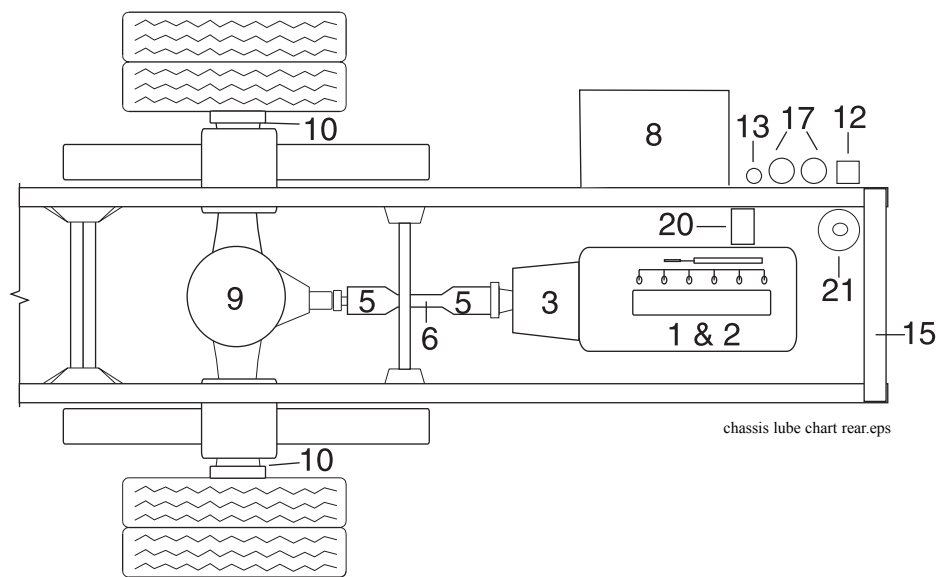
**Rear of Coach****Lubrication Code Chart:**

- CL-4 U-Joints located inside coach under steering cover.
- EO Engine oil as recommended by engine manufacturer.
- OP Refer to operators manual.
- 60-M Multi-viscosity 85-140 petroleum-based gear oil.
- GO EP-SAE 90 gear oil.
- CL Chassis lubricant should be a high quality non corrosive multipurpose lithium soap pressure gun lubricant that is water resistant and designed to withstand extremely high operating temperatures.
- TF Transmission fluid. Use *Dexron III*<sup>®</sup> transmission fluid only.
- P Petroleum jelly, or a commercial battery terminal corrosion inhibitor.
- AF Consult Cummins Owners manual for antifreeze type.
- BF Dot-3 Brake fluid.
- FF Fuel Filter.

## PARTS - COMMON SOLENOIDS & SENDERS

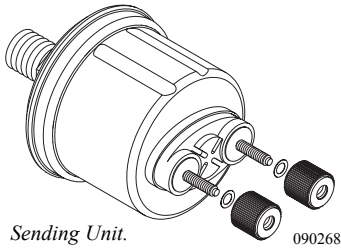

Sending Unit.

### Oil pressure Sending Unit:

- One post is used for the oil pressure gauge and one post is for the warning light.
- Type- VDO 360 0238NDO 0-100 Ohm

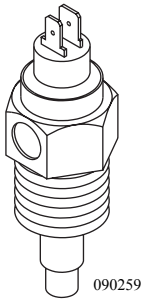

Water Temperature Sender.

### Water Temperature Sending Unit:

- One post is used for the water temperature gauge and one post is used for the warning light.
- Type- VDO 323 0998

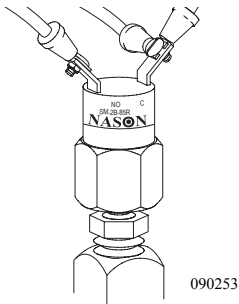

Low Air Switch.

### Low Air Switch:

- 1/8-27 NPT thread.
- Normally closed until approximately 65 psi.
- Located behind dash panel.
- Type- Masson sm-2B-85R, MP# 16616389

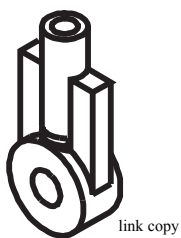

### Link Assembly:

- Located on ends of connecting rod between axles and ride height valve.
- Secures connecting rod with hose clamp.
- Type Hadley Products HPB450-3.
- MP# 2057.

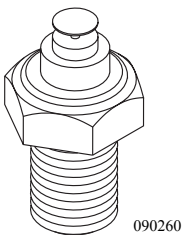

### Transmission Sending Unit:

- Located on the bottom of the tailshaft housing, between hoses.
- Type- VDO 323 0868



**CHART - FILTERS & BELTS**

<b>FILTER &amp; BELT</b>	<b>MANUFACTURER</b>	<b>NUMBER</b>
Coolant Filter	Fleetguard	WF 2071
Oil Filter	Fleetguard	LF 3000
Fuel Filter Primary	Raycor	R 90T
Fuel Filter (Secondary)	Fleetguard	FS 1022
Alternator Belt	Cummins	3911581
A/C Belt	Dayco	17475
Air Filter	Confil Farr	099842-009
Air Dryer Filter	Haldex	DQ 6032 / DA33120
Transmission Filter	--	Allison - 29526889
A/C Filter Drier	Parker	085041-01



**NOTE: Filter and belt numbers were correct at the time of printing. Verify the numbers at time of removal. The manufacturer will not be responsible for incorrect filter or belt usage. Please refer to the engine manufacturer's operating instructions for specific maintenance information.**

## CHART - SPECIFICATIONS

<b>Weights</b>	<b>Unit 3996</b>	<b>Unit 3756</b>
Gross Vehicle Weight Rating	29,500 lbs.	29,500 lbs.
Gross Combined Weight Rating	34,500 lbs.	34,500 lbs.
Front Gross Axle Weight Rating	10,500 lbs.	10,500 lbs.
Rear Gross Axle Weight Rating	19,000 lbs.	19,000 lbs.

<b>Measurements</b>	<b>Unit 3996</b>	<b>Unit 3756</b>
Wheelbase	262 1/4"	*TBA
Overall Length	40' 1"	*TBA
Overall Height	11' 8"	*TBA
Interior Height	77 1/8"	*TBA
Interior Width	97 1/2"	*TBA
Exterior Width (100.5" Floor)	101 3/4"	*TBA

*\*Not available at the time of print.*



**NOTE:** These charts reflect product specifications available at the time of printing. Therefore any floor plans introduced thereafter may not be reflected in the chart. All other information contained throughout the manual will still apply.

<b>Engine Specifications</b>	<b>ISC 350</b>
Cubic Inch Displacement	8.3 Liter 508 CI
Engine HP	350 @ 2,000 RPM
Engine Torque	1050 ft lbs. @ 1,400 RPM
Rear Axle Ratio	4:63
Alternator Size	145 Amp

<b>Chassis Liquid Capacities</b>	<b>ISC 350</b>
Engine Oil	22 Qts
Transmission Oil (initial amount)	22 Qts (MH 3000)
Transmission Oil (with service)	19 w/filter
Radiator Coolant (initial amount)	11.5 Gallons
A/C Refrigerant (initial amount)	4.0 lbs of 134 A
Rear End Capacity	16 Qts approx.

<b>Tank Capacities</b>	<b>Unit 3996</b>	<b>Unit 3756</b>
Water Heater	6 Gallon**	6 Gallon**
Grey Holding Tank	55 Gallon	55 Gallon
Black Holding Tank	55 Gallon	55 Gallon
Fresh Water Tank	95 Gallon	95 Gallon
LP-Gas Tank*	41 Gallon	41 Gallon
Fuel Tank	88 Gallon	88 Gallon

\*Actual filled LP-Gas Tank Capacity is 80% of listing due to safety shut-off required on tank.  
 \*\*10 Gallon optional.



**NOTE: These charts reflect product specifications available at the time of printing. Therefore any floor plans introduced thereafter may not be reflected in the chart. All other information contained throughout the manual will still apply.**

## METRIC/U.S. CONVERSION CHART

U.S. Customary to Metric			Metric to U.S. Customary			
Measurement	Multiplied By	Equals/Measurement	Multiplied By	Equals		
<b>Length</b>						
inches (in)	25.4	millimeters (mm)	0.03937		inches (in)	
inches (in)	2.54	centimeters (cm)	0.3937		inches (in)	
feet (ft)	0.3048	meters (m)	3.281		feet (ft)	
yards (yd)	0.9144	meters (m)	1.094		yards (yd)	
miles (mi)	1.609	kilometers (km)	0.6215		miles (mi)	
<b>Area</b>						
square inches (in <sup>2</sup> )	645.16	square millimeters (m <sup>2</sup> )	0.00155		square inches (in <sup>2</sup> )	
square inches (in <sup>2</sup> )	6.452	square centimeters (cm <sup>2</sup> )	0.15		square inches (in <sup>2</sup> )	
square feet (ft <sup>2</sup> )	0.0929	square meters (m <sup>2</sup> )	10.764		square feet (ft <sup>2</sup> )	
<b>Volume</b>						
cubic inches (in <sup>3</sup> )	16387.0	cubic millimeters (mm <sup>3</sup> )	0.000061		cubic inches (in <sup>3</sup> )	
cubic inches (in <sup>3</sup> )	16.387	cubic centimeters (cm <sup>3</sup> )	0.06102		cubic inches (in <sup>3</sup> )	
cubic inches (in <sup>3</sup> )	0.01639	liters (L)	61.024		cubic inches (in <sup>3</sup> )	
fluid ounces (fl oz)	29.54	milliliters (mL)	0.03381		fluid ounces (fl oz)	
pints (pt)	0.47318	liters (L)	2.1134		pints (pt)	
quarts (qt)	0.94635	liters (L)	1.0567		quarts (qt)	
gallons (gal)	3.7854	liters (L)	0.2642		gallons (gal)	
cubic feet (ft <sup>3</sup> )	28.317	liters (L)	0.03531		cubic feet (ft <sup>3</sup> )	
cubic feet (ft <sup>3</sup> )	0.02832	cubic meters (m <sup>3</sup> )	35.315		cubic feet (ft <sup>3</sup> )	
<b>Weight/Force</b>						
ounces (av) (oz)	28.35	grams (g)	0.03527		ounces (av) (oz)	
pounds (av) (lb)	0.454	kilograms (kg)	2.205		pounds (av) (lb)	
U.S. tons (t)	907.18	kilograms (kg)	0.001102		U.S. tons (t)	
U.S. tons (t)	0.90718	metric tons (t)	1.1023		U.S. tons (t)	
<b>Torque/Work Force</b>						
inch-pounds (lbf.in)	11.298	Newton-centimeters (N.cm)	0.08851		inch-pounds (lbf.in)	
foot-pounds (lbf.ft)	1.3558	Newton-meters (N.m)	0.7376		foot-pounds (lbf.ft)	
<b>Pressure/Vacuum</b>						
inches of mercury (inHg)	3.37685	kiloPascals (kPa)	0.29613		inches of mercury (inHg)	
pounds per square inch (psi)	6.895	kiloPascals (kPa)	0.14503		pounds per square inch (psi)	
Measurement	Subtract	Divide By	Equals/Measurement	Multiply By	Add	Equals
<b>Temperature</b>						
degrees Fahrenheit (°F)	32	1.8	degrees Celsius (°C)	1.8	32	degrees Fahrenheit (°F)





**MAINTENANCE RECORD**

Date	Odometer Reading	Serviced By	Maintenance Performed

## MAINTENANCE RECORD

Date	Odometer Reading	Serviced By	Maintenance Performed





## **TECHNICAL PUBLICATIONS**

**Manager** Vance Buell  
Editing Technical Publications

## **\* OREGON OPERATIONS**

### **Technical Writers**

Robert Buckholtz  
William Birch

### **Creative**

**Layout Design** Kelly Stroble, Rena Koffler

**Cover Design** Kelly Stroble

**Technical Illustrator** Judie Pressler  
Rena Koffler

### **Printing**

Technaprint

## **INDIANA OPERATIONS**

### **Technical Writer**

Fran Weisenstein

### **Creative**

**Layout Design** Wes Bogan

**Technical Illustrator** Judie Pressler

## **VIDEO PRODUCTIONS**

Dean Mitchell

## **ONLINE**

### **SAFARI**

[www.safarimotorcoaches.com](http://www.safarimotorcoaches.com)

# SAHARA

**WIRING DIAGRAMS  
INDEX**



---

**— A —**

<b>Air Conditioner - Roof</b> .....	131
Operation.....	131
<b>Air Coupler - Universal</b> .....	274
<b>Air Dryer</b> .....	273
Air Dryer Filter.....	273
<b>Air Filter - Changing</b> .....	307
<b>Air Filter Minder</b> .....	307
<b>Air Governor</b> .....	273
<b>Air Storage Tanks</b> .....	274
<b>Air Supply System</b> .....	272
<b>Alignment Specifications</b> .....	279
<b>Alternator</b> .....	265
Alternator Testing Procedure.....	266
Battery Isolator.....	267
Check Out Procedure.....	266
<b>Awnings</b> .....	157
Awning - Automatic Carefree (Opt.).....	161
Awning - Patio.....	158
Awning Care & Maintenance.....	160
Front Door.....	157

**— B —**

<b>Backing Up A Motorhome</b> .....	39
<b>Battery Cut-off Switch</b> .....	212
<b>Battery - Chassis</b> .....	246
Battery Specifications - Chassis.....	247
<b>Battery Disconnect - Chassis</b> .....	245
<b>Battery - How It Works</b> .....	224
Battery Charge Time & Consumption Rate	230
Battery Maintenance.....	226
Battery Specifications - House.....	232
Battery Trays.....	225
Battery Voltage & Current.....	229
Deep Cycle Battery.....	225
Reasons Why Batteries Fail.....	228
Starting Battery.....	224
Testing the Battery.....	226

<b>Brake - Park &amp; Emergency Systems</b> .....	281
<b>Brake Systems</b> .....	281
<b>Brake - Air Over Hydraulic</b> .....	283
Bleeding the System.....	284
<b>Brakes - ABS System (Anti-lock Brakes)</b> ...	281
<b>Brakes - Exhaust Brake System</b> .....	281
Exhaust Brake Maintenance.....	282
<b>Brakes - Maintenance &amp; Troubleshooting</b> ..	283
<b>Breaking Camp</b> .....	47

**— C —**

<b>Carbon Monoxide Detector</b> .....	74
Alarm.....	75
Cleaning.....	75
Operation Instructions.....	74
Testing.....	75
<b>Chart - Tank Capacities</b> .....	192
<b>Chart - Tire</b> .....	62
<b>Chart - Lubrication</b> .....	310
<b>Chart - Metric Conversion</b> .....	316
<b>Charts - Filters &amp; Belts</b> .....	313
<b>Charts - Specifications</b> .....	314
<b>Checklist - LP-Gas Emergency Procedures</b> ..	198
<b>Checklist - Pre-trip Preparations</b> .....	35
<b>Checklist - Set-up Procedures</b> .....	41
<b>Checklist - Winter Storage</b> .....	108
<b>Cockpit Blinds</b> .....	165
<b>Cold Weather Use</b> .....	189

“C” Continued on following page.

---

— E —

**“C” Continued...**

<b>Cooktop Range (Opt.)</b> .....	130
Lighting Oven Pilot.....	130
<b>Cooktop Range/Oven</b> .....	127
Burner Grate.....	128
Cleaning & Maintenance.....	129
Lighting Top Burners.....	128
Operation.....	128
Tips.....	129
<b>Coolant</b> .....	293
Coolant - Additive (SCA).....	295
Coolant Hoses.....	295
Coolant System - Thawing.....	296
<b>Customer Relations</b> .....	13

---

— D —

<b>Dash</b> .....	248
Air Conditioner & Heater Controls.....	254
Gauges.....	248
Indicator Lamps.....	250
Parking Brake.....	261
Switches - Dash.....	252
<b>Diagnostic Plug Location</b> .....	264
<b>Dinette Bed Conversion (Opt.)</b> .....	166
<b>Distribution Panel - House</b> .....	220
Circuit Breakers.....	220
Fuses - 12 Volt DC.....	221
<b>Door - Sliding</b> .....	166
<b>Drive Axle Lubricant</b> .....	308
<b>Drive Shaft</b> .....	308
U-Joint Angles, Phasing & Driveline Bal. ....	309
<b>Driving &amp; Safety</b> .....	27
Familiarize Yourself.....	31
Inspections.....	31
Safety Seat Belts.....	31
Tips for Driving.....	32
<b>Dry Camping Tips</b> .....	43

<b>Echo Charger</b> .....	268
<b>Egress Exit Window</b> .....	76
<b>Emergency Procedures - Roadside</b> .....	49
Jump Starting.....	50
Light - Retractable.....	49
Transmission - Rocking Out.....	50
<b>Engine - General Information</b> .....	288
<b>Engine</b> .....	289
<b>Engine Shutdown</b> .....	293
<b>Engine Shutdown - Extended</b> .....	293
<b>Entertainment Systems</b> .....	167
Entertainment Hook-ups - Exterior.....	171
Hook-ups - TV Cable, Computer & Telephone .....	171
Television Antenna.....	168
Television (Front) w/Lock-out Feature.....	168
Video Cassette Recorder (VCR) (Opt.).....	167
Video Selector Box (Opt.).....	171
<b>Entry Door</b> .....	147
Entry Door - Side Entry.....	149
Front Entry.....	147
Latch Adjustment.....	148
Screen Door - Adjusting.....	148
Screen Door - Changing the Glass.....	148
Screen Door - Removing the Screen.....	149
<b>Entry Step</b> .....	145
Maintenance & Lubrication.....	146
Operation.....	145
Tips.....	146
<b>Exterior Care</b> .....	79
Bright Metal.....	82
Care & Maintenance of Aluminum Wheels .....	81
Corrosion.....	79
Drying.....	80
Maintenance - Exterior.....	82
Roof Care & Seal Inspections.....	83
Tire Care.....	81
Washing.....	79
Waxing.....	80

---

**F, G**

---

<b>Fans</b> .....	164
Bathroom Fan.....	165
Exhaust Fan.....	164
Tips.....	164
<b>Fire Extinguisher</b> .....	75
<b>Front Axle (Oil Filled Bearings)</b> .....	285
<b>Fuel Line &amp; Hoses</b> .....	305
<b>Fuel Requirements</b> .....	303
<b>Fuel Tank</b> .....	304
<b>Fuel/Water Separator</b> .....	304
<b>Furnace</b> .....	132
Operation.....	132
Tips.....	133
If Furnace Fails to Light.....	134
<b>Fuses &amp; Circuits - Chassis</b> .....	264
Distribution Panel - Front.....	264
Distribution Panel - Rear.....	265
<b>Generator 120 AC (LP-Gas)</b> .....	215
<b>Generator 120 AC Diesel (Opt.)</b> .....	216
Generator Exercise.....	219
Generator Fuel.....	218
Powering the Equipment.....	218
Pre-start Checks.....	216
Resetting the Circuit Breakers.....	219
Starting the Generator.....	217
Stopping the Generator.....	217
<b>GFCI Breakers &amp; Outlets</b> .....	222
Know When to Say No.....	223
Tools of the Trade.....	223
<b>Glossary of Terms</b> .....	20

---

**H**

---

<b>Hitch</b> .....	37
Using the Rear Receiver.....	37
Tow Harness.....	38
<b>Hydraulic Systems</b> .....	305
Hydraulic Reservoir.....	305

---

**I**

---

<b>Interior Care</b> .....	84
Ceilings.....	96
Countertops.....	100
Day/Night Shades (Bedroom).....	104
Fabric Specifications Chart.....	87
Fabrics.....	84
Floors - Carpet Cleaning.....	94
Floors - Laminate.....	95
Leather.....	92
Mini-blinds.....	103
Mold & Mildew.....	102
Shower - Cleaning.....	96
Ultra-Leather.....	93
Vinyl.....	90
Wall Coverings.....	96
Windows.....	101
Wood Care.....	98
<b>Inverter/Converter</b> .....	233
Battery Charging.....	233
Battery State Indicator.....	235
Charge Cycles.....	236
Circuit Breakers.....	235
Equalize Charge.....	237
Pass-through Relay.....	236
Power Share.....	235
Programming the Inverter.....	237
Remote Panel.....	234
Stand-By Mode.....	235
Temperature Sensitive Charging.....	236

## — J, K, L —

<b>Leveling System - Hydraulic Leveling</b> .....	285
Manual Leveling System.....	286
Manual Retract Valves.....	287
<b>Limited Warranty</b> .....	1
Disclaimer of Consequential & Incidental.....	4
Events Discharging Warrantor.....	4
How to Get Service.....	3
Legal Remedies.....	4
Limitations of Implied Warranties.....	2
What the Warranty Covers.....	2
What the Warranty Does Not Cover.....	3
What We Will Do to Correct Problems.....	2
<b>Limited Warranty - Magnum Chassis</b> .....	5
Disclaimer of Consequential & Incidental.....	7
Events Discharging Warrantor.....	7
How to Get Service.....	6
Legal Remedies.....	7
Limitations of Implied Warranties.....	5
What the Warranty Covers.....	5
What the Warranty Does Not Cover.....	7
What We Will Do to Correct Problems.....	6
<b>LP-Gas Consumption</b> .....	204
<b>LP-Gas Detector</b> .....	72, 196
Alarm.....	73, 197
Care of the Detector.....	197
Cleaning.....	73
Operation.....	196
Testing.....	72, 196
<b>LP-Gas Distribution Lines</b> .....	205
<b>LP-Gas Emergency Procedures - Checklist</b>	198
<b>LP-Gas Fundamentals</b> .....	200
<b>LP-Gas Hose Inspection</b> .....	203
<b>LP-Gas Regulator</b> .....	202
<b>LP-Gas Safety Tips</b> .....	206
<b>LP-Gas System</b> .....	195
<b>LP-Gas Tank</b> .....	199
LP-Gas Tank Filling.....	200
Operation.....	199
<b>LP-Gas Tank Capacity</b> .....	199
<b>Lubrication Chart</b> .....	310

## — M, N, O —

<b>Maintenance Record</b> .....	317
<b>Microwave Oven</b> .....	119
Care & Cleaning.....	127
Convection Cooking.....	125
Microwave Cooking.....	124
Operation.....	122
Tips.....	126
<b>Monitor Panel Measurement</b> .....	177, 198
<b>Oil Recommendations (Engine)</b> .....	290
Oil Recommendation - Cold Weather.....	292
<b>Owner's Record - Insurance</b> .....	19
<b>Owner's Record - Personal Property</b> .....	18
<b>Owner's Record - Serial Numbers</b> .....	17

## — P, Q, R —

<b>Parts - Common Solenoids &amp; Senders</b> .....	312
<b>Radio - Dash</b> .....	172
<b>Rear View System</b> .....	38
<b>Refrigerator</b> .....	113
Alarm.....	118
Cooling Unit Fans (Four Door Models)....	118
Control Panel - Four Door (Opt.).....	116
Control Panel - Two Door.....	115
Doors.....	117
Ice Maker (Opt.).....	117
Operation Specifics.....	114
Refrigerator Controls.....	114
Service.....	118
Storage.....	119
<b>Reporting Safety Defects</b> .....	14



---

— S —

<b>Servive Center</b> .....	192
<b>Service Suggestions</b> .....	15
Be Reasonable With Your Requests.....	15
Inspect the Work Properly.....	16
No Looking Over the Tech. Shoulder.....	16
Prepare a List.....	15
Prepare for the Appointment.....	15
<b>Shifter Panel - Tansmission Shifter</b> .....	263
<b>Shock Absorbers</b> .....	277
<b>Shore Power Hook-Up</b> .....	212
<b>Slide-out Cover</b> .....	163
<b>Slide-out Operation</b> .....	151
Extending Bedroom Slide-out.....	154
Extending Main Room(s).....	152
Manual Override - Bedroom Slide-out.....	156
Retracting Bedroom Slide-out.....	153
Retracting Main Room(s).....	153
Troubleshooting.....	153
<b>Smoke Detector</b> .....	70
How to Test.....	71
Maintenance.....	71
Operation.....	70
Troubleshooting.....	71
<b>Sofa Bed Conversion</b> .....	166
Sofa to Sleeper.....	166
Sleeper to Sofa.....	166
<b>Solar Panel (Opt.)</b> .....	239
<b>Specifications - Dimensions Chart</b> .....	70
<b>Starting Procedure</b> .....	290
<b>Starting Procedure - Cold Weather</b> .....	290
<b>Steering Column</b> .....	262
Tilt & Telescope.....	262
<b>Steering Gear</b> .....	306
<b>Storage - Cold Weather</b> .....	189
<b>Storage - Long Term</b> .....	105
<b>Storage - Short Term</b> .....	104
<b>Storage Removal</b> .....	108
<b>Storage - Under Bed</b> .....	167
<b>Super Slide (Opt.)</b> .....	167
<b>Suspension</b> .....	278

<b>Suspension Air Ride Bags</b> .....	275
Checklist - Air Bag Inspections.....	276
<b>Survey</b> .....	27

— T, U —

<b>Taking Delivery</b> .....	14
Customer Responsibilities.....	15
Dealer Responsibilities.....	14
Safari Responsibilities.....	14
<b>Tank Capacities - Chart</b> .....	192
<b>Tires</b> .....	54
How Much Air Should I Carry in My Tires?...	55
The Importance of Air Pressure.....	54
Tire Pressure Inflation Guideline.....	55
<b>Tire Chart</b> .....	62
In Case of Flat Tire.....	65
Inspecting & Pressure.....	62
Storage of Tires - Long Term.....	65
Tire Rotation.....	64
Tire Vibration.....	64
Tires - Supporting When Leveling.....	64
<b>Toilet</b> .....	187
Cleaning.....	187
Drain Traps & Auto Vents.....	188
Operating Instructions.....	187
Maintenance.....	187
<b>Towing Procedures</b> .....	53
<b>Transfer Switch</b> .....	215
<b>Transmission</b> .....	296
Shift Selector.....	296
Transmission - Check Light.....	298
Transmission - Periodic Inspections.....	299
<b>Transmission Lubricating Fluid</b> .....	301
Transmission Fluid Level - Cold Check.....	302
Transmission Fluid Level - Hot Check... ..	303

— V, W, X, Y, Z —

<b>Views</b> .....	68	<b>Weighing the Motorhome</b> .....	58
Curbside.....	69	<b>Weight Terms</b> .....	56
Front.....	68	Weight Label.....	58
Rear.....	68	<b>Winter Storage - Checklist</b> .....	108
Roadside.....	69	<b>Winterizing - Using Air Pressure</b> .....	191
<b>Wall Thermostat</b> .....	131	<b>Winterizing - Using Nontoxic Antifreeze</b> ....	190
<b>Vendor List</b> .....	24		
<b>Warranty Information File</b> .....	8		
<b>Washer/Dryer (Opt.)</b> .....	140		
Cleaning the Drain Screen.....	141		
Cleaning the Washer/Dryer.....	142		
Operating Instructions.....	140		
Winterizing the Washer/Dryer.....	142		
<b>Washer/Dryer Prepared</b> .....	139		
<b>Waste Water Systems</b> .....	182		
Black Tank Flush.....	185		
Proper Waste Disposal.....	182		
Waste Drain Hose.....	184		
Waste Drains & Sewage Tanks.....	183		
What Not to Put in Waste Holding Tanks..	183		
What to Put in..... - Black Water Tank....	185		
What to Put in..... - Grey Water Tank.....	185		
<b>Water - City Hook-Up</b> .....	178		
<b>Water Heater</b> .....	134		
Before Using the Water Heater.....	135		
Burner Compartment.....	137		
Draining & Storage.....	139		
Operation.....	135		
Pressure - Temperature Relief Valve.....	137		
Tips.....	138		
Troubleshooting.....	139		
Water Heater Bypass System.....	138		
<b>Water Pump</b> .....	179		
Water Pump - Troubleshooting.....	180		
<b>Water System - Disinfecting Fresh Water</b> ..	181		
<b>Water System - Troubleshooting</b> .....	181		
<b>Water Systems - Introduction</b> .....	177		
<b>Water Tank - Fresh Fill</b> .....	178		